



# Cisco NCS 1014 Overview

This chapter provides an overview for the Cisco NCS 1014 chassis, its modules and line cards.

- [Cisco NCS 1014 Chassis Overview](#) , on page 1
- [Cisco NCS 1014 Line Cards](#), on page 4
- [Cisco NCS 1014 Modules](#), on page 11
- [Supported Pluggables](#), on page 24

## Cisco NCS 1014 Chassis Overview

The Cisco NCS 1014 chassis is an advanced multihaul optical platform supporting transponders and line system cards. It is a 2RU chassis that delivers a universal transponder solution which provides excellent performance for metro, long-haul and submarine applications.

Cisco NCS 1014 chassis has slots for the following modules:

- Removable controller
- Removable backup solid state drive (SSD)
- Two replaceable power supply units (PSU)
- Three replaceable fan modules
- Four line cards

The Cisco NCS 1014 chassis supports the following line cards.

**Table 1: Supported Line Cards**

Line Card	Description	Release
<a href="#">2.4T Line Card</a>	2.4T DWDM Transponder Card	Cisco IOS XR Release 7.11.1
<a href="#">NCS 1000 16-Port Colorless Mux/Demux Optical Line Card</a>	16-port Colorless Mux/Demux Optical Line Card, C-band	Cisco IOS XR Release 7.11.1
<a href="#">NCS 1000 16-Port Colorless Mux/Demux Optical Line Card</a>	16-port Colorless Mux/Demux Optical Line Card, L-band	Cisco IOS XR Release 7.11.1
<a href="#">1.2T Line Card</a>	1.2T DWDM Transponder Card	Cisco IOS XR Release 7.11.1

Line Card	Description	Release
<a href="#">2.4TX Line Card</a>	2.4TX DWDM Transponder Card	Cisco IOS XR Release 24.1.1
<a href="#">QXP-K9 Line Card</a>	3.2T DWDM Transponder Card	Cisco IOS XR Release 24.1.1

The Cisco NCS 1014 chassis has two slots for field-replaceable AC and DC PSUs that support up to 2.5 kW per system and 580 W per line card slot.

For more information about the Cisco NCS 1014 chassis, see [Cisco NCS 1014 datasheet](#).

**Note**

- "2.4T" refers to the NCS1K14-2.4T-K9 line card.
- "CCMD-16-C" refers to the NCS1K14-CCMD-16-C C-band optical line card.
- "CCMD-16-L" refers to the NCS1K14-CCMD-16-L optical line card.
- "1.2T" refers to the NCS1K4-1.2T-K9 line card.
- "2.4TX" refers to the NCS1K14-2.4T-X-K9 line card.
- "QXP-K9" refers to the NCS1K4-QXP-K9 line card.

The controller is on the front side. The SSD, PSUs, and the fan modules are on the rear side of the chassis. You can insert the line cards into the four slots as shown in the following figure.

**Figure 1: NCS 1014 Front View**

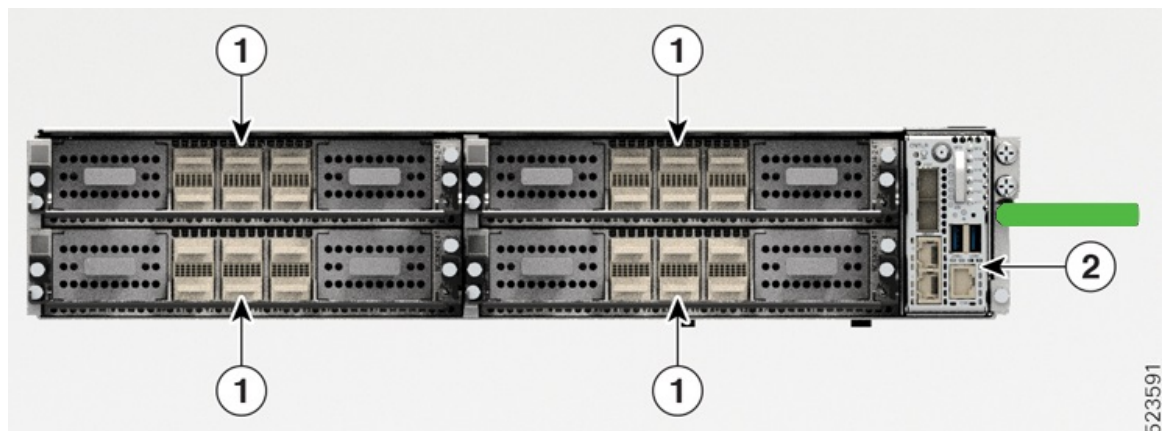

Callout	Modules
1	Line Cards
2	Controller

The following figure shows the PSUs, fan modules, and SSD installed in the chassis.

Figure 2: NCS 1014 Rear View

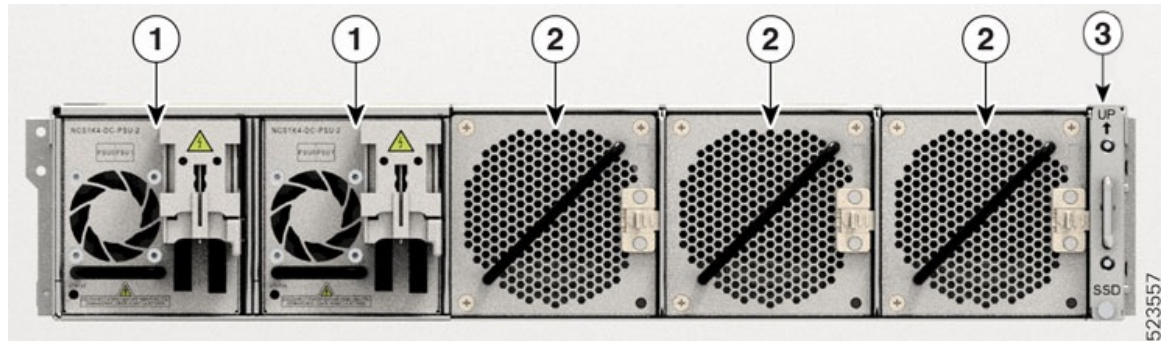

Callout	Modules
1	Power Supply Units (Slots 0 and 1)
2	Fan Modules (Slots 0, 1, and 2)
3	SSD

You must install AC or DC PSUs as the power supply modules. The chassis does not allow mixed PSU configuration.

### Airflow in the Cisco NCS 1014 Chassis

The Cisco NCS 1014 chassis has a front-to-back airflow scheme. The air inlet is at the front side of the chassis and the exhaust is on the rear side. The fan modules cool down the line cards. Ensure that no object obstructs or impedes the airflow as it can lead to reduced airflow in the system, causing components to operate at a higher temperature.

Figure 3: Airflow Through the Cisco NCS 1014 Chassis

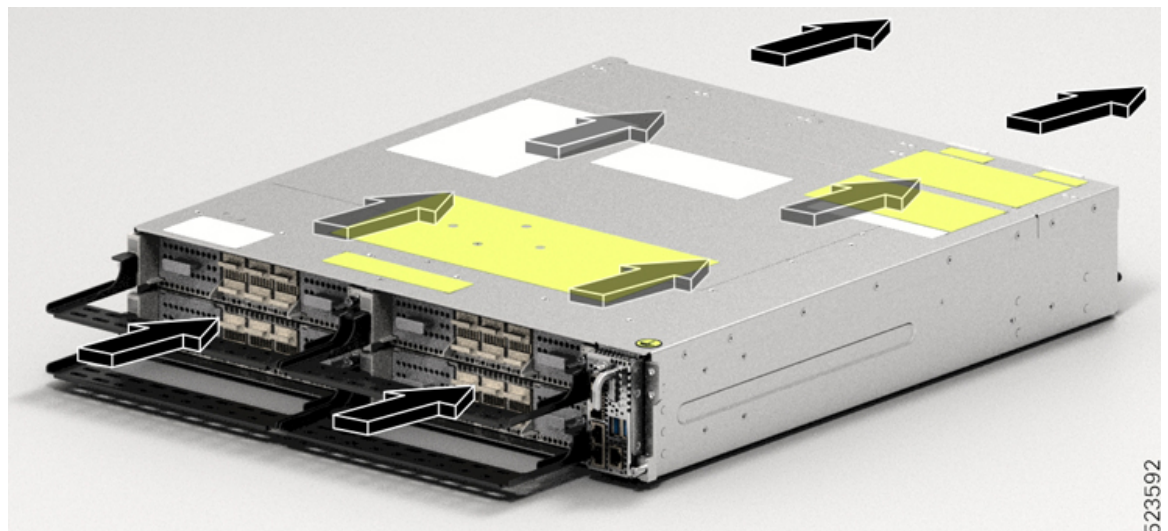

### Class 1M Laser Product Label

The Class 1M Laser Product label is shown in the following figure.

*Figure 4: Class 1M Laser Product Label*



Complies with 21 CFR 1040.10 and 1040.11 except for conformance with IEC 60825-1 Ed. 3., as described in Laser Notice No. 56, dated May 8, 2019.

Conforme à la norme 21 CFR 1040.10 et 1040.11, sauf conformité avec la norme IEC 60825-1 Ed. 3., comme décrit dans l'avis relatif au laser no. 56, daté du 8 Mai 2019.

## Cooling System

The Cisco NCS 1014 cooling system actively regulates the chassis temperature using the three field-replaceable fan trays and the built-in fans within the PSU units. This system implements cooling in two different airflow paths:

- **Line Cards Cooling**

The three fan modules enable cooling for the line cards. The software monitors the chassis temperature and adjusts the fan speed according to the ambient temperature range.

- **Controller Card Cooling**

The internal fans within the two PSUs cool the controller card. If any critical alarms arise due to controller temperature, the software overrides the PSU fan speed.



---

**Note** For normal operating conditions, the software does not control the PSU fans.

---

During the power cycle, each fan runs at maximum rotations per minute. After the chassis boots up, the fans return to their normal speed according to the ambient temperature.

## Cisco NCS 1014 Line Cards

The Cisco NCS 1014 chassis supports the following line cards:

## 2.4T Line Card

The 2.4T line card is a coherent optics Transponder and Muxponder for the Cisco NCS 1014 chassis. It is a single-slot card that supports C-band traffic at trunk ports. This line card delivers 400GE, 100GE, and OTU4 client traffic over two trunk ports operating at speeds ranging from 400G to 1.2T each.



**Note** In Release 7.11.1, the 2.4T line card supports only 400, 600, 800, and 1000G trunk payloads.

In the 2.4T card, the client and trunk ports support the pluggable form factor and data rates as shown in the following table.

**Table 2: NCS1K14-2.4T-K9 Interfaces and Data Rates**

Interfaces	Form Factor	Ports	Data Rates
Client	QSFP-DD56	1, 2, 3, 4, 5, 6	100, 200, 400G
	QSFP-DD112	2, 5, 6	100, 200, 400, 800G
Trunk	Coherent Interface Module 8 (CIM8)	0, 7	1.2T in each port



**Note** In Release 7.11.1, the ports 2, 5, and 6 support only up to 400GE data rates.

For more information about the 2.4T card, see [datasheet](#).

The 2.4T card has two trunk ports and six client ports as shown in the following figure.

**Figure 5: 2.4T Line Card Front View**

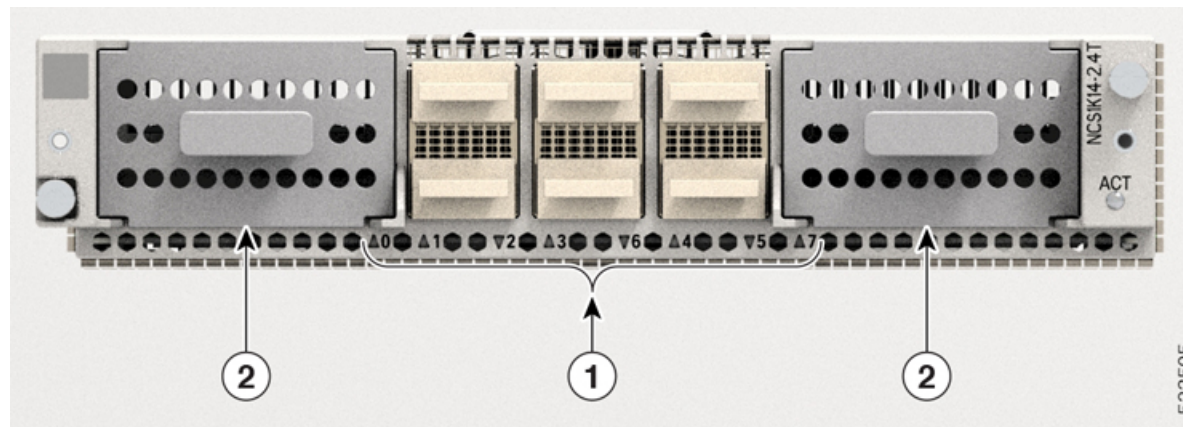

**Table 3: 2.4T Line Card Interfaces**

Callout	Interface
1	Client port

Callout	Interface
2	Trunk port

The following figure shows the mapping between the client and trunk ports.

**Figure 6: 2.4T Card Client and Trunk Mapping**

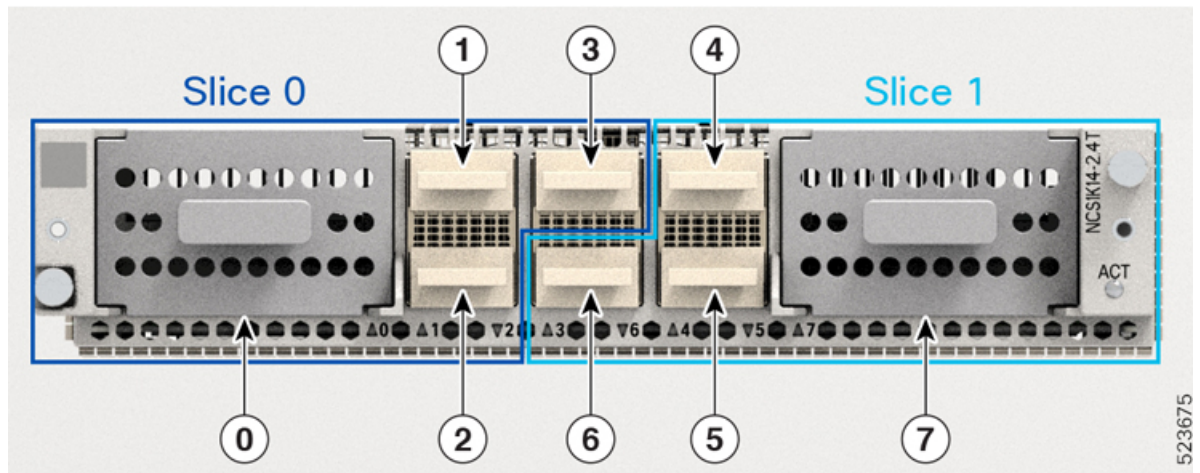

**Table 4: Client-to-Trunk Port Mapping**

Trunk Port	Client Ports
0	1, 2, 3
7	4, 5, 6

## NCS 1000 16-Port Colorless Mux/Demux Optical Line Card

The NCS 1000 16-port Colorless Mux/Demux Optical Line Card is a multiplexing and demultiplexing unit with fixed gain EDFAs on both Add and Drop sections. The optical line card provides colorless functionality on the add/drop ports. It multiplexes any wavelength with the flexible options of baud rate and modulation format to the line side ROADMs or amplifier units for transmission. It transmits and receives signals from optical line terminal (OLT) units.

In the Cisco NCS 1014 chassis, you can install the optical line card in one or more cardslots.

The optical line card has:

- Two line ports to transmit and receive using the same LC connectors.
- 16 ports for add/drop with LC connector-based interfaces

There are two variants of the optical line card:

- **NCS1K14-CCMD-16-C**

The NCS1K14-CCMD-16-C line card is a C-band, 16-port Colorless Direct attach optical line card with EDFA. It can host up to 16 channels. It supports any signal distribution between 191250 and 196200 GHz, for example, the 64 channels grid with 75-GHz spacing.

The following table summarizes the central frequency of the first and the last channel of this specific grid.

**Table 5: C-Band Channel Wavelength Plan**

Channel	Central Frequency (THz)	Wavelength (nm)
1	196.100	1528.77
64	191.375	1566.52

#### • NCS1K14-CCMD-16-L

The NCS1K14-CCMD-16-L line card is an L-band, 16-port Colorless Direct attach optical line card with EDFA. It can host up to 16 channels. It supports any signal distribution between 186025 and 191000 GHz, for example, the 64 channels grid with 75-GHz spacing.

The following table summarizes the central frequency of the first and the last channel of this specific grid.

**Table 6: L-Band Channel Wavelength Plan**

Channel	Central Frequency (THz)	Wavelength (nm)
1	190.850	1570.83
64	186.125	1610.7

**Figure 7: NCS1K14-CCMD-16 Line Card Front View**

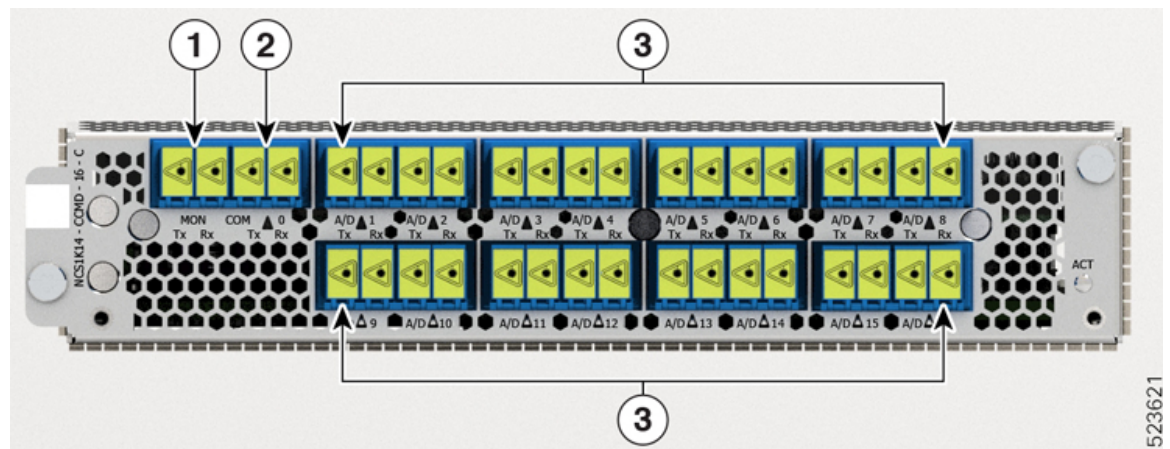

The following table shows the port names and their connector types for both CCDM-16-C and CCMD-16-L cards.

Table 7: Line Card Interface and Connector Assignment

Callout	Connector Label	Connector Type	Port Name
1	MON	LC	MON TX
			MON RX
2	COM	LC	COM TX
			COM RX
3	A/D 1...16	LC	A/D TX [1...16]
			A/D RX [1...16]

## 1.2T Line Card

The 1.2T DWDM line card can provide up to 12 OTU4 or three 400G client ports.

The 1.2T DWDM line card is a transponder that has 12 client ports to deliver 100GE and OTU4 client traffic. This line card has two trunks that operate at any rate between 100G and 600G in 50G increments. It uses Advanced Encryption Standard with a 256-bit key length (AES256)-based Layer-1 encryption to encrypt client-side data for 100GE and OTU4. The NCS1K4-1.2T-K9 line card is a single-slot unit that supports C-band traffic.

Figure 8: 1.2T DWDM Line Card Front View

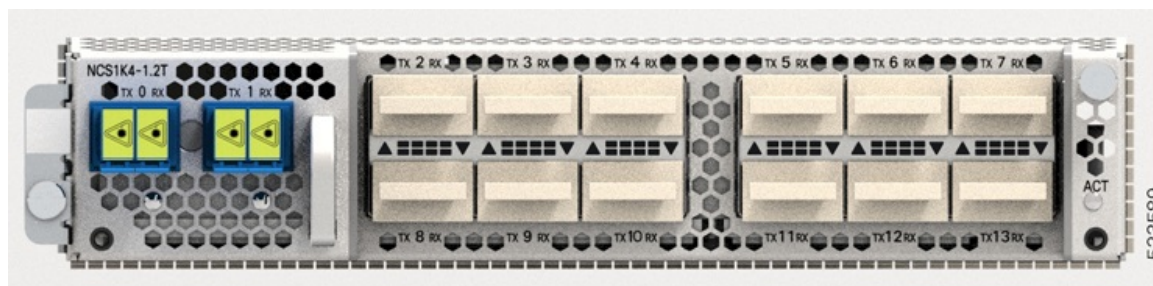



## 2.4TX Line Card

**Table 8: Feature History**

Feature Name	Release Information	Feature Description
NCS1K14-2.4T-X-K9 Line Card	Cisco IOS XR Release 24.1.1	<p>The new <b>NCS1K14-2.4T-X-K9 line card</b> is a single-slot Transponder and Muxponder card that delivers up to 1.2T C-band traffic at each trunk port. It has six QDD client ports that support 400GE and 4x100GE traffic on each port. This card provides two trunk ports that support 1.2T traffic on each port. The <b>mxponder-slice</b> and <b>mxponder</b> keywords in the <b>hw-module</b> command enable this card to operate in the following modes.</p> <ul style="list-style-type: none"> <li>• <b>Muxponder Slice Mode</b>—The card virtually splits into two slices in this mode. It is possible to configure both trunks to carry different data rates. The supported trunk rates are 400G, 500G, 600G, 800G, 1000G, and 1200G.</li> <li>• <b>Muxponder Mode</b>—The card acts as one unit in this mode, configuring both trunks to the same data rate. The supported trunk rates are 600G and 1000G. Additionally, the capacity of a specific shared client port is consumed by two trunk ports.</li> </ul>

The 2.4TX line card is a coherent optics Transponder and Muxponder for the Cisco NCS 1014 chassis. It is a single-slot card that supports C-band traffic at trunk ports. This card delivers 400GE and 100GE client traffic over two trunk ports operating at speeds ranging from 400G to 1.2T each. This card operates in two card modes, namely, the muxponder mode and the muxponder slice mode. In muxponder mode, the client traffic splits between the two trunk ports for 600G and 1000G payloads on port 2 and 3 respectively. In this mode, both trunk ports always carry the same data rate. In muxponder slice mode, both trunk ports act independently, carrying different data rates in each trunk.



**Note** In Release 24.1.1, the 2.4TX line card supports only 400, 500, 600, 800, 1000, and 1200G trunk payloads.

For more information about the 2.4TX card, see [datasheet](#).

In the 2.4TX card, the client and trunk ports support the pluggable form factor and data rates as shown in the following table.

**Table 9: NCS1K14-2.4T-X-K9 Interfaces and Data Rates**

Interfaces	Form Factor	Ports	Data Rates
Client	QSFP-DD56	1, 2, 3, 4, 5, 6	400G
	QSFP-DD112	2, 5	400, 800G
Trunk	Coherent Interface Module 8 (CIM8)	0, 7	up to 1.2T in each port



**Note** In Release 24.1.1, the ports 2 and 5 support only up to 400G data rates.

The 2.4TX card has two trunk ports and six client ports as shown in the following figure.

**Figure 9: 2.4TX Line Card Front View**

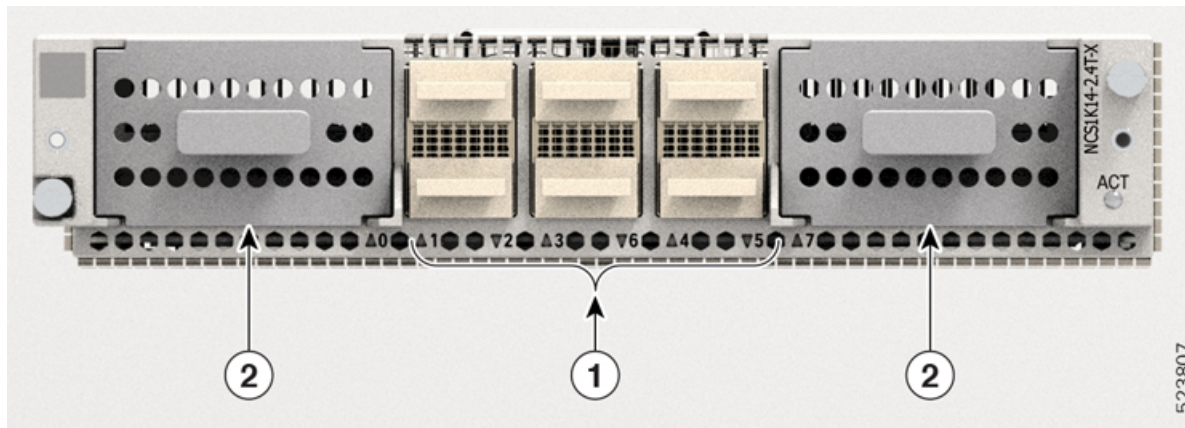

**Table 10: 2.4TX Line Card Interfaces**

Callout	Interface
1	Client port
2	Trunk port

The following figure shows the mapping between the client and trunk ports.

**Figure 10: 2.4TX Card Client and Trunk Mapping**

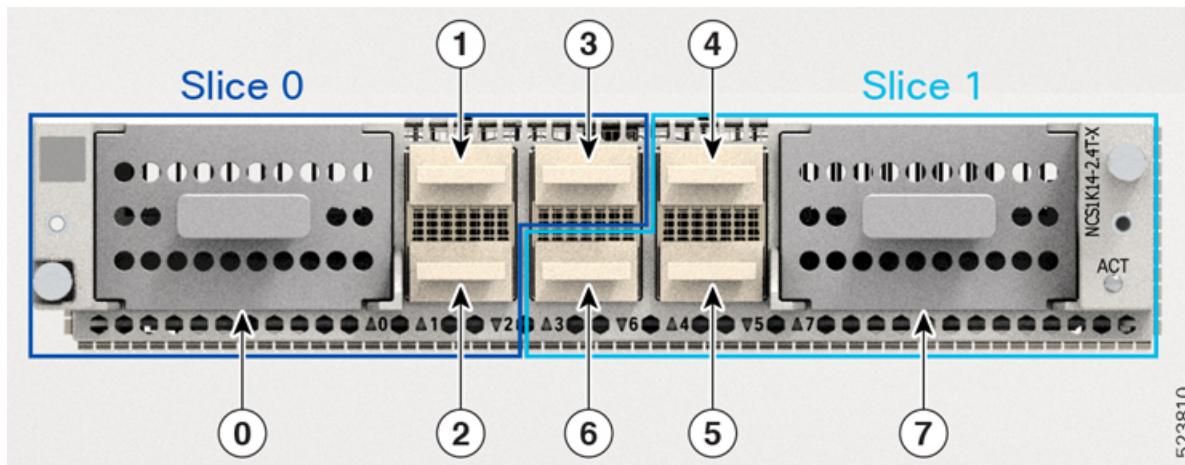

Table 11: Client-to-Trunk Port Mapping

Trunk Port	Client Ports
0	1, 2, 3
7	4, 5, 6



**Note** This client-to-trunk port mapping is only applicable for the mxponder-slice mode.

## QXP-K9 Line Card

The QXP-K9 line card is a high-density QSFP-DD transponder that has eight client ports (QSFP-DD) and eight trunk ports (QSFP-DD ZR+). It is a single-slot card that supports 3.2T traffic through its eight QSFP-DD trunk ports. Each trunk port operates at speed up to 400G in a 50G increment. Each client port supports 400GE, 4x100GE, and 100GE without FEC client rates.

Table 12: QXP-K9 Interfaces

Interfaces	Form Factor	Ports
Client	QSFP-DD	1, 3, 5, 7, 9, 11, 13, 15
Trunk	QSFP-DD	0, 2, 4, 6, 8, 10, 12, 14

The QXP-K9 card has eight trunk ports and eight client ports as shown in the following figure.

Figure 11: QXP-K9 Line Card Front View

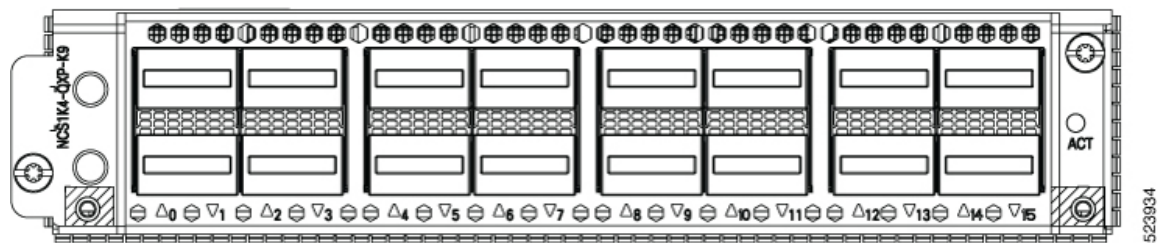

For more details of the QXP-K9 card, see the [data sheet](#).

## Cisco NCS 1014 Modules

The Cisco NCS 1014 chassis supports the following modules:

## Removable SSD

*Table 13: Feature History*

Feature Name	Release Information	Description
Removable NCS1K14-SSD Solid-State Disk (SSD)	Cisco IOS XR Release 7.10.1	The removable <b>NCS1K14-SSD</b> is the redundant SSD in the NCS 1014 chassis. At 2.5” in size, this SSD has 480 GB storage space to store running software and its configuration. This SSD acts as a backup storage to quickly recover the Cisco NCS 1014 chassis after an RP corruption or replacement.

The **NCS1K14-SSD** is the redundant chassis-based SSD in NCS 1014. It is field-replaceable and is accessible from the rear of the Cisco NCS 1014 chassis. This chassis SSD acts as the backup software storage in case the SSD inside the CPU fails. It has 480 GB storage space to store the running software and configuration. This backup storage enables Cisco NCS 1014 to quickly recover to functional state if either route processor (RP) corruption or replacement occurs.

The chassis SSD is 2.5 inch (63.5 mm) and is removable.

*Figure 12: Removable Chassis SSD*

## Fan Modules

The Cisco NCS 1014 chassis has three field-replaceable fan modules (FAN0, FAN1, and FAN2) that cool down the line cards. Each fan module (**NCS1K14-FAN**) has two counterrotating fans—Inlet fan and Outlet fan. Each fan has its own power rail with inrush controller to increase reliability. These counterrotating fans ensure the following benefits:

- Higher back-pressure with respect to a single fan in each module.
- In case a single fan fails, the system can run with 5/6th of the total fans.
- In case a single fan fails, the other fan in the same module prevents the inversion of airflow.



---

**Note** The Cisco NCS 1004 fan modules and the Cisco NCS 1014 fan modules look identical. However, the Cisco NCS 1014 chassis does not support the Cisco NCS 1004 fan modules physically.

---

Each fan module has a cross handle to support lifting, status LED, and side lock lever to secure the module into the chassis.

Figure 13: Perspective View of Fan Module

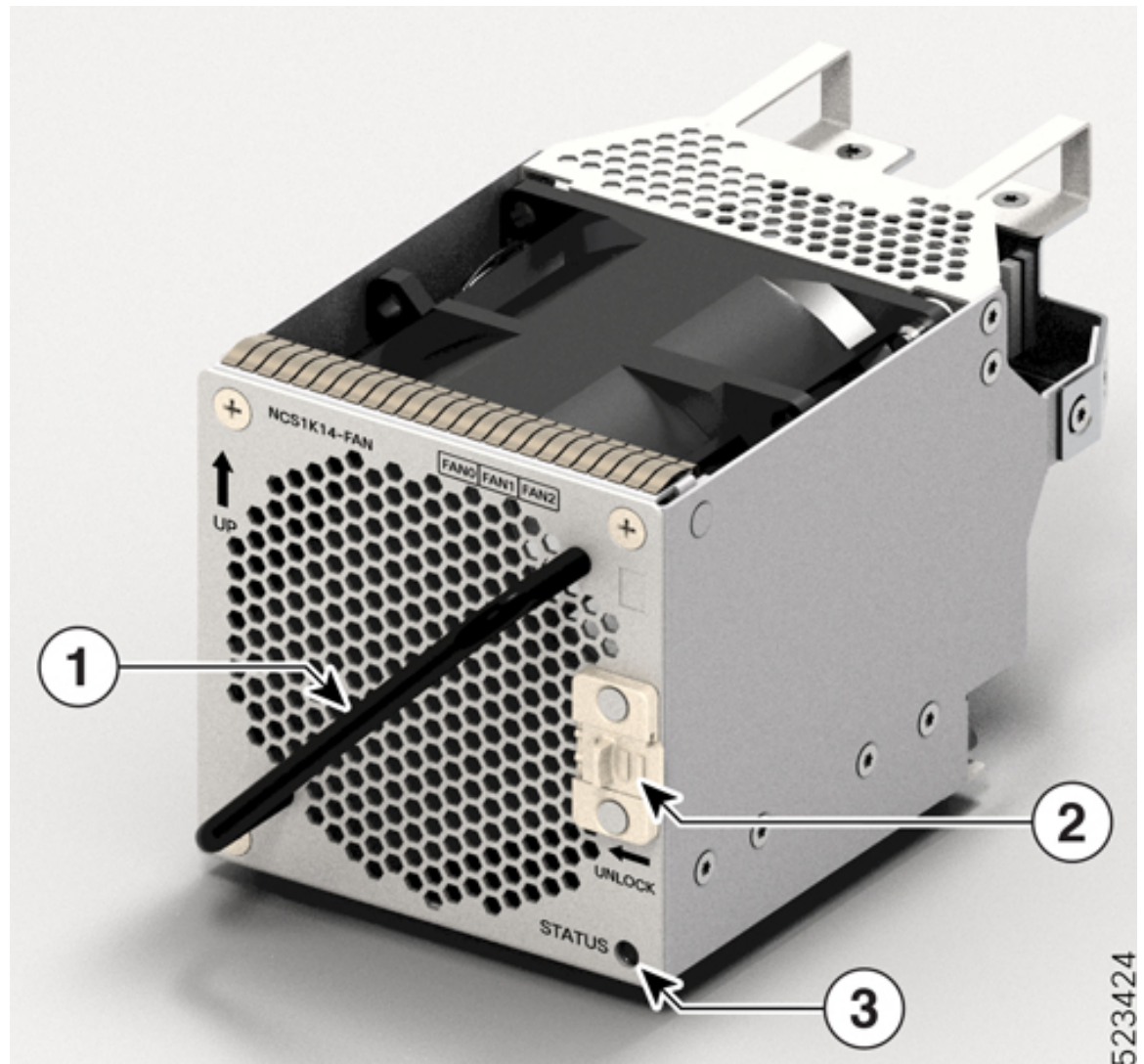

Table 14: Fan Module Components

Callout	Component
1	Cross handle
2	Side lever lock
3	Status LED

## Controller Cards

The Cisco NCS 1014 chassis supports the following controller cards:

- NCS1K14-CNTRLR-B-K9

The NCS1K14-CNTRLR-B-K9 controller card supports a default of 9600-baud rate on the RS-232 console port. The controller card has two USB 2.0, two 10/100/1000 Ethernet, one RS-232 console and two 1GE SFP ports. The SFP port of the controller card supports 1GE payload for PTP. It also has an OIR button and six status LEDs. The controller card provides encryption, remote console connection, PTP and SyncE timing, and GPS.



Figure 14: NCS1K14-CNTRL-B-K9 Controller Card

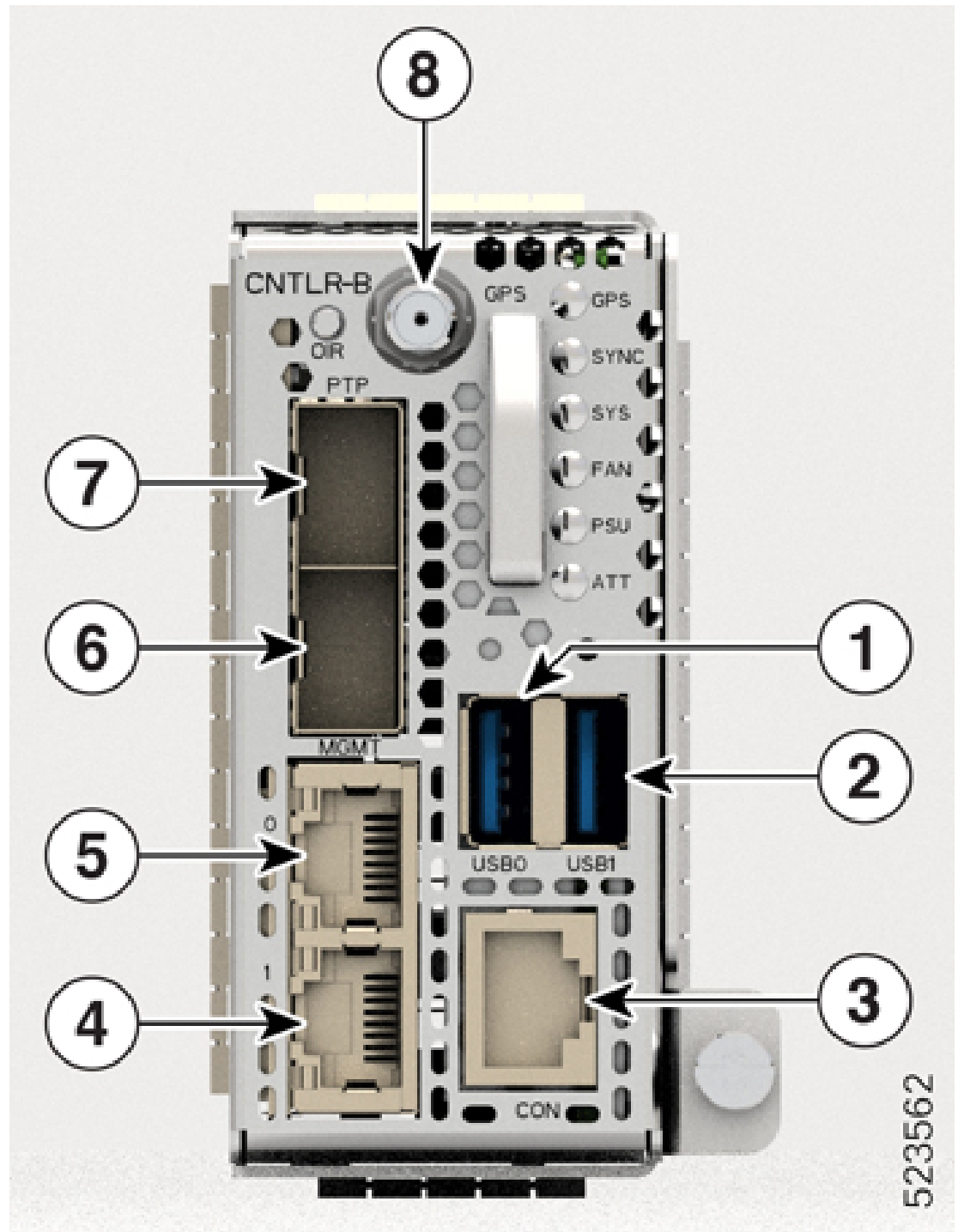

- **NCS1K14-CNTRL-K9**

The NCS1K14-CNTRL-K9 controller card supports a default of 115200-baud rate on the RS-232 console port. The controller card has two USB 2.0, two 10/100/1000 Ethernet, one RS-232 console and two 1GE

SFP ports. The SFP port of the controller card supports 1GE payload for PTP. It also has an OIR button and six status LEDs. The controller card provides encryption, remote console connection, PTP and SyncE timing, and GPS.

Figure 15: NCS1K14-CNTRLR-K9 Controller Card

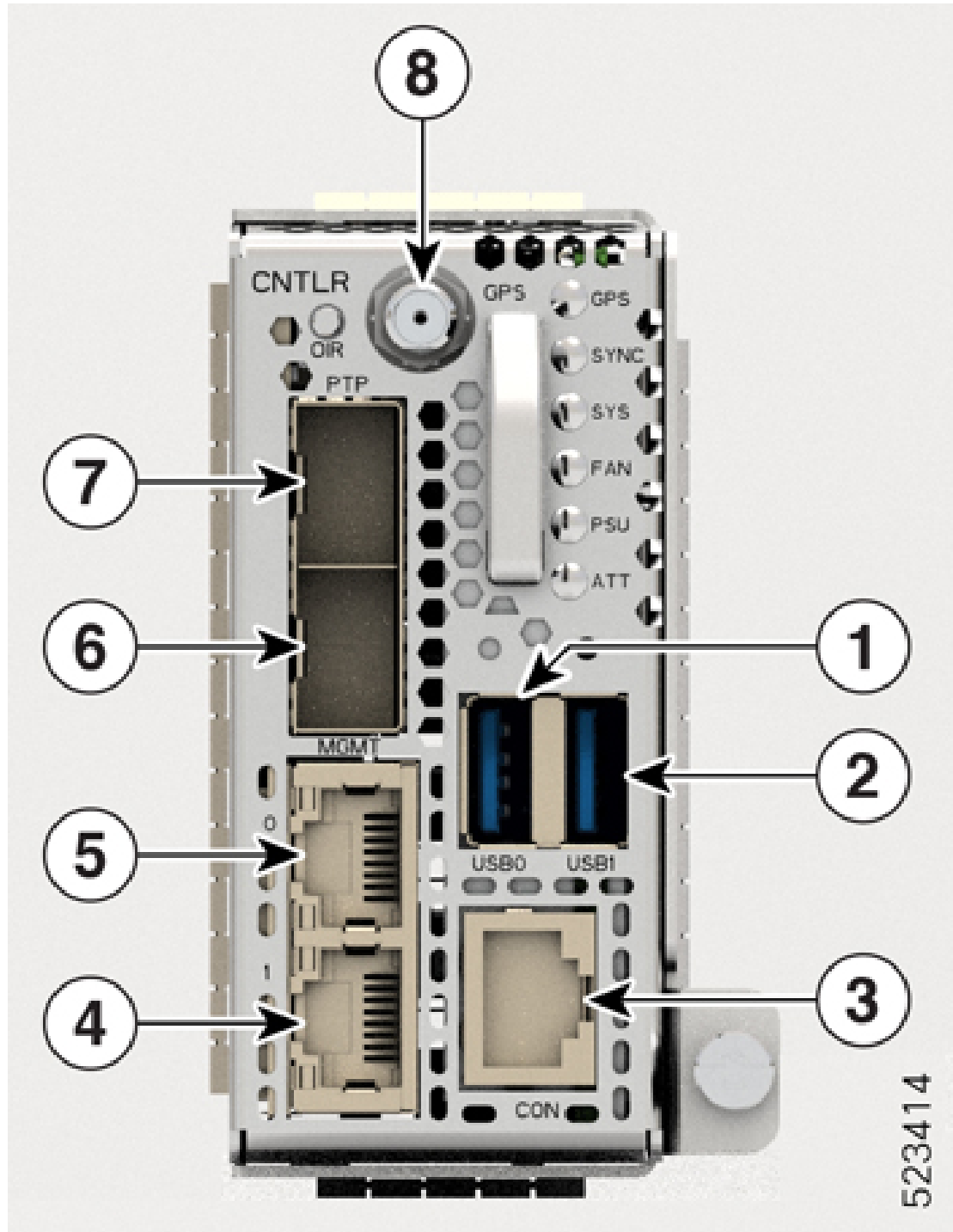

Table 15: Controller Card Interfaces

Callout	Interface	Description
1, 2	USB 0 and 1	External USB port. USB 2.0 type A, 1.8 A max at 12 V provides support to external passive optical modules (2x)  The USB ports have following functions: <ul style="list-style-type: none"> <li>• Essential—boot the image through pen drive (Only USB 2.0 sticks and pen drives are supported).</li> <li>• Optional—copy files to and from local devices (Only USB 2.0 sticks and pen drives are supported).</li> </ul>
3	CON	Console interface (1x)  <b>Note</b> Set the DTR (Data Terminal Ready) value to 1 to enable the CON interface.
4, 5	MGMT 0 and 1	10/100/1000 RJ-45 Ethernet management ports (2x)
7, 6	PTP 0 and 1	SFP for 1GE optical PTP ports (1588-nm PTP and SyncE) (2x)
8	GPS	Coaxial connector for GPS antenna RF input (with 5 V antenna power, if necessary) (1x)

## Power Supply

The Cisco NCS 1014 chassis has two slots for 2.5-kW AC and DC redundant PSUs. Both the PSUs must always remain installed in the chassis, except during replacement. When the chassis has only one PSU installed, the system raises the *Power Module Redundancy Lost* alarm. The Cisco NCS 1014 chassis also supports 2-kW AC and DC PSUs.

### 2.5-KW PSUs (NCS1K4-AC-PSU-2 and NCS1K4-DC-PSU-2)

2.5-kW PSU power derating and option table, including ambient temperature details are here. The power details are for output power.

- AC high voltage range output power—2500 W up to 40°C for 1 PSU; 2500 W up to 55°C for 2 PSUs (for a short duration, as specified by Telcordia GR-63-Core).
- AC low voltage range output power—1500 W up to 40°C for 1 PSU; 1500 W up to 55°C for 2 PSUs (for a short duration, as specified by Telcordia GR-63-Core).
- DC power supply—2500 W output power up to 40°C for 1 PSU; 2500 W up to 55°C for 2 PSUs (for a short duration, as specified by Telcordia GR-63-Core).

### For DC-DC (2500 W at 12 Vout)

- Input Voltage Rating = -48...-60 Vdc
- Maximum Input current at -48 Vdc = 60 A
- Input Voltage range = -40...-72 Vdc (operating)

- Input turn ON Voltage =  $-41 \dots -42$  Vdc maximum
- Recommended protective device rating = 90 A maximum per feed

#### For the AC-DC (2500 W (HL) / 1500 W (LL) at 12 Vout)

- Input Low Line (LL) Nominal voltage = 100–120 V~
- Input High Line (HL) Nominal voltage = 200–230 V~
- Maximum Input current at 100 V~ = 16 A
- Maximum Input current at 200 V~ = 14 A
- Input frequency rating = 50/60 Hz
- Input LL voltage range = 90–140 V~
- Input HL voltage range = 180–264 V~
- Input frequency range = 47–63 Hz (nominal 50/60Hz)
- Minimum Input turn ON voltage = 85 V~ / 175 V~ (LL/ HL)
- Maximum Input turn ON voltage = 90 V~ / 180 V~ (LL/ HL)
- Recommended protective device (HL) = 16 A
- Recommended protective device (LL) = 20 A

#### 2-KW PSUs (NCS1K4-AC-PSU and NCS1K4-DC-PSU)

2-kW PSU power derating and option table, including ambient temperature details are here. The power details are for output power.

- AC high voltage range output power—2000 W up to 40°C for 1 PSU; 2000 W up to 55°C for 2 PSUs (for a short duration, as specified by Telcordia GR-63-Core).
- AC low voltage range output power—1300 W up to 40°C for 1 PSU; 1300 W up to 55°C for 2 PSUs (for a short duration, as specified by Telcordia GR-63-Core).
- DC power supply—2000 W output power up to 40°C for 1 PSU; 2000 W up to 55°C for 2 PSUs (for a short duration, as specified by Telcordia GR-63-Core).



---

**Caution** The NCS 1014 chassis must have both the PSUs at all times. In case one of the PSUs is not energized (due to a fault or missing mains), ensure that the system works at an ambient temperature of not more than 40°C.

---

#### For DC-DC (2000 W at 12 Vout)

- Input Voltage Rating =  $-48$  Vdc /  $-60$  Vdc
- Maximum Input current at 48 Vdc = 44 A
- Input Voltage range = 40.5–72 Vdc (operating)
- Input turn ON Voltage =  $-42$  Vdc maximum

- Recommended protective device rating = 60 A maximum per feed

**For the AC-DC (2000 W (HL) / 1300 W (LL) at 12 Vout)**

- Input Low Line (LL) Nominal voltage = 100–127 V~
- Input High Line (HL) Nominal voltage = 200–240 V~
- Maximum Input current at 100 V~ = 15 A
- Maximum Input current at 200 V~ = 12 A
- Input frequency rating = 50/60 Hz
- Input LL voltage range = 90–140 V~
- Input HL voltage range = 180–264 V~
- Input frequency range = 47–63 Hz (nominal 50/60 Hz)
- Input turn ON voltage = 80 V~ / 175 V~ (LL/ HL)
- Recommended protective device (HL) = 16 A
- Recommended protective device (LL) = 20 A

For the trip time response, the breaker trip curve may be "D" or faster.

## Power Supply Units (PSUs)

The redundant, field-replaceable PSUs power the Cisco NCS 1014 chassis. The chassis has slots for two PSUs at the rear side. Each PSU supports up to 2.5 kW per system.

The PSUs have internal fans to regulate the temperature inside the PSUs. The fans in the PSU receive power from the main PSU or the standby PSU. The PSUs are available in reverse airflow (RAF) direction meaning the airflow direction is from the output connector to the input connector.

To ensure the necessary fan redundancy, the two PSUs implement a protection mechanism. When the mechanism detects a single PSU failure or if a PSU fails to power up, it triggers all the operational fans to run at maximum speed. This mechanism activates without intervention from the software.

The Cisco NCS 1014 chassis supports the following PSUs:

- **NCS1K4-AC-PSU-2**

NCS1K4-AC-PSU-2 is a 2.5-kW AC to DC, power-factor-corrected (PFC) power supply that converts standard AC power into a main output of 12 VDC.

Figure 16: NCS1K4-AC-PSU-2

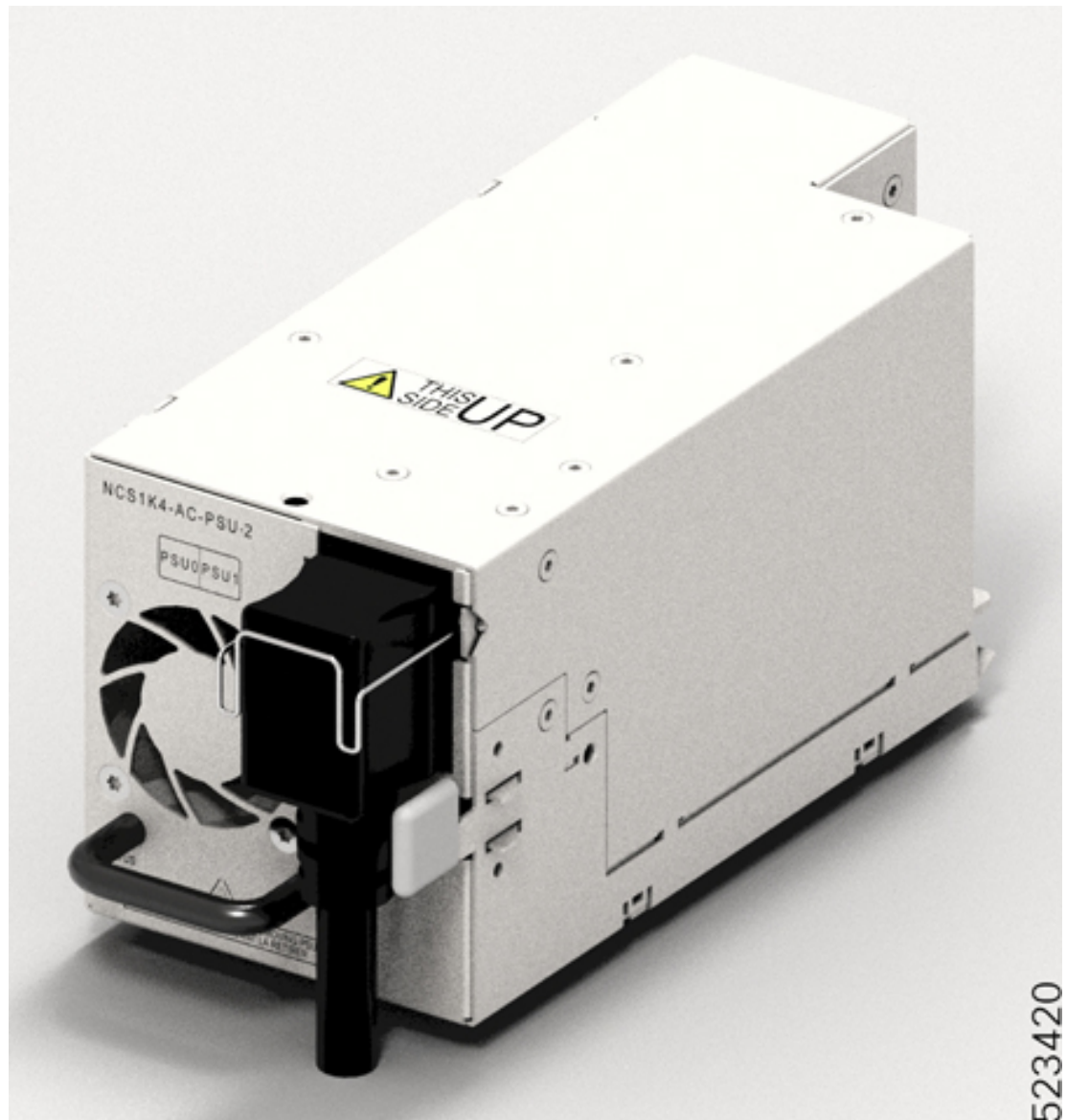

- **NCS1K4-DC-PSU-2**

NCS1K4-DC-PSU-2 is a 2.5-kW DC to DC, PFC power supply with 12 VDC (main) and 12 VDC (standby) output.

Figure 17: NCS1K4-DC-PSU-2

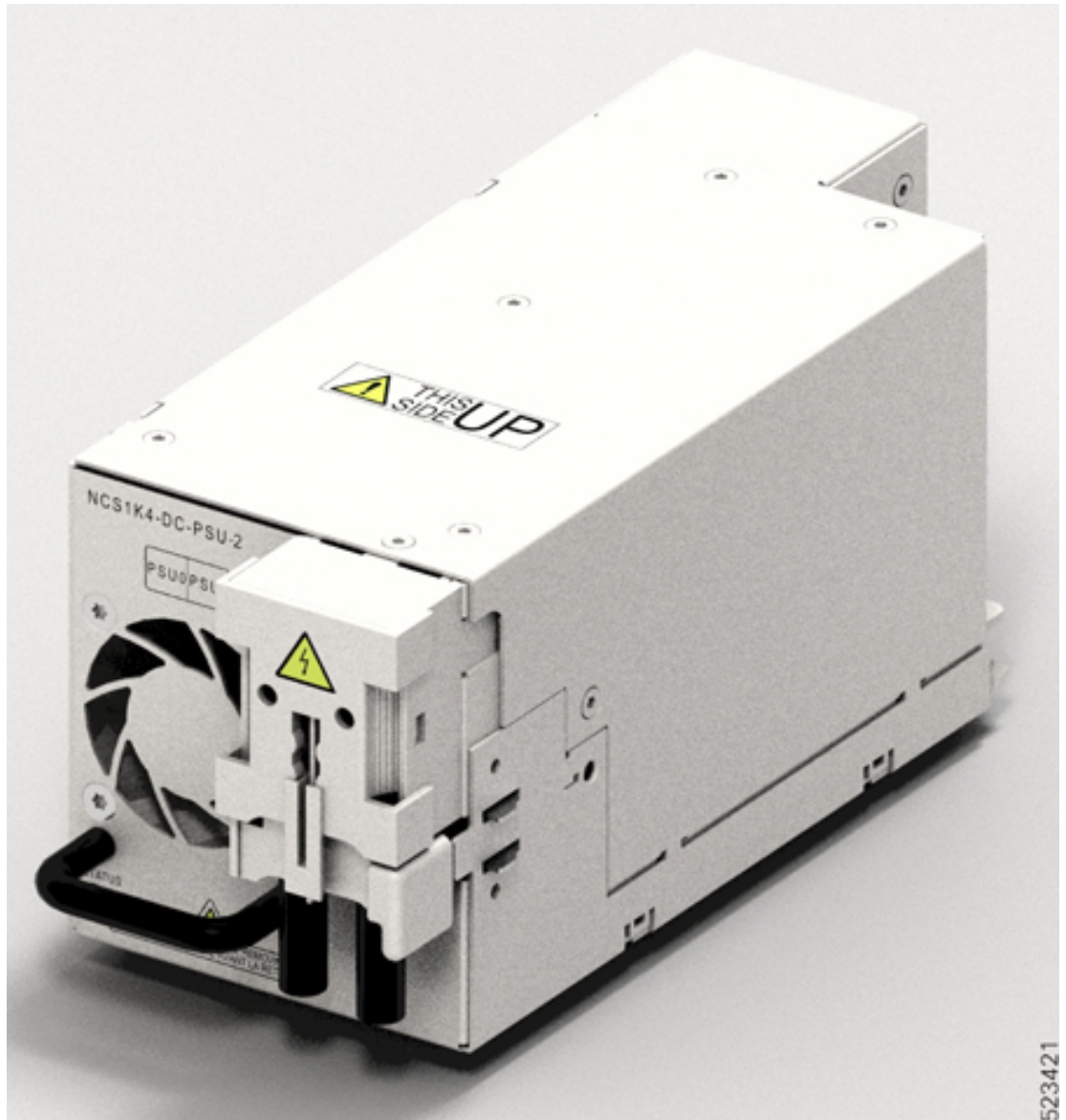

- **NCS1K4-AC-PSU**

NCS1K4-AC-PSU is a 2-kW AC to DC, PFC power supply that converts standard AC power into a main output of 12 VDC.

- **NCS1K4-DC-PSU**

NCS1K4-DC-PSU is a 2-kW DC to DC, PFC power supply with 12 VDC (main) and 12 VDC (standby) output.

## Air Filter

The air filter removes dust from the air that the fan units draw into the chassis. If the air filters become damaged, dirty, or clogged with dust, you must replace them with a new air filter. Failure to replace a compromised air filter can result in insufficient air circulation through the chassis and temperature-related environmental alarms.

The Cisco NCS 1014 air filter has the following components:

- Two air filter side brackets
- One air filter frame
- One air filter

You must order all the three components for the first-time installation. After first-time installation of the air filter unit, replace only the air filter. You reuse the air filter side brackets and the frame.



**Note** First inspection of the air filter must be performed six months after the first installation of the air filter. Air filters must be inspected every three months after the initial six-month inspection and replaced if found to be dirty. Do not reuse the cleaned air filters. Replace them with a new air filter. We recommend having spare air filters in stock.

## Supported Pluggables

*Table 16: Feature History*

Feature Name	Release	Description
Pluggables Support	Cisco IOS XR Release 24.3.1	<p>This client pluggable is supported on the QXP card:</p> <ul style="list-style-type: none"> <li>• QDD-400G-LR4-S</li> </ul> <p>This trunk pluggable is supported on the QXP card:</p> <ul style="list-style-type: none"> <li>• QDD-400G-ZR-S</li> </ul> <p>These client pluggables are supported on the 2.4TX card:</p> <ul style="list-style-type: none"> <li>• QDD-2X100-CWDM4-S</li> <li>• QDD-2X100-LR4-S</li> </ul> <p>These trunk pluggables are supported on the 2.4TX card:</p> <ul style="list-style-type: none"> <li>• CIM8-CE-K9=</li> <li>• CIM8-LE-K9=</li> </ul>



Feature Name	Release	Description
Pluggables Support	Cisco IOS XR Release 24.2.11	The following pluggables are supported on the NCS1K14-2.4-T-X-K9 card: <ul style="list-style-type: none"> <li>• QDD-400G-LR4-S</li> <li>• QDD-4X100G-FR-S</li> </ul>

### 2.4TX Line Card Pluggables

The 2.4TX line card supports the following pluggables:

**Table 17: 2.4TX Line Card Pluggables**

Client Pluggables	Trunk Pluggables
<ul style="list-style-type: none"> <li>• QDD-400G-FR4-S</li> <li>• QDD-400G-AOCxM</li> <li>• QDD-400G-DR4-S</li> <li>• QDD-4X100G-LR-S</li> <li>• QDD-400G-LR4-S</li> <li>• QDD-4X100G-FR4-S</li> <li>• QDD-2X100-CWDM4-S</li> <li>• QDD-2X100-LR4-S</li> </ul>	<ul style="list-style-type: none"> <li>• CIM8-C-K9=</li> <li>• CIM8-CE-K9=</li> <li>• CIM8-LE-K9=</li> </ul>

### 2.4T Line Card Pluggables

The 2.4T line card supports the following pluggables:

**Table 18: 2.4T Line Card Pluggables**

Client Pluggables	Trunk Pluggables
<ul style="list-style-type: none"> <li>• QDD-400G-FR4-S</li> <li>• QDD-400G-AOCxM</li> <li>• QDD-400G-DR4-S</li> <li>• QDD-4X100G-LR-S</li> <li>• QDD-2X100-CWDM4-S</li> <li>• QDD-2X100-LR4-S</li> </ul>	<ul style="list-style-type: none"> <li>• CIM8-C-K9=</li> </ul>

For more information on the 400G client pluggables, see [Cisco 400G QSFP-DD Cable and Transceiver Modules Data Sheet](#).

### 1.2T Line Card Pluggables

The 1.2T line card supports the following pluggables:

- QSFP-100G-SR4-S
- QSFP-100G-CWDM4-S
- QSFP-100G-SM-SR
- QSFP-100G-AOC-1M
- QSFP-100G-AOC-3M
- QSFP-100G-AOC-10M
- QSFP-100G-LR4-S
- QSFP-100G-CU1M
- QSFP-100G-CU2M
- QSFP-100G-CU3M
- QSFP-100G-CU5M
- QSFP-100G-DR-S
- QSFP-100G-FR-S
- QSFP-100G-LR-S
- ONS-QSFP28-LR4
- QSFP-40/100-SRBD
- QSFP-100G-ER4L-S

### QXP Card Pluggables

The QXP card supports the following pluggables:

**Table 19: QXP Line Card Pluggables**

Client Pluggables	Trunk Pluggables
<ul style="list-style-type: none"> <li>• QDD-400G-FR4-S</li> <li>• QDD-400G-DR4-S</li> <li>• QDD-400-AOCxM</li> <li>• QDD-4x100G-LR-S</li> <li>• QDD-400G-LR4-S</li> </ul>	<ul style="list-style-type: none"> <li>• DP04QSDD-HK9</li> <li>• DP04QSDD-LK9</li> <li>• DP04QSDD-HE0</li> <li>• QDD-400G-ZR-S</li> <li>• QDD-400G-ZRP-S</li> </ul>