



LEDs

This section provides details of the LEDs in the Cisco NCS 1014 modules, controller unit and line card.

- [Line Card LEDs, on page 1](#)
- [Controller LEDs, on page 7](#)
- [Power Supply Unit \(PSU\) LED, on page 10](#)
- [Fan Module LED, on page 11](#)

Line Card LEDs

The Cisco NCS 1014 line cards use LEDs to indicate the overall state of the cards and help you verify the status of specific connections, ports, and system components. The following topics identify these LEDs and explain what they mean.



Note

- "2.4T" refers to the NCS1K14-2.4T-K9 line card.
 - "CCMD-16-C" refers to the NCS1K14-CCMD-16-C C-band optical line card.
 - "CCMD-16-L" refers to the NCS1K14-CCMD-16-L optical line card.
 - "1.2T" refers to the NCS1K4-1.2T-K9 line card.
 - "2.4TX" refers to the NCS1K14-2.4T-X-K9 line card.
 - "QXP-K9" refers to the NCS1K4-QXP-K9 line card.
-

2.4T and 2.4TX Line Cards LED

The 2.4T and 2.4TX line cards have nine LEDs to indicate the line port alarm status.

Figure 1: 2.4T Line Card LEDs

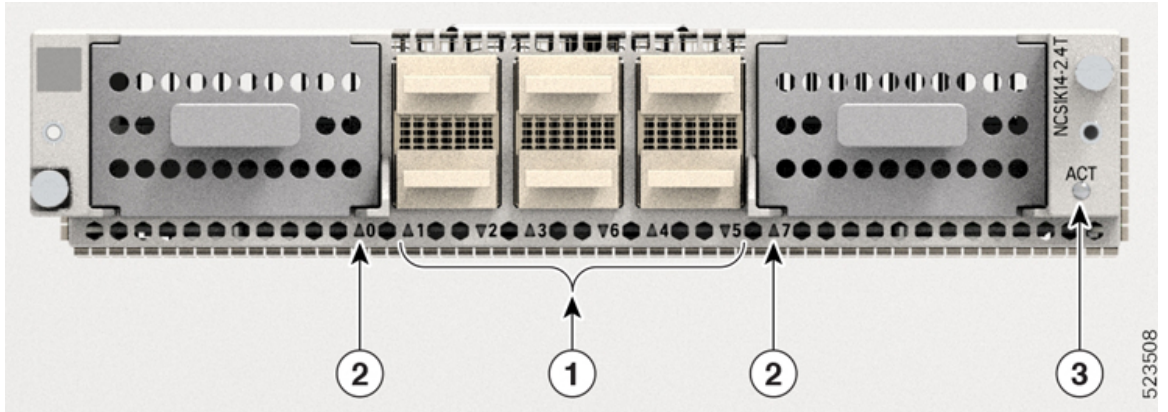
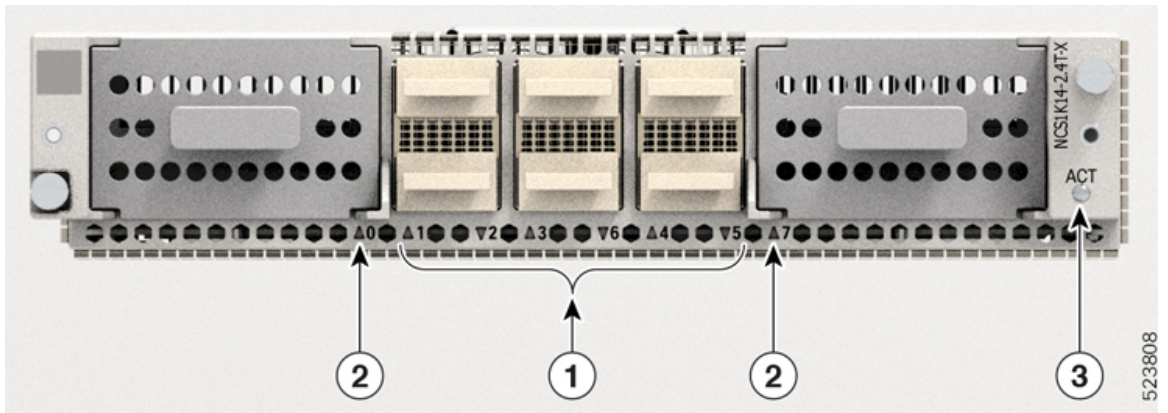

Figure 2: 2.4TX Line Card LEDs



Callout	LED
1	QSFP port (1–6) LEDs The card cage embeds the QSFP LEDs. The <i>triangles</i> appearing upwards and downwards indicate the status and position of the corresponding QSFP.
2	Trunk port (0 and 7) LEDs
3	ACT LED



Note The following LED status applies to both 2.4T and 2.4TX line cards.

Table 1: Status of the Line Card LEDs

LED	Color	Status
ACT LED ¹	Amber (solid)	The line card is booting. This color appears as soon as the line card is inserted into the chassis.
	Flashing Red	The line card is in the booting phase.
	Green	The line card is up and operational (not associated to the traffic status).
QSFP and Trunk port LEDs (0...7)	Off	The port remains not provisioned or switched off.
	Green	The module is operational and has no alarm.
	Amber (solid)	Minor alarm (such as low Rx or Tx power) that could lead to a traffic-impacting situation.
	Amber (flashing)	Used for troubleshooting. Identifies the faulty port of an LC. Use the controller optics command in the configuration mode to point to a faulty port in the line card. The port is configured in maintenance mode or the attention LED is enabled for this port. Use hw-module location to enable the attention LED for the port.
	Red	Major alarm that could lead to a traffic-impacting situation.

¹ ACT LED does not support Attention LED.

CCMD-16-C and CCMD-16-L Line Card LED

The CCMD-16-C and CCMD-16-L optical line cards have 18 LEDs each to indicate the system status and the status of the optical ports.

The following information applies to both CCMD-16-C and CCMD-16-L cards.

Figure 3: CCMD-16-C Optical Cards LEDs

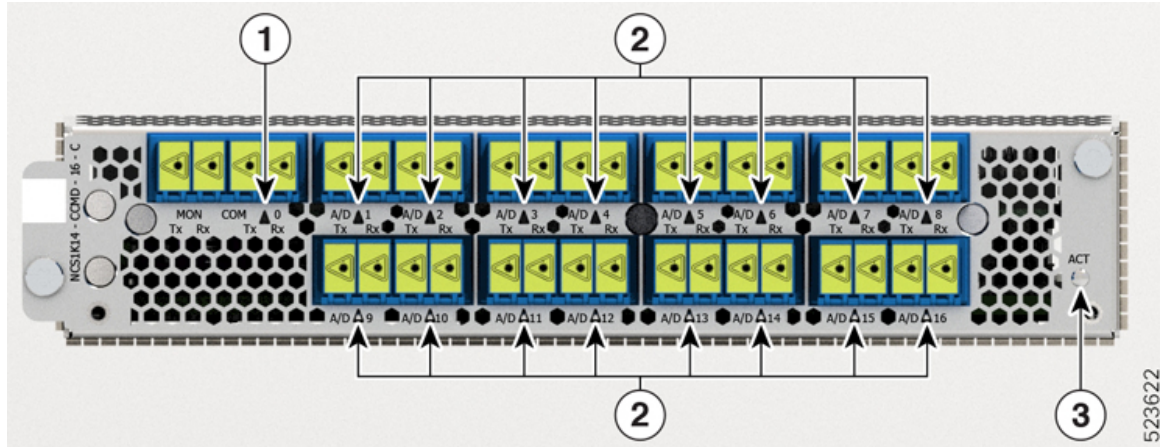

Callout	LED
1	COM
2	A/D-1...A/D-16
3	ACT

Table 2: Status of the CCMD-16-C and CCMD-16-L Optical Card LEDs

LED	Color	Status
ACT	Amber (solid)	The line card is booting. This color appears when you insert the line card into the chassis.
	Flashing Red	The line card is faulty.
	Green	The line card is up and operational—not associated to the traffic status.

LED	Color	Status
COM, A/D-1...A/D-16	Off	The port is not provisioned.
	Red	Major alarm that could lead to a traffic impacting situation.
	Green	The module is operational and has no alarm.
	Amber (solid)	Minor alarm (such as low Rx or Tx power) that could lead to a traffic impacting situation.
	Amber (flashing)	This is used for troubleshooting, to identify the faulty port of an LC. Use the controller optics command in the configuration mode to point to a faulty port in the LC. The port is configured in maintenance mode or the attention LED is enabled for this port. Note Attention LED is not supported on ACT LED.

1.2T Line Card LEDs

The 1.2T line card has 14 LEDs to indicate the line port alarm status.

Figure 4: 1.2T Line Card LEDs

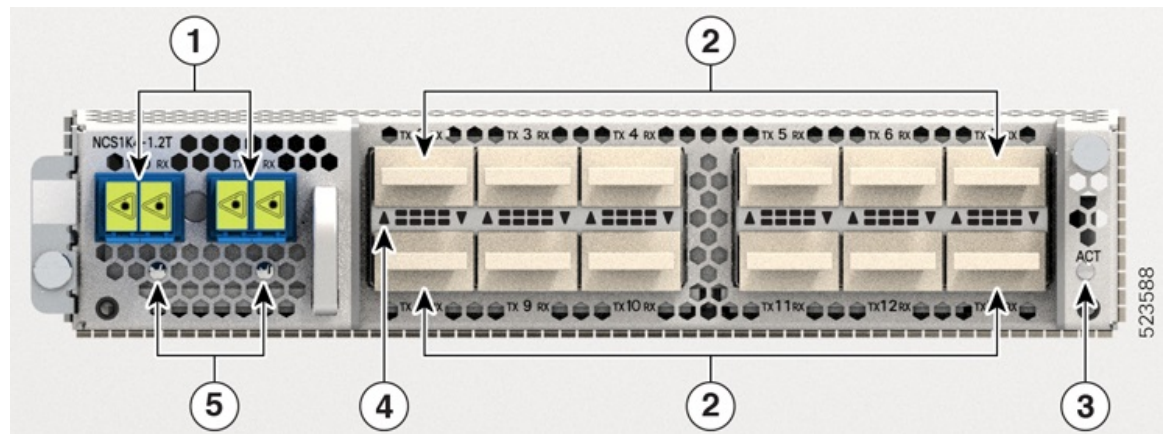

1	Trunk ports (0 and 1)
2	12 QSFP ports (2 to 13). Each QSFP port has Attention LED.
3	ACT LED
4	QSFP port LEDs The LEDs for the QSFPs are embedded in the card cage. The <i>triangles</i> shown upwards or downwards (in 1.2T and 1.2TL line cards) indicate the status of the corresponding QSFP.

5	Trunk port LEDs
---	-----------------

Table 3: Status of the Line Card LEDs

LED	Color	Status
Attention LED	Yellow Flashing	Used by the field engineers to identify a specific port in the line card. This is used for troubleshooting purposes. <ul style="list-style-type: none"> • Use the hw-module location locationattention-led all-ports command to turn on this LED on all the ports of the line card. • Use the hw-module location locationattention-led port-number command to turn on this LED on a specific port of the line card. • Use the show controllers optics rack/slot/instance/port in LED command to display the LED status of ports.
ACT LED	Amber (solid)	The line card is booting. This colour appears as soon as the line card is inserted in to the chassis.
	Flashing Red	The line card is in the booting phase.
	Green	The line card is up and operational (not associated to the traffic status).
QSFP and Trunk port LEDs	Off	The port has not been provisioned.
	Red	Major alarm that could lead to a traffic-impacting situation.
	Green	Indicates that the module is operational and has no alarm.
	Amber (solid)	Indicates a minor alarm (such as low Rx or Tx power), which could lead to a traffic impacting situation.
	Amber (flashing)	This is used for troubleshooting, to identify the faulty port of a line card. Use the controller optics command in the configuration mode to point to a faulty port in the line card. The port is configured in maintenance mode or the attention LED is enabled for this port. Note Attention LED is not supported on ACT LED.

QXP Line Card LED

The front view of the QXP-K9 line card is as below.

Figure 5: Front View of the QXP-K9 Line Card

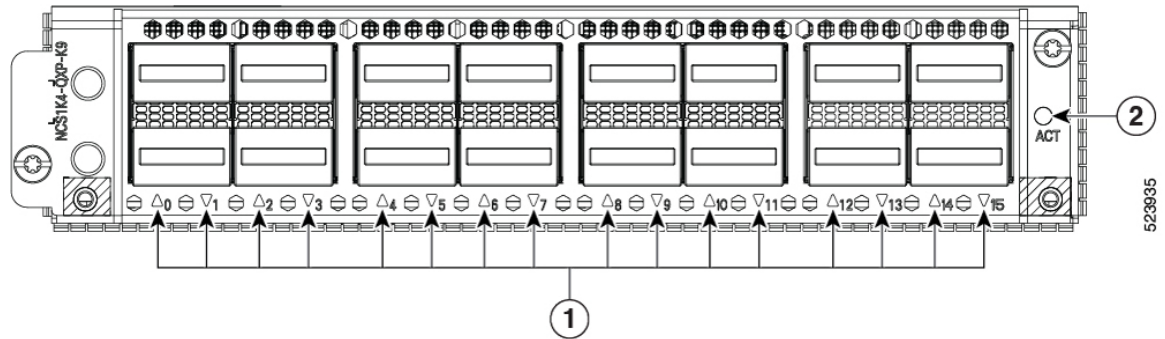

1	16 QSFP-DD ports (0 to 15)
2	ACT LED

Table 4: Status of the QXP-K9 Line Card LEDs

LED	Color	Status
ACT LED	Flashing Red	The line card is booting. This color appears as soon as the line card is inserted in to the chassis.
	Amber (solid)	Indicates that the line card is in the booting phase.
	Green	Indicates that the line card is up and operational (not associated to the traffic status).
QSFP-DD port LEDs	Off	This indicates that the port has not been provisioned.
	Red	Indicates a major alarm, which could be a traffic impacting situation.
	Green	Indicates that the module is operational and has no alarm.
	Amber (solid)	Indicates a minor alarm (such as low Rx or Tx power), which could lead to a traffic impacting situation.
	Amber (flashing)	This is used for troubleshooting, to identify the faulty port of a line card. Use the controller optics command in the configuration mode to point to a faulty port in the line card.

Controller LEDs

The controllers have six LEDs to indicate the system status and the status of the components.

Figure 6: CNTLR LEDs

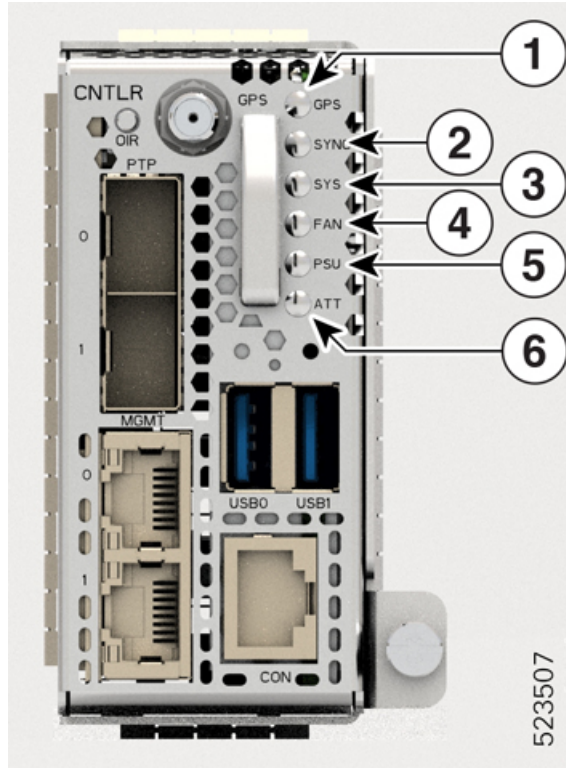
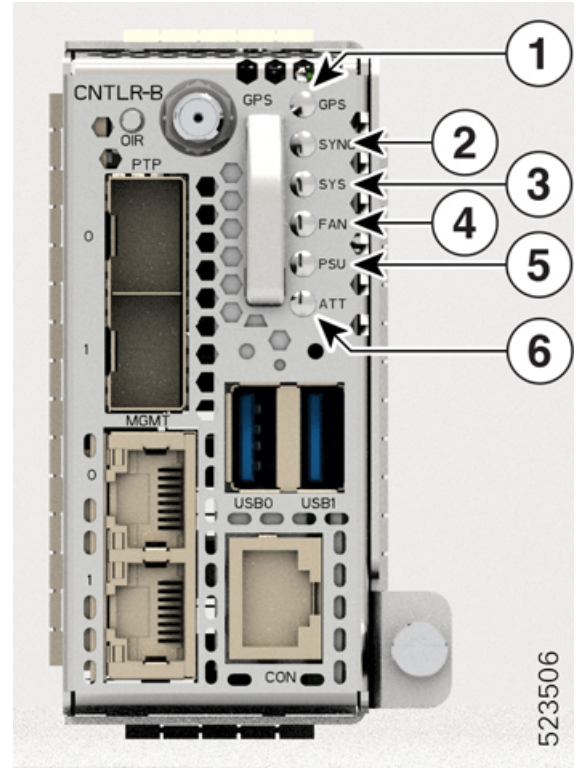

Figure 7: CNTLR-B LEDs



Callout	LED	Callout	LED
1	GPS LED	4	Fan Unit Status (FAN) LED
2	Synchronous Ethernet (SYN) LED	5	Power Supply Unit Status (PSU) LED
3	System Status (SYS) LED	6	Attention (ATT) LED

Table 5: Status of the Controller LEDs

LED	Color	Status
GPS	Green	GPS phase locked.
	Yellow	GPS enabled.
	Off	GPS not enabled.
	Red	GPS is in use.

LED	Color	Status
SYNC	Green	Time core becomes synchronized to an external source including IEEE1588.
	Flashing green	System is in Synchronous Ethernet mode.
	Amber	Acquiring state or Holdover: Time core is in acquiring state or holdover mode.
	Off	Time core clock synchronization has become disabled or is in a free-running state.
SYS (during controller boot up)	Red	The controller unit is powering on.
	Red (flashing slowly)	BIOS loading.
	Amber (flashing slowly)	OS loading.
	Red (flashing fast)	Secure boot failure. Replace the controller unit.
	Amber (flashing fast)	XR loading.
SYS (controller is operational)	Red	Major or critical alarm is present.
	Amber	Minor alarm is present.
	Green	The module is operational and has no active alarms.
PSU	Green	All PSUs present in the chassis are in working condition.
	Red	Either a PSU is missing from its slot or is faulty.
FAN	Green	All fans present in the chassis are in working condition.
	Red	Either a fan is missing from its slot or is faulty.

LED	Color	Status
ATT	Blue (flashing)	Applicable during online insertion and removal (OIR) procedures. The system is cooling down.
	Blue	Used to identify a specific chassis in a rack or room. Use this LED for troubleshooting purposes. Run the hw-module attention led location command to turn on this LED.

Power Supply Unit (PSU) LED

The NCS1K4-AC-PSU-2 and NCS1K4-DC-PSU-2 units have one LED each to indicate their status.

Figure 8: Front View of 2.5-kW AC PSU

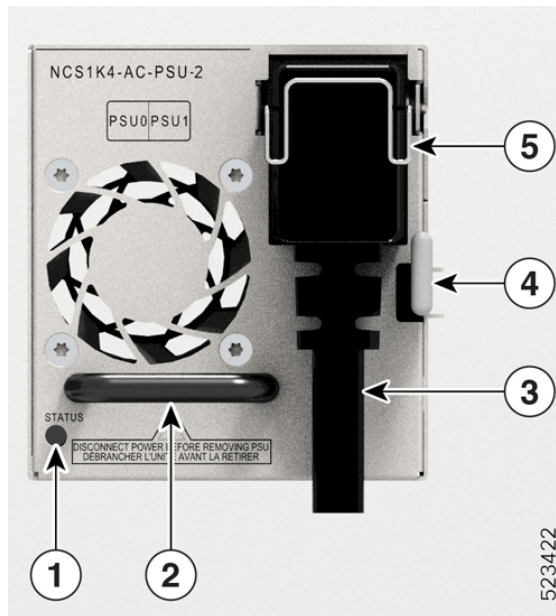
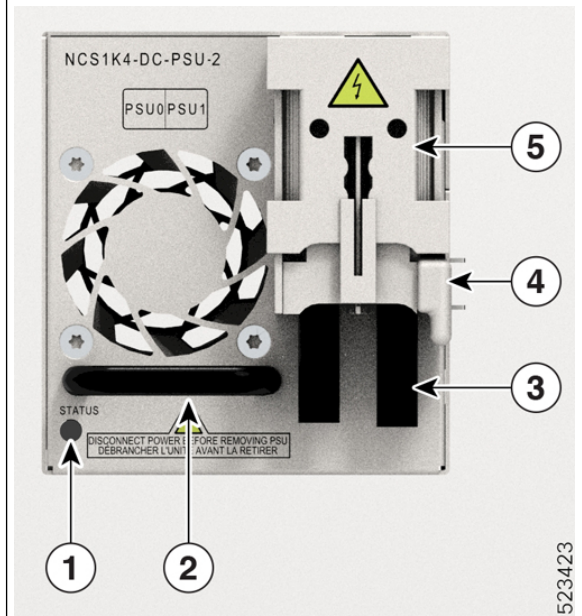

Figure 9: Front View of 2.5-kW DC PSU



1	PSU Unit (STATUS) LED	4	Locking latch
2	PSU Handle	5	Protective cover
3	6 AWG 180-degree exit cables		

Table 6: Status of the 2.5-kW PSU LED

Color	Status
Amber	There exists no input to the PSU, provided the other PSU is working.

Color	Status
Off	Both PSUs do not have input.
Green	The input to the PSU is valid.

For 2-kW PSU LEDs, see [Power Supply Unit LED](#)

Fan Module LED

Each fan module has one LED to indicate its status.

Figure 10: Front View of the Fan Module

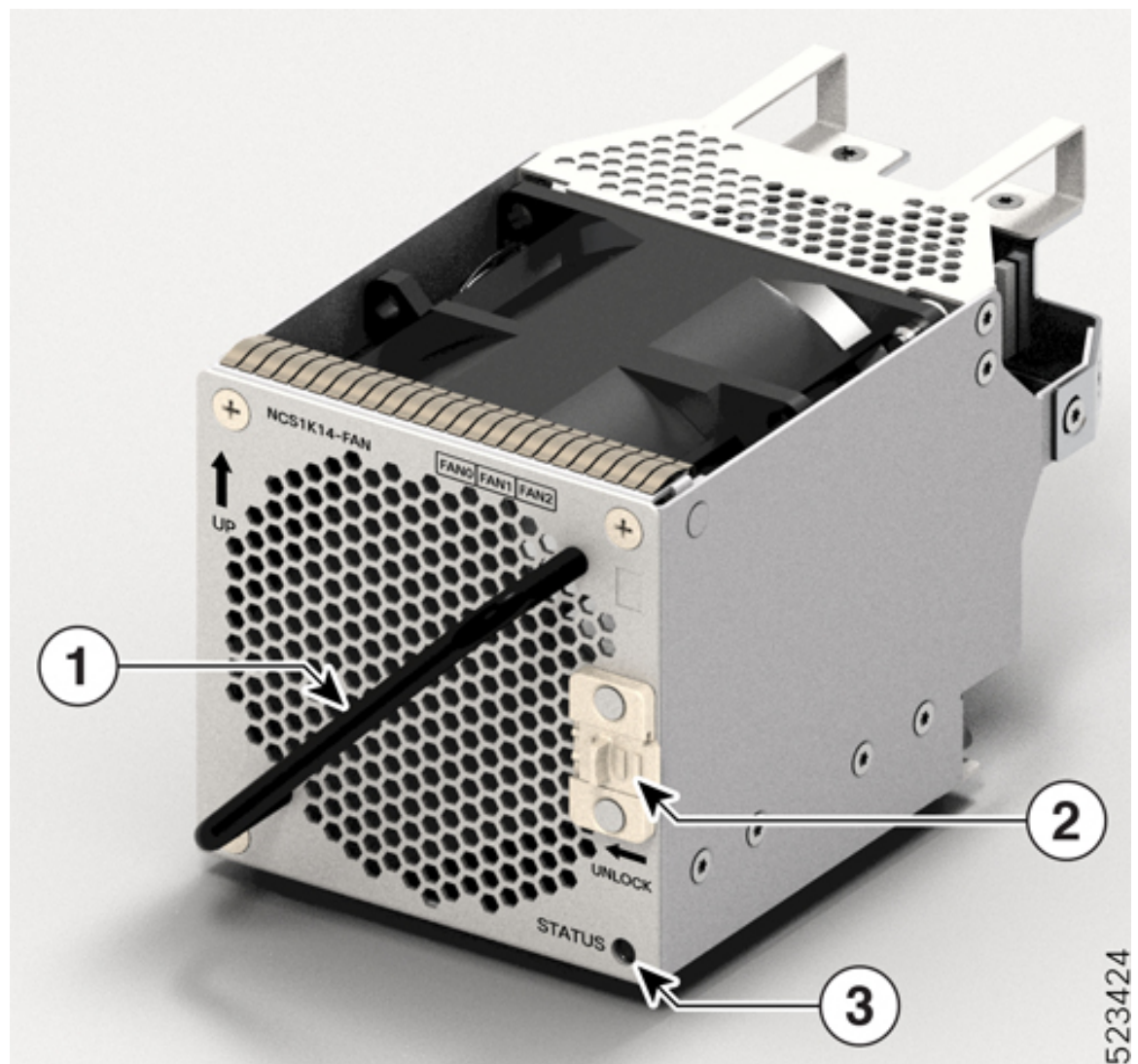

1	Cross-handle
---	--------------

2	Spring-loaded Lever
3	Fan Module (STATUS) LED

Table 7: Status of the Fan Module LED

LED	Color	Status
STATUS	Red	Fault found in the fan module. This status occurs for the following reasons: <ul style="list-style-type: none"> • Fan speed is out of range. • Or the inserted fan module does not power on. • Or the fan module is not present.
	Green	Fan module is working fine.