



CHAPTER 15

Performance Monitoring

Performance monitoring (PM) parameters are used by service providers to gather, store, set thresholds for, and report performance data for early detection of problems. In this chapter, PM parameters and concepts are defined for electrical cards, ethernet cards, optical cards, optical multirate cards, and storage access networking (SAN) cards in the Cisco ONS 15454.

For information about enabling and viewing PM values, refer to the *Cisco ONS 15454 Procedure Guide*.

Chapter topics include:

- [15.1 Threshold Performance Monitoring, page 15-1](#)
- [15.2 Intermediate Path Performance Monitoring, page 15-3](#)
- [15.3 Pointer Justification Count Performance Monitoring, page 15-4](#)
- [15.4 Performance Monitoring Parameter Definitions, page 15-4](#)
- [15.5 Performance Monitoring for Electrical Cards, page 15-12](#)
- [15.6 Performance Monitoring for Ethernet Cards, page 15-29](#)
- [15.7 Performance Monitoring for Optical Cards, page 15-48](#)
- [15.8 Performance Monitoring for Optical Multirate Cards, page 15-51](#)
- [15.9 Performance Monitoring for Storage Access Networking Cards, page 15-52](#)



Note

For transponder (TXP), and muxponder (TXP), and DWDM card PM parameters, refer to the *Cisco ONS 15454 DWDM Reference Manual*.



Note

For additional information regarding PM parameters, refer to Telcordia documents GR-1230-CORE, GR-820-CORE, GR-499-CORE, and GR-253-CORE and the ANSI T1.231 document entitled *Digital Hierarchy - Layer 1 In-Service Digital Transmission Performance Monitoring*.

15.1 Threshold Performance Monitoring

Thresholds are used to set error levels for each PM parameter. You can set individual PM threshold values from the Cisco Transport Controller (CTC) card view Provisioning tab. For procedures on provisioning card thresholds, such as line, path, and SONET thresholds, refer to the *Cisco ONS 15454 Procedure Guide*.

During the accumulation cycle, if the current value of a PM parameter reaches or exceeds its corresponding threshold value, a threshold crossing alert (TCA) is generated by the node and displayed by CTC. TCAs provide early detection of performance degradation. When a threshold is crossed, the node continues to count the errors during a given accumulation period. If zero is entered as the threshold value, generation of TCAs is disabled, but performance monitoring continues.

Change the threshold if the default value does not satisfy your error monitoring needs. For example, customers with a critical DS-1 installed for 911 calls must guarantee the best quality of service on the line; therefore, they lower all thresholds so that the slightest error raises a TCA.

When TCAs occur, they appear in CTC. An example is T-UASP-P in the **Cond** column (shown in Figure 15-1), where the “T-” indicates a threshold crossing. For certain electrical cards, “RX” or “TX” is appended to the TCA description, as indicated by the red circles in Figure 15-1. The RX indicates that the TCA is associated with the receive direction, and TX indicates that the TCA is associated with the transmit direction.

Figure 15-1 TCAs Displayed in CTC

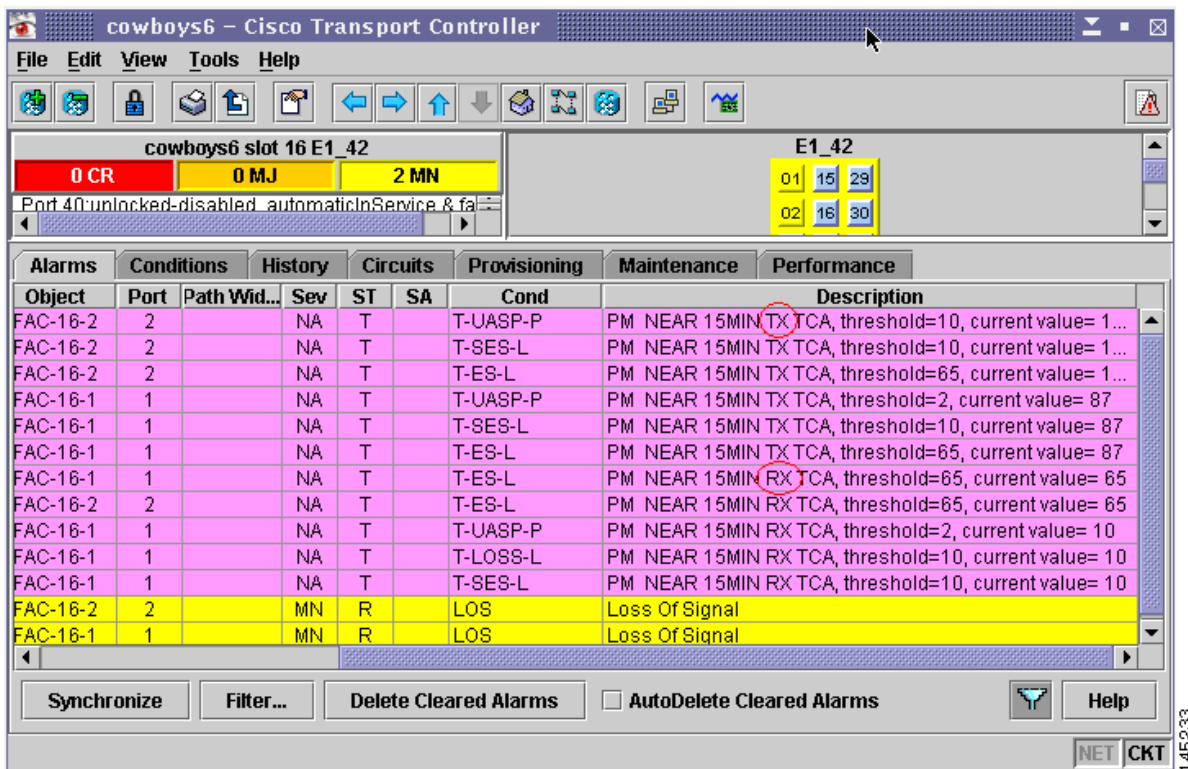

Table 15-1 shows the electrical cards for which RX and TX are appended to the TCA descriptions.

Table 15-1 Electrical Cards that Report RX and TX Direction for TCAs

Card	Line				Path			
	Near End		Far End		Near End		Far End	
	RX	TX	RX	TX	RX	TX	RX	TX
DS1-14	YES	—	YES	—	YES	YES	YES	—
DS1N-14	YES	—	YES	—	YES	YES	YES	—

Due to memory limitations and the number of TCAs generated by different platforms, you can manually add/modify the following two properties to the platform property file (CTC.INI for Windows and .ctcr for UNIX):

- **ctc.15xxx.node.tr.lowater=yyy** where xxx is the platform and yyy is the number of the lowater mark. The default lowater mark is 25.
- **ctc.15xxx.node.tr.hiwater=yyy** where xxx is the platform and yyy is the number of the hiwater mark. The default hiwater mark is 50.

If the number of the incoming TCA is greater than the hiwater mark, the node will keep the latest lowater mark and discard older ones.

15.2 Intermediate Path Performance Monitoring

Intermediate path performance monitoring (IPPM) allows transparent monitoring of a constituent channel of an incoming transmission signal by a node that does not terminate that channel. Many large networks only use line terminating equipment (LTE), not path terminating equipment (PTE). [Table 15-2](#) shows ONS 15454 cards that are considered LTE.

Table 15-2 ONS 15454 Line Terminating Equipment

ONS 15454 Electrical LTE	
EC1-12 card	
ONS 15454 Optical LTE	
OC3 IR 4/STM1 SH 1310	OC3 IR/STM1 SH 1310-8
OC12 IR/STM4 SH1310	OC12 LR/STM4 LH1310
OC12 LR/STM4 LH 1550	OC12 IR/STM4 SH 1310-4
OC48 IR/STM16 SH AS 1310	OC48 LR/STM16 LH AS 1550
OC48 ELR/STM16 EH 100 GHz	OC48 ELR 200 GHz
OC192 SR/STM64 IO 1310	OC192 IR/STM64 SH 1550
OC192 LR/STM64 LH 1550	OC192 LR/STM64 LH ITU 15xx.xx
TXP_MR_10G	MXP_2.5G_10G
MXP_MR_2.5G	MXPP_MR_2.5G
MRC-12	MRC-2.5G-4
OC 192 - XFP	

ONS 15454 Software R3.0 and higher allows LTE cards to monitor near-end PM data on individual synchronous transport signal (STS) payloads by enabling IPPM. After enabling IPPM provisioning on the line card, service providers can monitor large amounts of STS traffic through intermediate nodes, thus making troubleshooting and maintenance activities more efficient.

IPPM occurs only on STS paths that have IPPM enabled, and TCAs are raised only for PM parameters on the IPPM enabled paths. The monitored IPPM parameters are STS CV-P, STS ES-P, STS SES-P, STS UAS-P, and STS FC-P.

**Note**

Far-end IPPM is not supported by all OC-N cards. It is supported by OC3-4 and EC-1 cards. However, SONET path PMs can be monitored by logging into the far-end node directly.

The ONS 15454 performs IPPM by examining the overhead in the monitored path and by reading all of the near-end path PM values in the incoming direction of transmission. The IPPM process allows the path signal to pass bidirectionally through the node completely unaltered.

See [Table 15-3 on page 15-5](#) for detailed information and definitions of specific IPPM parameters.

15.3 Pointer Justification Count Performance Monitoring

Pointers are used to compensate for frequency and phase variations. Pointer justification counts indicate timing errors on SONET networks. When a network is out of synchronization, jitter and wander occur on the transported signal. Excessive wander can cause terminating equipment to slip.

Slips cause different effects in service. Voice service has intermittent audible clicks. Compressed voice technology has short transmission errors or dropped calls. Fax machines lose scanned lines or experience dropped calls. Digital video transmission has distorted pictures or frozen frames. Encryption service loses the encryption key, causing data to be transmitted again.

Pointers provide a way to align the phase variations in STS and VT payloads. The STS payload pointer is located in the H1 and H2 bytes of the line overhead. Clocking differences are measured by the offset in bytes from the pointer to the first byte of the STS synchronous payload envelope (SPE) called the J1 byte. Clocking differences that exceed the normal range of 0 to 782 can cause data loss.

There are positive (PPJC) and negative (NPJC) pointer justification count parameters. PPJC is a count of path-detected (PPJC-PDET-P) or path-generated (PPJC-PGEN-P) positive pointer justifications. NPJC is a count of path-detected (NPJC-PDET-P) or path-generated (NPJC-PGEN-P) negative pointer justifications depending on the specific PM name. PJCDIFF is the absolute value of the difference between the total number of detected pointer justification counts and the total number of generated pointer justification counts. PJCS-PDET-P is a count of the one-second intervals containing one or more PPJC-PDET or NPJC-PDET. PJCS-PGEN-P is a count of the one-second intervals containing one or more PPJC-PGEN or NPJC-PGEN.

A consistent pointer justification count indicates clock synchronization problems between nodes. A difference between the counts means that the node transmitting the original pointer justification has timing variations with the node detecting and transmitting this count. Positive pointer adjustments occur when the frame rate of the SPE is too slow in relation to the rate of the STS-1.

You must enable PPJC and NPJC performance monitoring parameters for LTE cards. See [Table 15-2 on page 15-3](#) for a list of Cisco ONS 15454 LTE cards. In CTC, the count fields for PPJC and NPJC PMs appear white and blank unless they are enabled on the card view Provisioning tab.

See [Table 15-3 on page 15-5](#) for detailed information and definitions of specific pointer justification count PM parameters.

15.4 Performance Monitoring Parameter Definitions

[Table 15-3](#) gives definitions for each type of PM parameter found in this chapter.

Table 15-3 Performance Monitoring Parameters

Parameter	Definition
AISS-P	AIS Seconds Path (AISS-P) is a count of one-second intervals containing one or more alarm indication signal (AIS) defects.
BBE-PM	Path Monitoring Background Block Errors (BBE-PM) indicates the number of background block errors recorded in the optical transport network (OTN) path during the PM time interval.
BBE-SM	Section Monitoring Background Block Errors (BBE-SM) indicates the number of background block errors recorded in the OTN section during the PM time interval.
BBER-PM	Path Monitoring Background Block Errors Ratio (BBER-PM) indicates the background block errors ratio recorded in the OTN path during the PM time interval.
BBER-SM	Section Monitoring Background Block Errors Ratio (BBER-SM) indicates the background block errors ratio recorded in the OTN section during the PM time interval.
BIT-EC	Bit Errors Corrected (BIT-EC) indicated the number of bit errors corrected in the DWDM trunk line during the PM time interval.
CSS	Controlled Slip Seconds (CSS) indicates the count of the seconds when at least one or more controlled slips have occurred.
CSS-P	Controlled Slip Seconds Path (CSS-P) indicates the count of the seconds when at least one or more controlled slips have occurred.
CVCP-P	Code Violation CP-bit Path (CVCP-P) is a count of CP-bit parity errors occurring in the accumulation period.
CVCP-PFE	Code Violation CP-bit Path (CVCP-PFE) is a parameter that is counted when the three far-end block error (FEBE) bits in an M-frame are not all collectively set to 1.
CGV	Code Group Violations (CGV) is a count of received code groups that do not contain a start or end delimiter.
CV-L	Line Code Violation (CV-L) indicates the number of coding violations occurring on the line. This parameter is a count of bipolar violations (BPVs) and excessive zeros (EXZs) occurring over the accumulation period.
CV-P	Near-End STS Path Coding Violations (CV-P) is a count of BIP errors detected at the STS path layer (that is, using the B3 byte). Up to eight BIP errors can be detected per frame; each error increments the current CV-P second register.
CV-PFE	Far-End STS Path Coding Violations (CV-PFE) is a count of BIP errors detected at the STS path layer (that is, using the B3 byte). Up to eight BIP errors can be detected per frame; each error increments the current CV-PFE second register.
CVP-P	Code Violation Path (CVP-P) is a code violation parameter for M23 applications. CVP-P is a count of P-bit parity errors occurring in the accumulation period.

Table 15-3 Performance Monitoring Parameters (continued)

Parameter	Definition
CV-S	Section Coding Violation (CV-S) is a count of bit interleaved parity (BIP) errors detected at the section layer (that is, using the B1 byte in the incoming SONET signal). Up to eight section BIP errors can be detected per STS-N frame; each error increments the current CV-S second register.
CV-V	Code Violation VT Layer (CV-V) is a count of the BIP errors detected at the VT path layer. Up to two BIP errors can be detected per VT superframe, with each error incrementing the current CV-V second register.
DCG	Data Code Groups (DCG) is a count of received data code groups that do not contain ordered sets.
ESA-P	Path Errored Seconds-A (ESA-P) is the count of 1-second intervals with exactly one CRC-6 error and no AIS or severely errored framing (SEF) defects.
ESB-P	Path Errored Seconds-B (Rx ESB-P) is a count of 1-second intervals with between 2 and 319 CRC-6 errors and no AIS or SEF.
ESCP-P	Errored Seconds CP-bit Path (ESCP-P) is a count of seconds containing one or more CP-bit parity errors, one or more SEF defects, or one or more AIS defects. ESCP-P is defined for the C-bit parity application.
ESCP-PFE	Far-End Errored Seconds CP-bit Path (ESCP-PFE) is a count of one-second intervals containing one or more M-frames with the three FEBE bits not all collectively set to 1 or one or more far-end SEF/AIS defects.
ES-L	Line Errored Seconds (ES-L) is a count of the seconds containing one or more anomalies (BPV + EXZ) and/or defects (that is, loss of signal) on the line.
ES-NP	
ES-P	Near-End STS Path Errored Seconds (ES-P) is a count of the seconds when at least one STS path BIP error was detected. An AIS Path (AIS-P) defect (or a lower-layer, traffic-related, near-end defect) or a Loss of Pointer Path (LOP-P) defect can also cause an ES-P.
ES-PFE	Far-End STS Path Errored Seconds (ES-PFE) is a count of the seconds when at least one STS path BIP error was detected. An AIS-P defect (or a lower-layer, traffic-related, far-end defect) or an LOP-P defect can also cause an STS ES-PFE.
ES-PM	Path Monitoring Errored Seconds (ES-PM) indicates the errored seconds recorded in the OTN path during the PM time interval.
ESP-P	Errored Seconds Path (ESP-P) is a count of seconds containing one or more P-bit parity errors, one or more SEF defects, or one or more AIS defects.
ESR-PM	Path Monitoring Errored Seconds Ratio (ESR-PM) indicates the errored seconds ratio recorded in the OTN path during the PM time interval.
ESR-SM	Section Monitoring Errored Seconds Ratio (ESR-SM) indicates the errored seconds ratio recorded in the OTN section during the PM time interval.

Table 15-3 Performance Monitoring Parameters (continued)

Parameter	Definition
ES-S	Section Errored Seconds (ES-S) is a count of the number of seconds when at least one section-layer BIP error was detected or an SEF or loss of signal (LOS) defect was present.
ES-SM	Section Monitoring Errored Seconds (ES-SM) indicates the errored seconds recorded in the OTN section during the PM time interval.
ES-V	Errored Seconds VT Layer (ES-V) is a count of the seconds when at least one VT Path BIP error was detected. An AIS Virtual Tributary (VT) (AIS-V) defect (or a lower-layer, traffic-related, near-end defect) or an LOP VT (LOP-V) defect can also cause an ES-V.
FC-L	Line Failure Count (FC-L) is a count of the number of near-end line failure events. A failure event begins when an AIS Line (AIS-L) failure is declared or when a lower-layer, traffic-related, near-end failure is declared. This failure event ends when the failure is cleared. A failure event that begins in one period and ends in another period is counted only in the period where it begins.
FC-P	Near-End STS Path Failure Counts (FC-P) is a count of the number of near-end STS path failure events. A failure event begins when an AIS-P failure, an LOP-P failure, a UNEQ-P failure, or a Section Trace Identifier Mismatch Path (TIM-P) failure is declared. A failure event also begins if the STS PTE that is monitoring the path supports Three-Bit (Enhanced) Remote Failure Indication Path Connectivity (ERFI-P-CONN) for that path. The failure event ends when these failures are cleared.
FC-PFE	Far-End STS Path Failure Counts (FC-PFE) is a count of the number of near-end STS path failure events. A failure event begins when an AIS-P failure, an LOP-P failure, a UNEQ-P failure, or a TIM-P failure is declared. A failure event also begins if the STS PTE that is monitoring the path supports ERFI-P-CONN for that path. The failure event ends when these failures are cleared.
FC-PM	Path Monitoring Failure Counts (FC-PM) indicates the failure counts recorded in the OTN path during the PM time interval.
FC-SM	Section Monitoring Failure Counts (FC-SM) indicates the failure counts recorded in the OTN section during the PM time interval.
IOS	Idle Ordered Sets (IOS) is a count of received packets containing idle ordered sets.
IPC	Invalid Packets (IPC) is the count of received packets that contain errored data code groups that have start and end delimiters.
LBCL-MIN	Laser Bias Current Line—Minimum (LBCL-MIN) is the minimum percentage of laser bias current.
LBCL-AVG	Laser Bias Current Line—Average (LBCL-AVG) is the average percentage of laser bias current.
LBCL-MAX	Laser Bias Current Line—Maximum (LBCL-MAX) is the maximum percentage of laser bias current.
LOFC	Loss of Frame Count (LOFC)

Table 15-3 Performance Monitoring Parameters (continued)

Parameter	Definition
LOSS-L	Line Loss of Signal (LOSS-L) is a count of one-second intervals containing one or more LOS defects.
NIOS	Non-Idle Ordered Sets (NIOS) is a count of received packets containing non-idle ordered sets.
NPJC-PDET	Negative Pointer Justification Count, STS Detected (NPJC-PDET), formerly Pointer Justification Negative (PJNEG)
NPJC-PDET-P	Negative Pointer Justification Count, STS Path Detected (NPJC-PDET-P) is a count of the negative pointer justifications detected on a particular path in an incoming SONET signal.
NPJC-PGEN-P	Negative Pointer Justification Count, STS Path Generated (NPJC-PGEN-P) is a count of the negative pointer justifications generated for a particular path to reconcile the frequency of the SPE with the local clock.
OPR	Optical Power Received (OPR) is the measure of average optical power received as a percentage of the nominal OPR.
OPR-AVG	Average Receive Optical Power (dBm)
OPR-MAX	Maximum Receive Optical Power (dBm)
OPR-MIN	Minimum Receive Optical Power (dBm)
OPT	Optical Power Transmitted (OPT) is the measure of average optical power transmitted as a percentage of the nominal OPT.
OPT-AVG	Average Transmit Optical Power (dBm)
OPT-MAX	Maximum Transmit Optical Power (dBm)
OPT-MIN	Minimum Transmit Optical Power (dBm)
OPWR-AVG	Optical Power - Average (OPWR-AVG) is the measure of average optical power on the unidirectional port.
OPWR-MAX	Optical Power - Maximum (OPWR-MAX) is the measure of maximum value of optical power on the unidirectional port.
OPWR-MIN	Optical Power - Minimum (OPWR-MIN) is the measure of minimum value of optical power on the unidirectional port.
PJCDIFF-P	Pointer Justification Count Difference, STS Path (PJCDIFF-P) is the absolute value of the difference between the total number of detected pointer justification counts and the total number of generated pointer justification counts. That is, PJCDiff-P is equal to (PPJC-PGEN-P – NPJC-PGEN-P) – (PPJC-PDET-P – NPJC-PDET-P).
PPJC-PDET	Pointer Justification STS Detected (PPJC-PDET), formerly Pointer Justification Positive (PJPOS).
PPJC-PDET-P	Positive Pointer Justification Count, STS Path Detected (PPJC-PDET-P) is a count of the positive pointer justifications detected on a particular path in an incoming SONET signal.
PPJC-PGEN-P	Positive Pointer Justification Count, STS Path Generated (PPJC-PGEN-P) is a count of the positive pointer justifications generated for a particular path to reconcile the frequency of the SPE with the local clock.

Table 15-3 Performance Monitoring Parameters (continued)

Parameter	Definition
PJCS-PDET-P	Pointer Justification Count Seconds, STS Path Detect (NPJCS-PDET-P) is a count of the one-second intervals containing one or more PPJC-PDET or NPJC-PDET.
PJCS-PGEN-P	Pointer Justification Count Seconds, STS Path Generate (PJCS-PGEN-P) is a count of the one-second intervals containing one or more PPJC-PGEN or NPJC-PGEN.
PSC	In a 1 + 1 protection scheme for a working card, Protection Switching Count (PSC) is a count of the number of times service switches from a working card to a protection card plus the number of times service switches back to the working card. For a protection card, PSC is a count of the number of times service switches to a working card from a protection card plus the number of times service switches back to the protection card. The PSC PM parameter is only applicable if revertive line-level protection switching is used.
PSC-R	In a four-fiber bidirectional line switched ring (BLSR), Protection Switching Count-Ring (PSC-R) is a count of the number of times service switches from a working line to a protection line plus the number of times it switches back to a working line. A count is only incremented if ring switching is used.
PSC-S	In a four-fiber BLSR, Protection Switching Count-Span (PSC-S) is a count of the number of times service switches from a working line to a protection line plus the number of times it switches back to the working line. A count is only incremented if span switching is used.
PSC-W	For a working line in a two-fiber BLSR, Protection Switching Count-Working (PSC-W) is a count of the number of times traffic switches away from the working capacity in the failed line and back to the working capacity after the failure is cleared. PSC-W increments on the failed working line and PSC increments on the active protect line. For a working line in a four-fiber BLSR, PSC-W is a count of the number of times service switches from a working line to a protection line plus the number of times it switches back to the working line. PSC-W increments on the failed line and PSC-R or PSC-S increments on the active protect line.
PSD	Protection Switching Duration (PSD) applies to the length of time, in seconds, that service is carried on another line. For a working line, PSD is a count of the number of seconds that service was carried on the protection line. For the protection line, PSD is a count of the seconds that the line was used to carry service. The PSD PM is only applicable if revertive line-level protection switching is used.
PSD-R	In a four-fiber BLSR, Protection Switching Duration-Ring (PSD-R) is a count of the seconds that the protection line was used to carry service. A count is only incremented if ring switching is used.

Table 15-3 Performance Monitoring Parameters (continued)

Parameter	Definition
PSD-S	In a four-fiber BLSR, Protection Switching Duration-Span (PSD-S) is a count of the seconds that the protection line was used to carry service. A count is only incremented if span switching is used.
SASCP-P	SEF/AIS Seconds CP-bit Path (SASCP-P) is a count of one-second intervals containing one or more SEFs or one or more AIS defects on the path.
SASP	SEF/AIS Seconds (SASP) is a count of one-second intervals containing one or more SEFs or one or more AIS defects on the path.
SASP-P	SEF/AIS Seconds Path (SASP-P) is a count of one-second intervals containing one or more SEFs or one or more AIS defects on the path.
SEF-S	Severely Errored Framing Seconds (SEFS-S) is a count of the seconds when an SEF defect was present. An SEF defect is expected to be present during most seconds when an LOS or loss of frame (LOF) defect is present. However, there can be situations when the SEFS-S parameter is only incremented based on the presence of the SEF defect.
SESCP-P	Severely Errored Seconds CP-bit Path (SESCP-P) is a count of seconds containing more than 44 CP-bit parity errors, one or more SEF defects, or one or more AIS defects.
SESCP-PFE	Severely Errored Seconds CP-bit Path (SESCP-PFE) is a count of one-second intervals containing one or more far-end SEF/AIS defects, or one or more 44 M-frames with the three FEBE bits not all collectively set to 1.
SES-L	Line Severely Errored Seconds (SES-L) is a count of the seconds containing more than a particular quantity of anomalies ($BPV + EXZ \geq 44$) and/or defects on the line.
SES-P	Near-End STS Path Severely Errored Seconds (SES-P) is a count of the seconds when K (2400) or more STS path BIP errors were detected. An AIS-P defect (or a lower-layer, traffic-related, near-end defect) or an LOP-P defect can also cause an SES-P.
SES-PFE	Far-End STS Path Severely Errored Seconds (SES-PFE) is a count of the seconds when K (2400) or more STS path BIP errors were detected. An AIS-P defect (or a lower-layer, traffic-related, far-end defect) or an LOP-P defect can also cause an SES-PFE.
SES-PM	Path Monitoring Severely Errored Seconds (SES-PM) indicates the severely errored seconds recorded in the OTN path during the PM time interval.
SESP-P	Severely Errored Seconds Path (SESP-P) is a count of seconds containing more than 44 P-bit parity violations, one or more SEF defects, or one or more AIS defects.
SES-S	Section Severely Errored Seconds (SES-S) is a count of the seconds when K (see Telcordia GR-253 for value) or more section-layer BIP errors were detected or an SEF or LOS defect was present.
SES-SM	Section Monitoring Severely Errored Seconds (SES-SM) indicates the severely errored seconds recorded in the OTN section during the PM time interval.

Table 15-3 Performance Monitoring Parameters (continued)

Parameter	Definition
SESR-PM	Path Monitoring Severely Errored Seconds Ratio (SESR-PM) indicates the severely errored seconds ratio recorded in the OTN path during the PM time interval.
SESR-SM	Section Monitoring Severely Errored Seconds Ratio (SESR-SM) indicates the severely errored seconds ratio recorded in the OTN section during the PM time interval.
SES-V	Severely Errored Seconds VT Layer (SES-V) is a count of seconds when K (600) or more VT Path BIP errors were detected. An AIS-V defect (or a lower-layer, traffic-related, near-end defect) or an LOP-V defect can also cause SES-V.
UAS-L	Line Unavailable Seconds (UAS-L) is a count of the seconds when the line is unavailable. A line becomes unavailable when ten consecutive seconds occur that qualify as SES-Ls, and it continues to be unavailable until ten consecutive seconds occur that do not qualify as SES-Ls.
UASCP-P	Unavailable Seconds CP-bit Path (UASCP-P) is a count of one-second intervals when the DS-3 path is unavailable. A DS-3 path becomes unavailable when ten consecutive SESCO-Ps occur. The ten SESCO-Ps are included in unavailable time. After the DS-3 path becomes unavailable, it becomes available again when ten consecutive seconds with no SESCO-Ps occur. The ten seconds with no SESCO-Ps are excluded from unavailable time.
UASCP-PFE	Unavailable Seconds CP-bit Path (UASCP-PFE) is a count of one-second intervals when the DS-3 path becomes unavailable. A DS-3 path becomes unavailable when ten consecutive far-end CP-bit SESs occur. The ten CP-bit SESs are included in unavailable time. After the DS-3 path becomes unavailable, it becomes available again when ten consecutive seconds occur with no CP-bit SESs. The ten seconds with no CP-bit SESs are excluded from unavailable time.
UAS-P	Near-End STS Path Unavailable Seconds (UAS-P) is a count of the seconds when the STS path was unavailable. An STS path becomes unavailable when ten consecutive seconds occur that qualify as SES-Ps, and continues to be unavailable until ten consecutive seconds occur that do not qualify as SES-Ps.
UAS-PFE	Far-End STS Path Unavailable Seconds (UAS-PFE) is a count of the seconds when the STS path was unavailable. An STS path becomes unavailable when ten consecutive seconds occur that qualify as SES-PFEs, and continues to be unavailable until ten consecutive seconds occur that do not qualify as SES-PFEs.
UAS-PM	Path Monitoring Unavailable Seconds (UAS-PM) indicates the unavailable seconds recorded in the OTN path during the PM time interval.

Table 15-3 Performance Monitoring Parameters (continued)

Parameter	Definition
UASP-P	Unavailable Seconds Path (UASP-P) is a count of one-second intervals when the DS-3 path is unavailable. A DS-3 path becomes unavailable when ten consecutive SESP-Ps occur. The ten SESP-Ps are included in unavailable time. After the DS-3 path becomes unavailable, it becomes available again when ten consecutive seconds with no SESP-Ps occur. The ten seconds with no SESP-Ps are excluded from unavailable time.
UAS-SM	Section Monitoring Unavailable Seconds (UAS-SM) indicates the unavailable seconds recorded in the OTN section during the PM time interval.
UAS-V	Unavailable Seconds VT Layer (UAS-V) is a count of the seconds when the VT path was unavailable. A VT path becomes unavailable when ten consecutive seconds occur that qualify as SES-Vs, and it continues to be unavailable until ten consecutive seconds occur that do not qualify as SES-Vs.
UNC-WORDS	Uncorrectable Words (UNC-WORDS) is the number of uncorrectable words detected in the DWDM trunk line during the PM time interval.
VPC	Valid Packets (VPC) is a count of received packets that contain non-errored data code groups that have start and end delimiters.

15.5 Performance Monitoring for Electrical Cards

The following sections define PM parameters for the EC1-12, DS1/E1-56, DS1-14, DS1N-14, DS3-12, DS3-12E, DS3N-12, DS3N-12E, DS3i-N-12, DS3XM-6, DS3XM-12, and DS3/EC1-48 cards.

15.5.1 EC1-12 Card Performance Monitoring Parameters

Figure 15-2 shows signal types that support near-end and far-end PMs. Figure 15-3 shows where overhead bytes detected on the application specific integrated circuits (ASICs) produce PM parameters for the EC1-12 card.

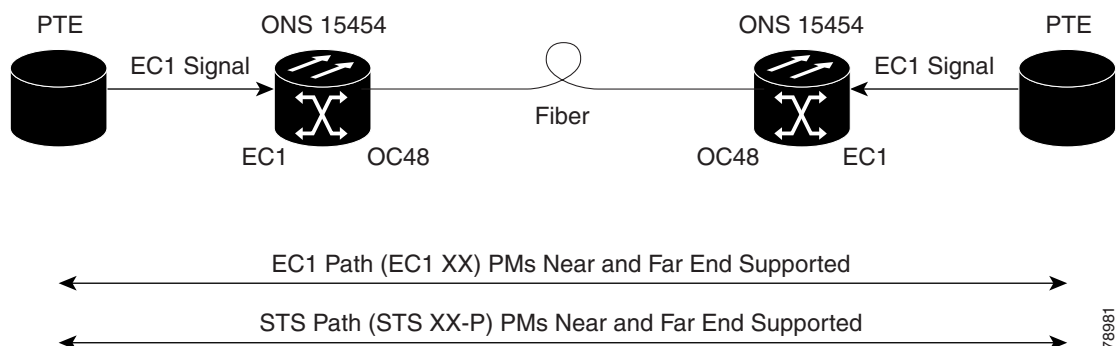
Figure 15-2 Monitored Signal Types for the EC1-12 Card

 **Note**

The XX in Figure 15-2 represents all PMs listed in Table 15-4 with the given prefix and/or suffix.

Figure 15-3 PM Read Points on the EC1-12 Card

ONS 15454

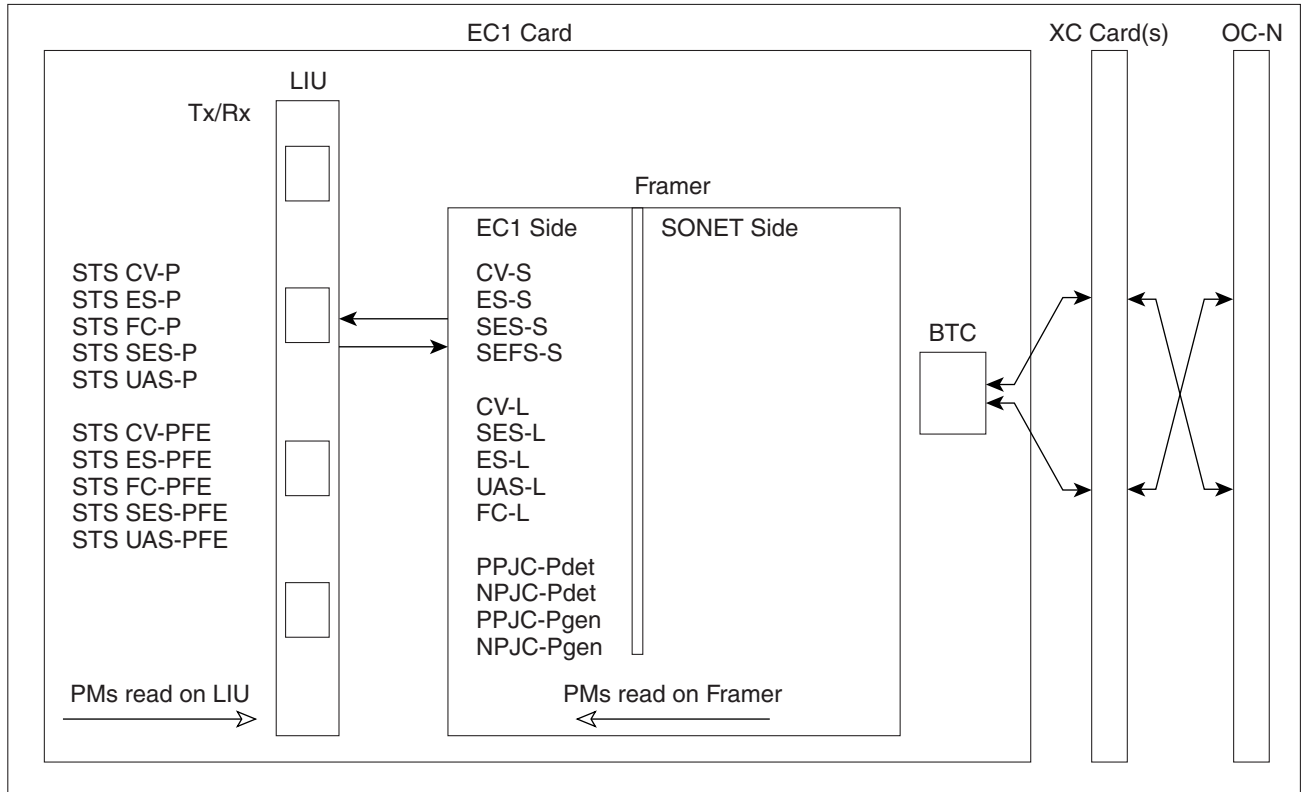

78982

Table 15-4 lists the PM parameters for the EC1-12 cards.

Table 15-4 EC1-12 Card PMs

Section (NE)	Line (NE)	STS Path (NE)	Line (FE)	STS Path (FE)
CV-S	CV-L	CV-P	CV-LFE	CV-PFE
ES-S	ES-L	ES-P	ES-LFE	ES-PFE
SES-S	SES-L	SES-P	SES-LFE	SES-PFE
SEF-S	UAS-L	UAS-P	UAS-LFE	UAS-PFE
	FC-L	FC-P	FC-LFE	FC-PFE
		PPJC-PDET-P		
		NPJC-PDET-P		
		PPJC-PGEN-P		
		NPJC-PGEN-P		
		PJCS-PDET-P		
		PJCS-PGEN-P		
		PJC-DIFF-P		

**Note**

If the CV-L(NE and FE) falls in the range 51-61 for EC1, then, the user might see discrepancy in the SES and the UAS-L values. However, ES-L will be in the nearest accuracy. For a few seconds, in a given 10 seconds interval, the number of CV-L counted may not cross the CV count criteria for SES, (due to system/application limitation for the below mentioned ranges); as a consequence of which there may not be 10 continuous SES, thus UAS will not be observed.

15.5.2 DS1/E1-56 Card Performance Monitoring Parameters

Figure 15-4 shows signal types that support near-end and far-end PMs.

Figure 15-4 Monitored Signal Types for the DS1/E1-56 Card

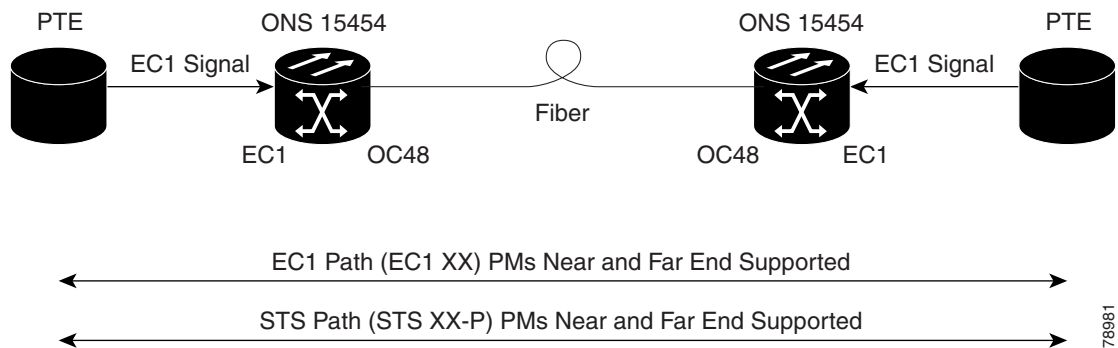

Figure 15-5 shows where overhead bytes detected on the ASICs produce PM parameters for the DS1/E1-56 card.

Figure 15-5 PM Read Points on the DS1/E1-56 Card

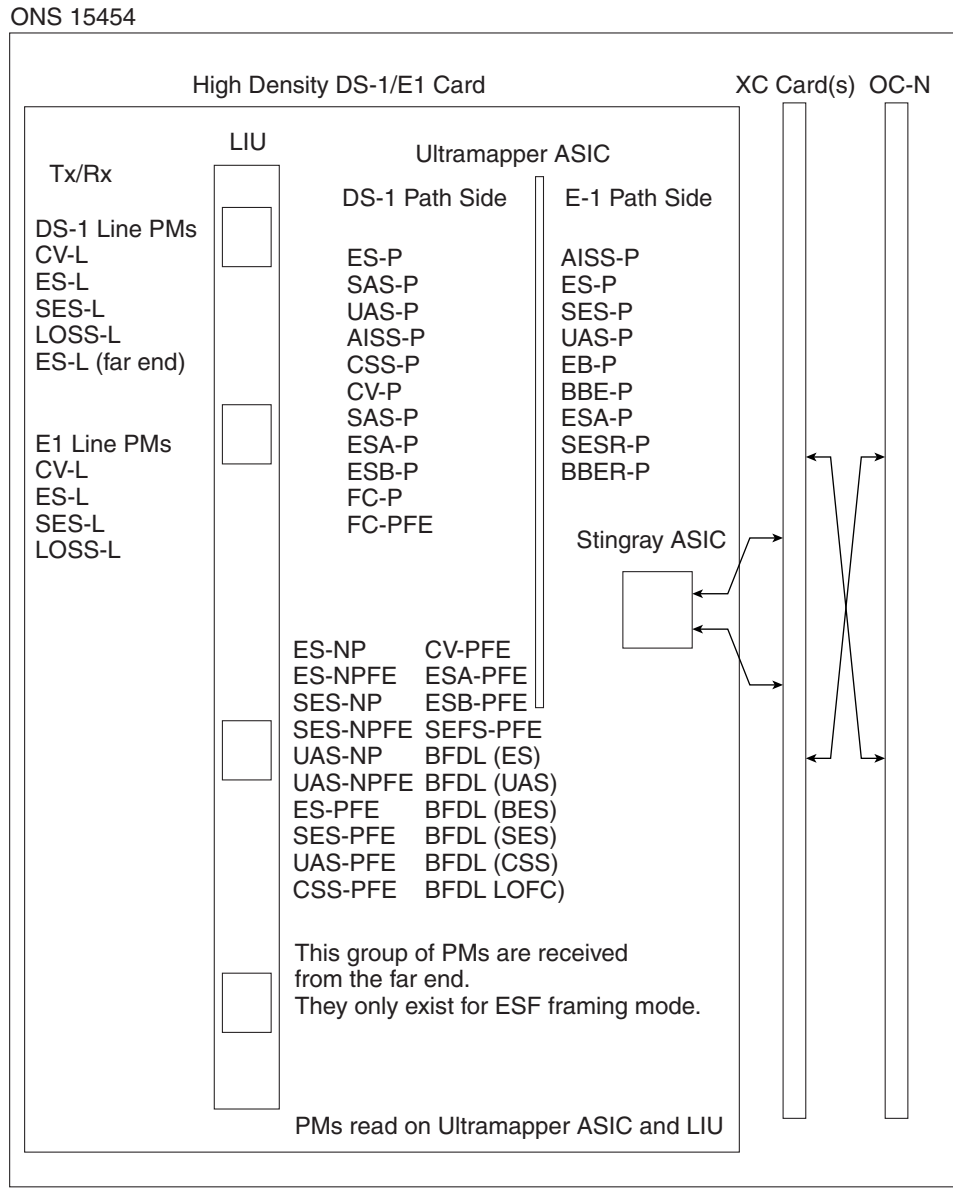

Table 15-5 lists the PM parameters for the DS1/E1-56 card.

Table 15-5 DS1/E1-56 Card PMs

Line (NE)	Line (FE)	Rx Path (NE)	Tx Path (NE)	STS Path (NE)	Rx Path (FE)	STS Path (FE)	Network Path	BFDL (FE)
CV-L	CV-L	AISS-P	AISS-P	CV-P	ES-PFE	CV-PFE	ES-NP	CSS
ES-L	ES-L	CV-P	CV-P	ES-P	ESA-PFE	ES-PFE	ES-NPFE	ES
SES-L	SES-L	ES-P	ES-P	SES-P	ESB-PFE	SES-PFE	SES-NP	SES
LOSS-L	LOSS-L	SES-P	SES-P	UAS-P	CV-PFE	UAS-PFE	SES-NPFE	BES
		SAS-P	UAS-P	FC-P	CSS-PFE	FC-PFE	UAS-NP	UAS
		UAS-P	BBER-P		SEFS-PFE		UAS-NPFE	LOFC
		CSS-P	SESR-P		SES-PFE			
		ESA-P	ESR-P		UAS-PFE			
		ESB-P						
		SEFS-P						

15.5.3 DS1-14 and DS1N-14 Card Performance Monitoring Parameters

Figure 15-6 shows the signal types that support near-end and far-end PMs.

Figure 15-6 Monitored Signal Types for the DS1-14 and DS1N-14 Cards

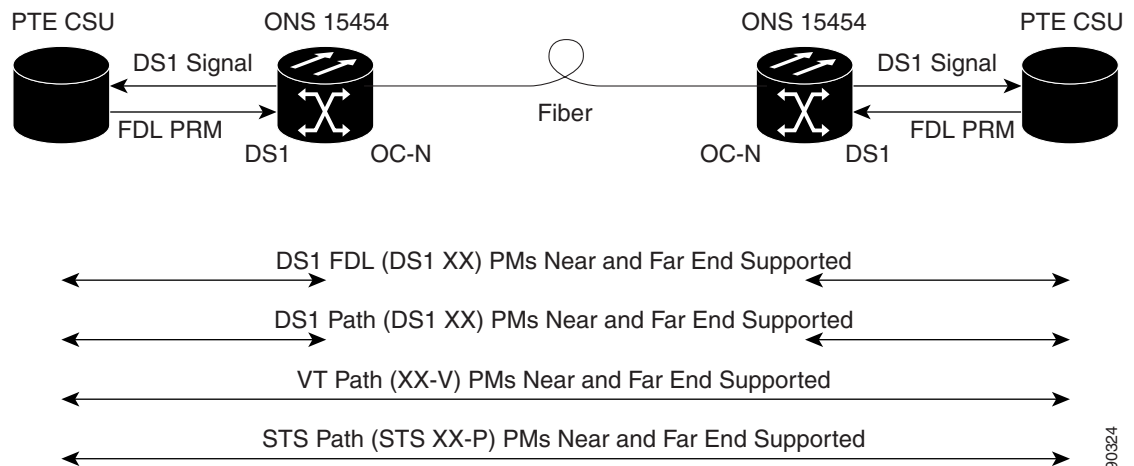

Note

The XX in Figure 15-6 represents all PMs listed in Table 15-6 with the given prefix and/or suffix.

Figure 15-7 shows where overhead bytes detected on the ASICs produce PM parameters for the DS1-14 and DS1N-14 cards.

Figure 15-7 PM Read Points on the DS1-14 and DS1N-14 Cards

ONS 15454

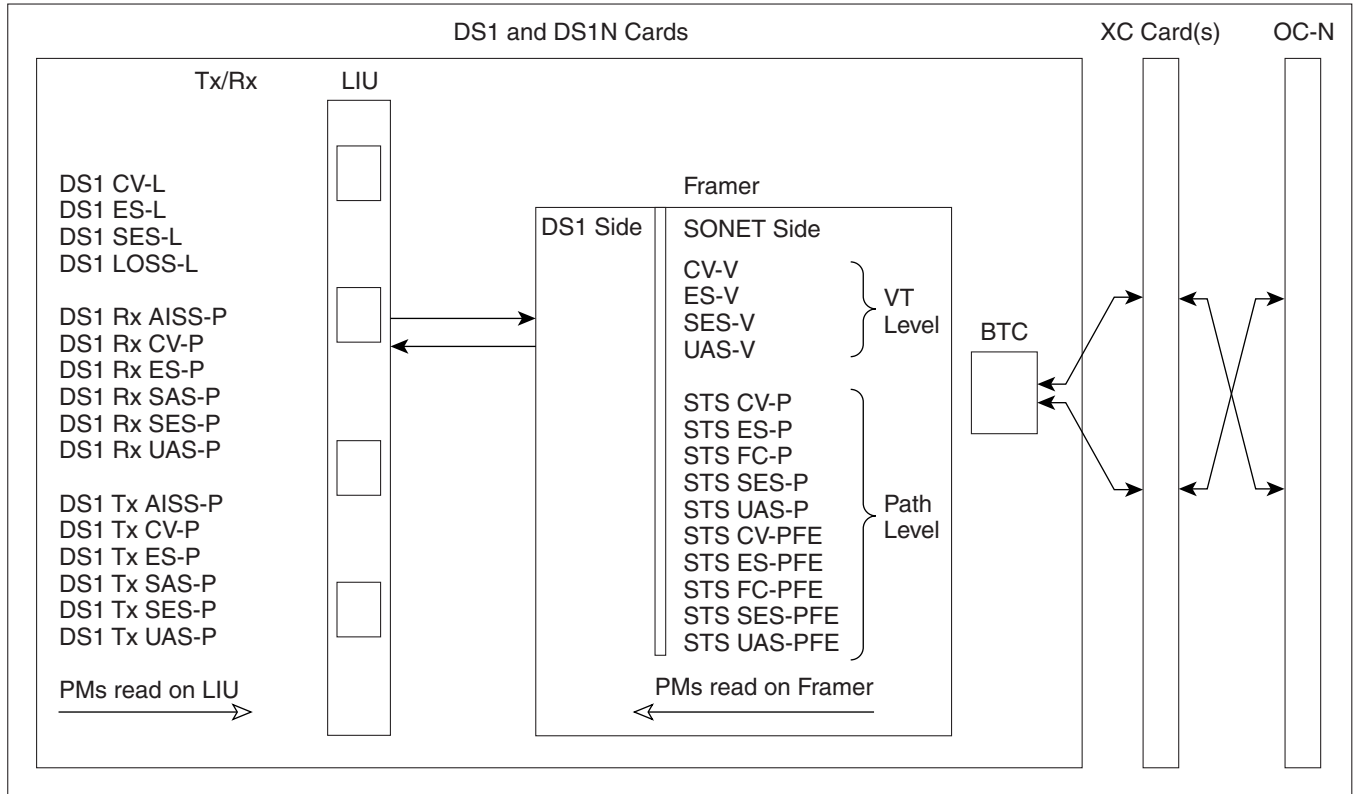

Table 15-6 describes the PM parameters for the DS1-14 and DS1N-14 cards.

Table 15-6 DS1-14 and DS1N-14 Card PMs

Line (NE)	Line (FE)	Rx Path (NE)	Tx Path (NE)	VT Path (NE)	STS Path (NE)	Rx Path (FE)	VT Path (FE)	STS Path (FE)
CV-L	CV-L	AISS-P	AISS-P	CV-V	CV-P	ES-PFE	CV-VFE	CV-PFE
ES-L	ES-L	CV-P	CV-P	ES-V	ES-P	ESA-PFE	ES-VFE	ES-PFE
SES-L		ES-P	ES-P	SES-V	SES-P	ES-B-PFE	SES-VFE	SES-PFE
LOSS-L		FC-P	FC-P	UAS-V	UAS-P	CV-PFE	UAS-VFE	UAS-PFE
		SAS-P	SAS-P	FC-V	FC-P	CSS-PFE	FC-VFE	FC-PFE
		SES-P	SES-P			SEFS-PFE		
		UAS-P	UAS-P			SES-PFE		
		CSS-P				UAS-PFE		
		ESA-P						
		ESB-P						
		SEFS-P						



Note

Far-end DS1 performance monitoring values are valid only when the DS1 line is set to extended super frame (ESF).

15.5.3.1 DS-1 Facility Data Link Performance Monitoring

Facility Data Link (FDL) performance monitoring enables an ONS 15454 DS1N-14 card to calculate and report DS-1 error rate performance measured at both the near-end and far-end of the FDL. The far-end information is reported as received on the FDL in a performance report message (PRM) from an intelligent channel service unit (CSU).

To monitor DS-1 FDL PM values, the DS-1 must be set to use ESF format and the FDL must be connected to an intelligent CSU. For procedures for provisioning ESF on the DS1N-14 card, refer to the *Cisco ONS 15454 Procedure Guide*.

The monitored DS-1 FDL PM parameters are CV-PFE, ES-PFE, ESA-PFE, ESB-PFE, SES-PFE, SEFS-PFE, CSS-PFE, UAS-PFE, FC-PFE, and ES-LFE. See [Table 15-3 on page 15-5](#) for detailed information and definitions of specific FDL DS1 PM parameters.

15.5.4 DS3-12 and DS3N-12 Card Performance Monitoring Parameters

Figure 15-8 shows the signal types that support near-end and far-end PMs. [Figure 15-9](#) shows where overhead bytes detected on the ASICs produce PM parameters for the DS3-12 and DS3N-12 cards.

Figure 15-8 Monitored Signal Types for the DS3-12 and DS3N-12 Cards

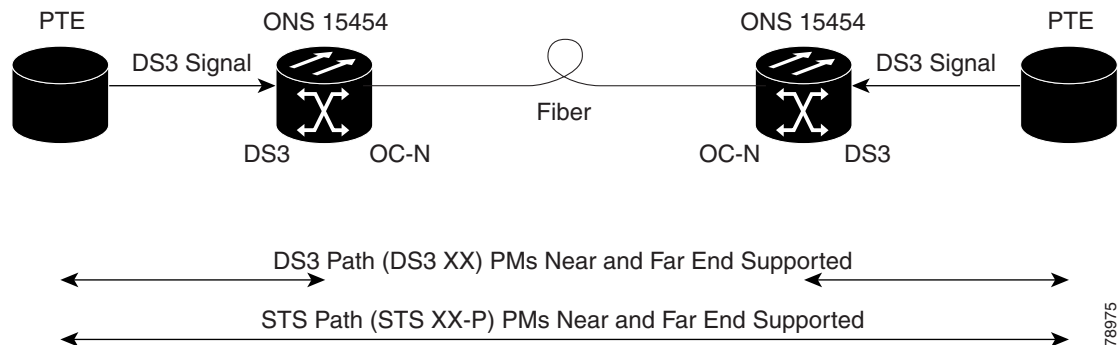

Note

The XX in Figure 15-8 represents all PMs listed in [Table 15-7](#) with the given prefix and/or suffix.

Figure 15-9 PM Read Points on the DS3-12 and DS3N-12 Cards

ONS 15454

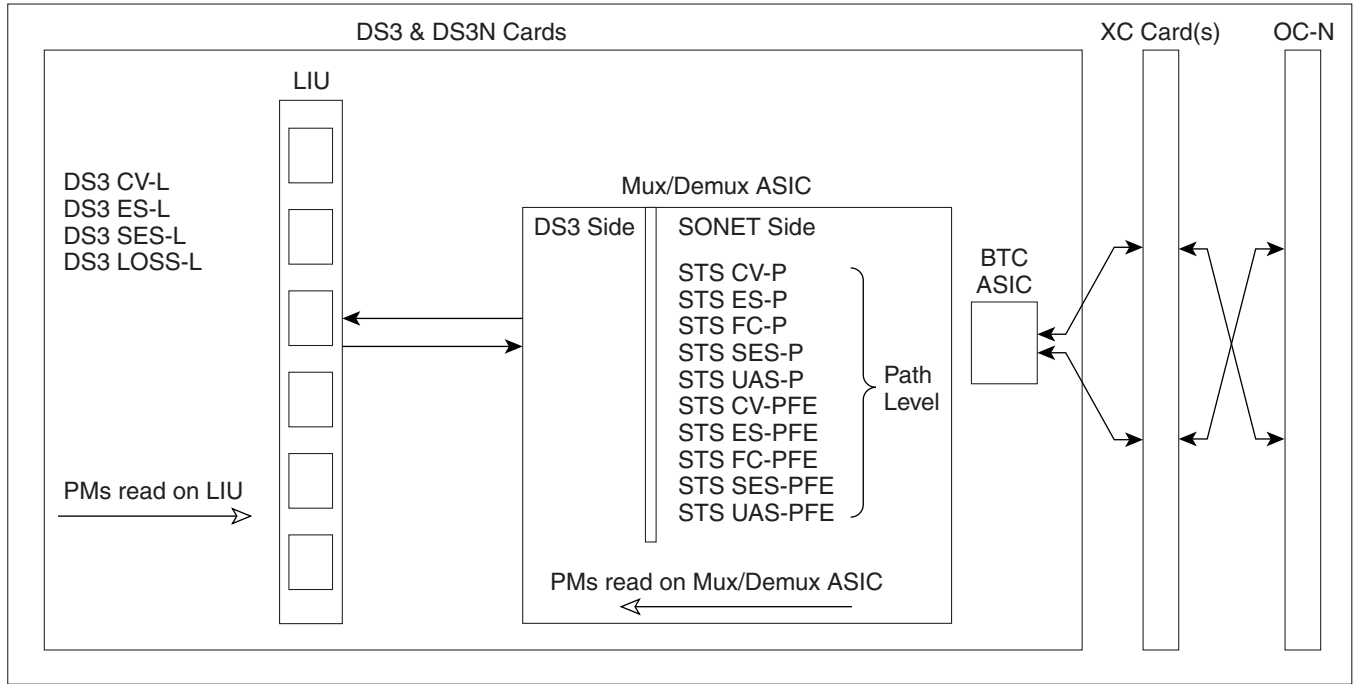

The PM parameters for the DS3-12 and DS3N-12 cards are described in [Table 15-7](#).

Table 15-7 DS3-12 and DS3N-12 Card PMs

Line (NE)	STS Path (NE)	STS Path (FE)
CV-L	CV-P	CV-PFE
ES-L	ES-P	ES-PFE
SES-L	SES-P	SES-PFE
LOSS-L	UAS-P	UAS-PFE
	FC-P	FC-PFE

15.5.5 DS3-12E and DS3N-12E Card Performance Monitoring Parameters

Figure 15-10 shows the signal types that support near-end and far-end PMs.

Figure 15-10 Monitored Signal Types for the DS3-12E and DS3N-12E Cards

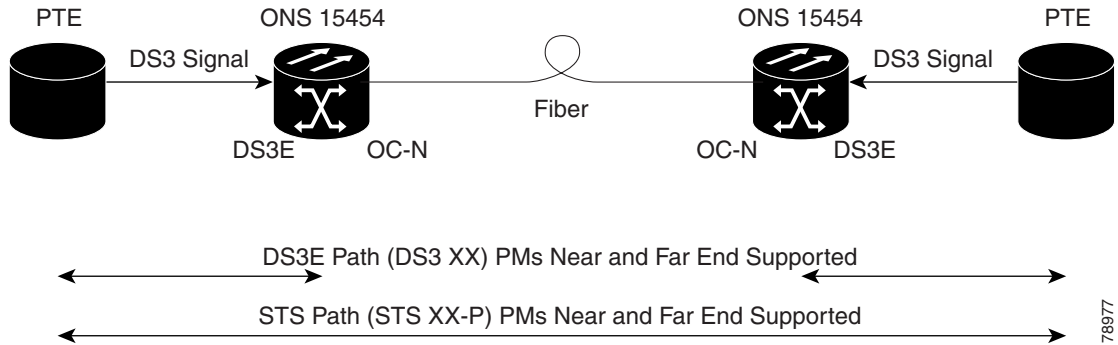

Note

The XX in Figure 15-10 represents all PMs listed in Table 15-8 with the given prefix and/or suffix.

Figure 15-11 shows where overhead bytes detected on the ASICs produce PM parameters for the DS3-12E and DS3N-12E cards.

Figure 15-11 PM Read Points on the DS3-12E and DS3N-12E Cards

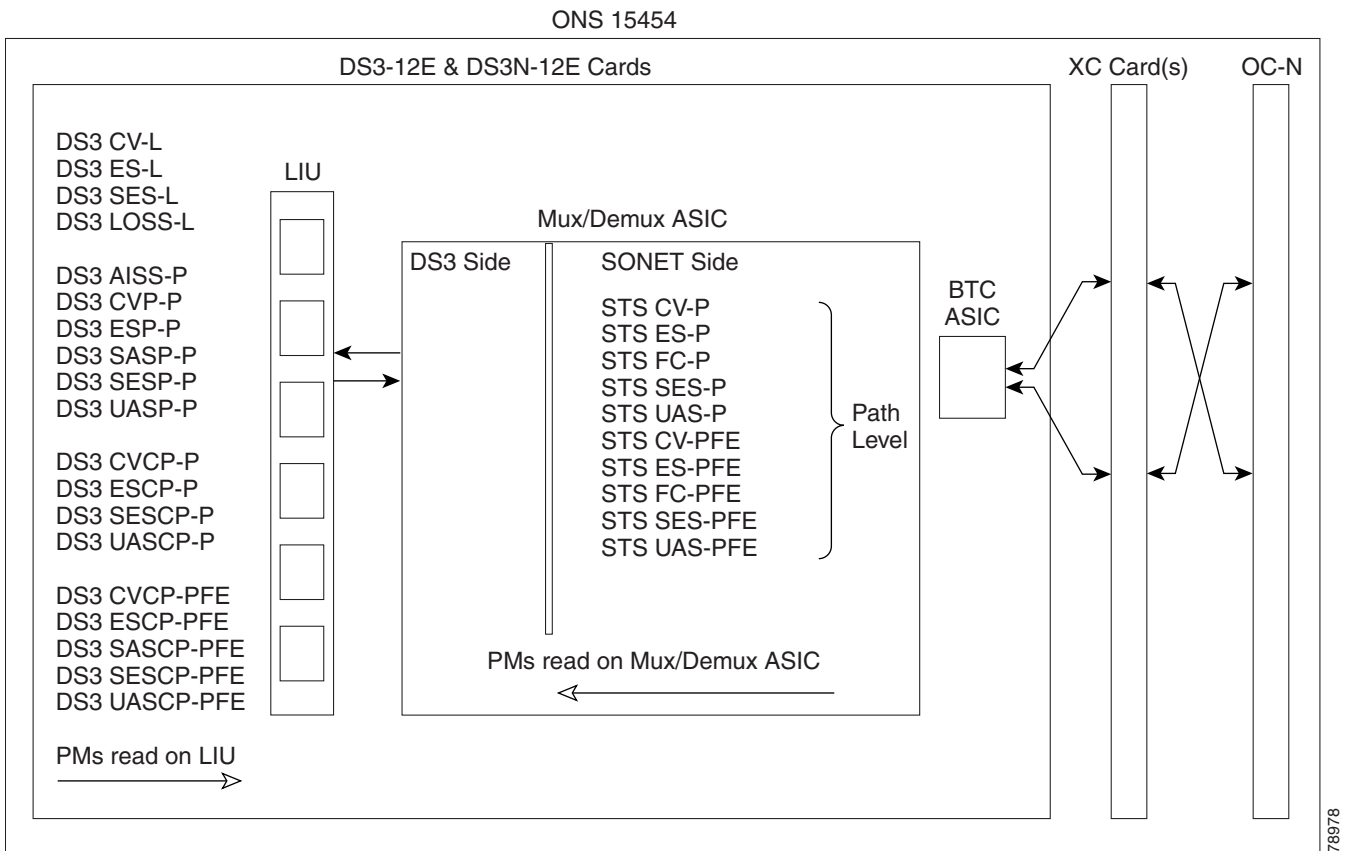

Table 15-8 describes the PM parameters for the DS3-12E and DS3N-12E cards.

Table 15-8 DS3-12E and DS3N-12E Card PMs

Line (NE)	Path (NE)	STS Path (NE)	Path (FE) ¹	STS Path (FE)
CV-L	AISS-P	CV-P	CVCP-PFE	CV-PFE
ES-L	CV-P	ES-P	ESCP-PFE	ES-PFE
SES-L	ES-P	SES-P	SASCP-P	SES-PFE
LOSS-L	SAS-P ²	UAS-P	SESCP-PFE	UAS-PFE
	SES-P	FC-P	UASCP-PFE	FC-PFE
	UAS-P			
	CVCP-P			
	ESCP-P			
	SASCP-P ³			
	SESCP-P			
	UASCP-P			

1. The C-bit PMs (PMs that contain the text "CP-P") are applicable only if the line format is C-bit.
2. DS3(N)-12E cards support SAS-P only on the receive (Rx) path.
3. The SASCP parameter is also displayed as "undefined" for near-end parameter though it is a far-end parameter.

15.5.6 DS3i-N-12 Card Performance Monitoring Parameters

Figure 15-12 shows the signal types that support near-end and far-end PMs.

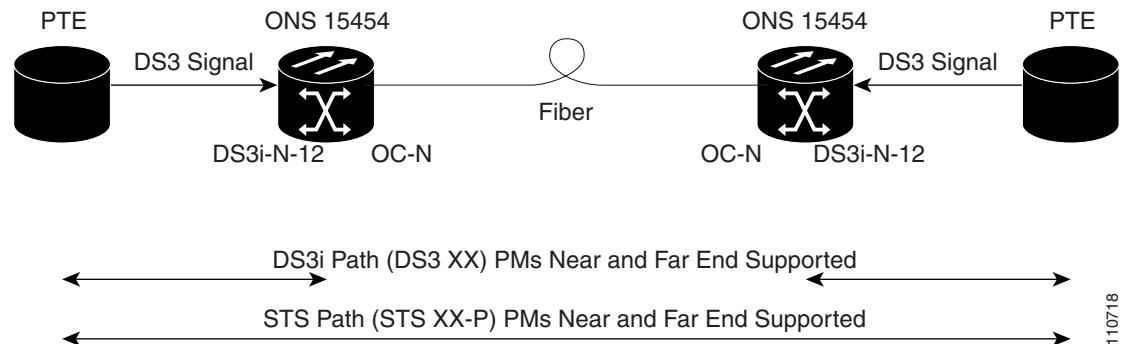
Figure 15-12 Monitored Signal Types for the DS3i-N-12 Cards**Note**

The XX in Figure 15-12 represents all PMs listed in Table 15-9 with the given prefix and/or suffix.

Figure 15-13 shows where overhead bytes detected on the ASICs produce PM parameters for the DS3i-N-12 cards.

Figure 15-13 PM Read Points on the DS3i-N-12 Cards

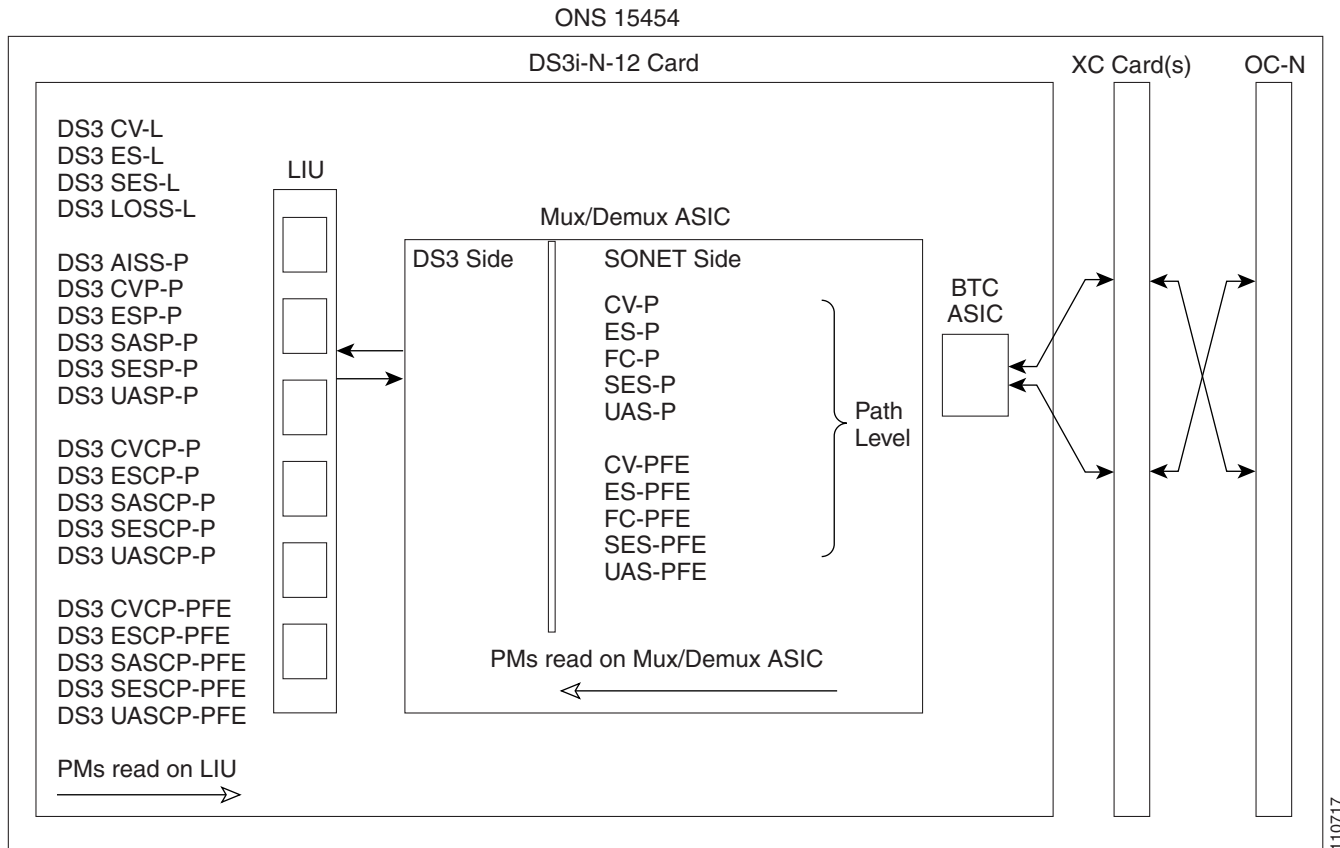

Table 15-9 describes the PM parameters for the DS3i-N-12 card.

Table 15-9 DS3i-N-12 Card PMs

Line (NE)	Path (NE)	STS Path (NE)	Path (FE) ¹	STS Path (FE)
CV-L	AISSP-P	CV-P	CVCP-PFE	CV-PFE
ES-L	CVP-P	ES-P	ESCP-PFE	ES-PFE
SES-L	ESP-P	SES-P	SASCP-PFE	SES-PFE
LOSS-L	SASP-P ²	UAS-P	SESCP-PFE	UAS-PFE
	SESP-P	FC-P	UASCP-PFE	FC-PFE
	UASP-P			
	CVCP-P			
	ESCP-P			
	SASCP-P ³			
	SESCP-P			
	UASCP-P			

1. The C-Bit PMs (PMs that contain the text "CP-P") are applicable only if the line format is C-Bit.
2. DS3i-N-12 cards support SAS-P only on the Rx path.
3. The SASCP parameter is also displayed as "undefined" for near-end parameter though it is a far-end parameter.

15.5.7 DS3XM-6 Card Performance Monitoring Parameters

Figure 15-14 shows the signal types that support near-end and far-end PMs.

Figure 15-14 Monitored Signal Types for the DS3XM-6 Card

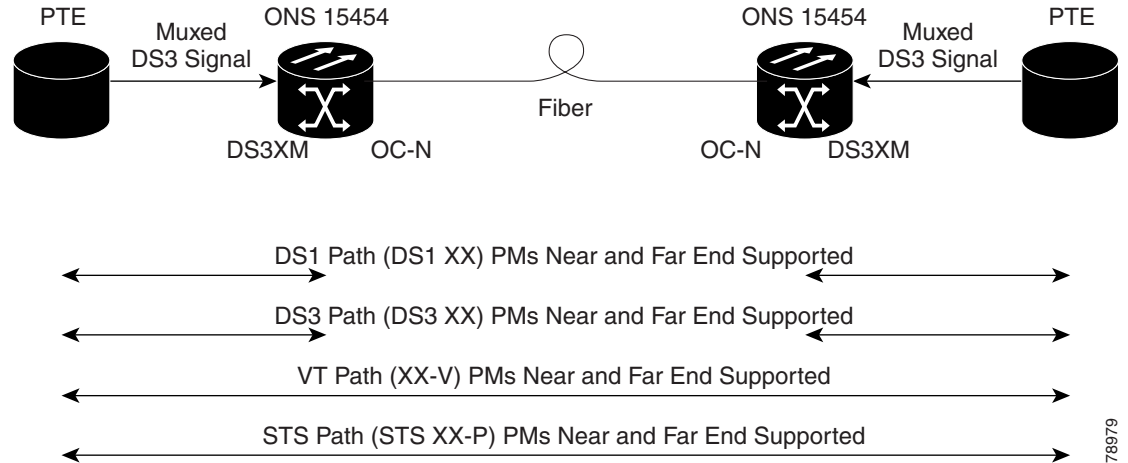

Note

The XX in Figure 15-14 represents all PMs listed in Table 15-10 with the given prefix and/or suffix.

Figure 15-15 shows where the overhead bytes detected on the ASICs produce PM parameters for the DS3XM-6 card.

78979

Figure 15-15 PM Read Points on the DS3XM-6 Card

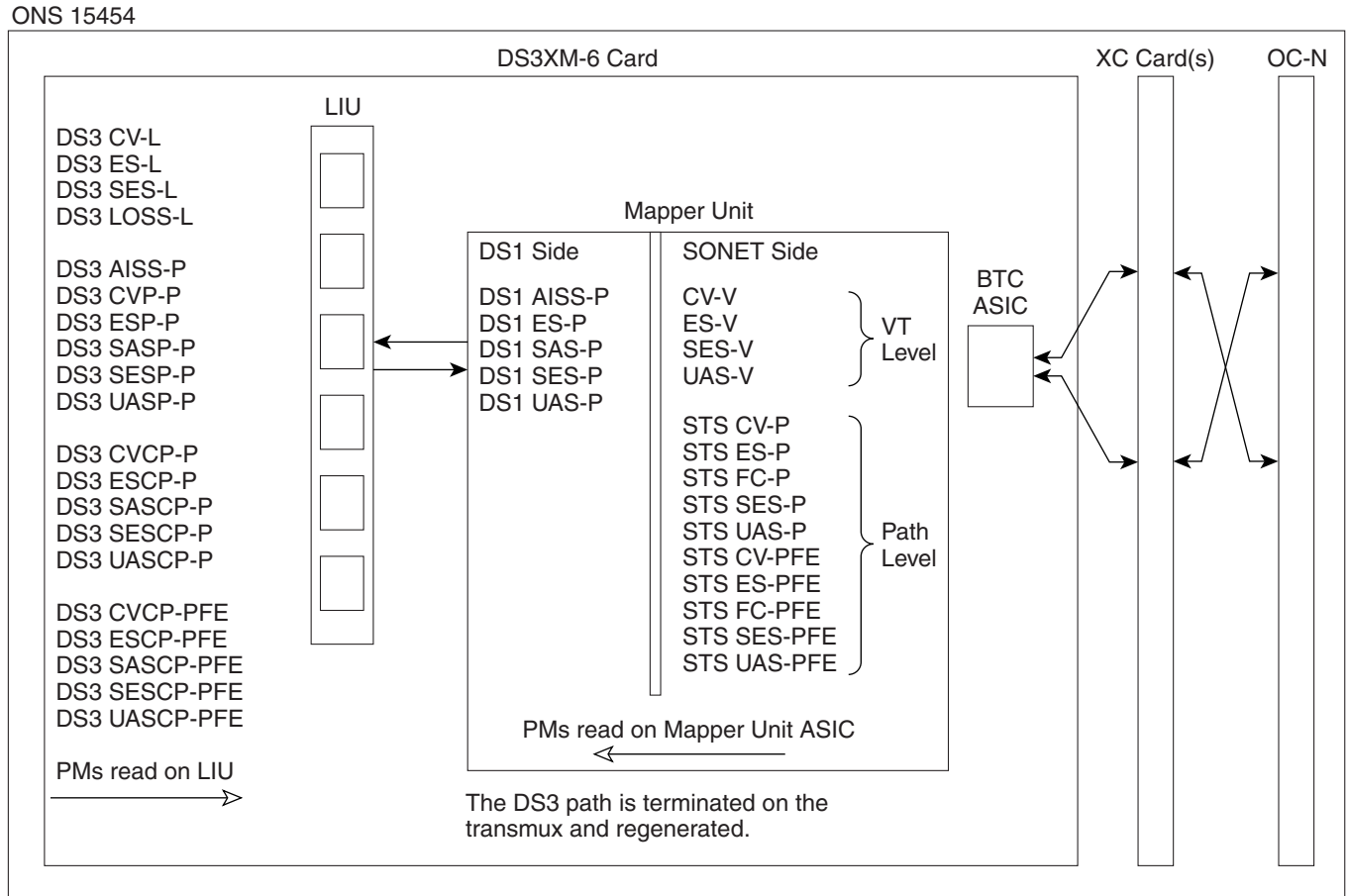

Table 15-10 lists the PM parameters for the DS3XM-6 cards.

Table 15-10 DS3XM-6 Card PMs

DS3 Line (NE)	DS3 Path (NE) ¹	DS1 Path (NE)	VT Path (NE)	STS Path (NE)	DS3 Path (FE) ¹	VT Path (FE)	STS Path (FE)	Network Path ²
CV-L	AISS-P	AISS-P	CV-V	CV-P	CVCP-PFE	CV-VFE	CV-PFE	ES-NP
ES-L	CVP-P	ES-P	ES-V	ES-P	ESCP-PFE	ES-VFE	ES-PFE	ES-NPFE
SES-L	ESP-P	SAS-P ³	SES-V	SES-P	SASCP-PFE	SES-VFE	SES-PFE	SES-NP
LOSS-L	SASP-P ³	SES-P	UAS-V	UAS-P	SESCP-PFE	UAS-VFE	UAS-PFE	SES-NPFE
	SESP-P	UAS-P		FC-P	UASCP-PFE		FC-PFE	UAS-NP
	UASP-P							UAS-NPFE
	ESCP-P							
	SASCP-P ⁴							
	SESCP-P							
	UASCP-P							
	CVCP-P							

1. The C-Bit PMs (PMs that contain the text "CP-P") are applicable only if the line format is C-Bit.
2. Parameter received from far-end direction only.
3. DS3XM-6 cards support SAS-P only on the Rx path.
4. The SASCP parameter is also displayed as "undefined" for near-end parameter though it is a far-end parameter.

15.5.8 DS3XM-12 Card Performance Monitoring Parameters

Figure 15-16 shows the signal types that support near-end and far-end PMs.

Figure 15-16 Monitored Signal Types for the DS3XM-12 Card

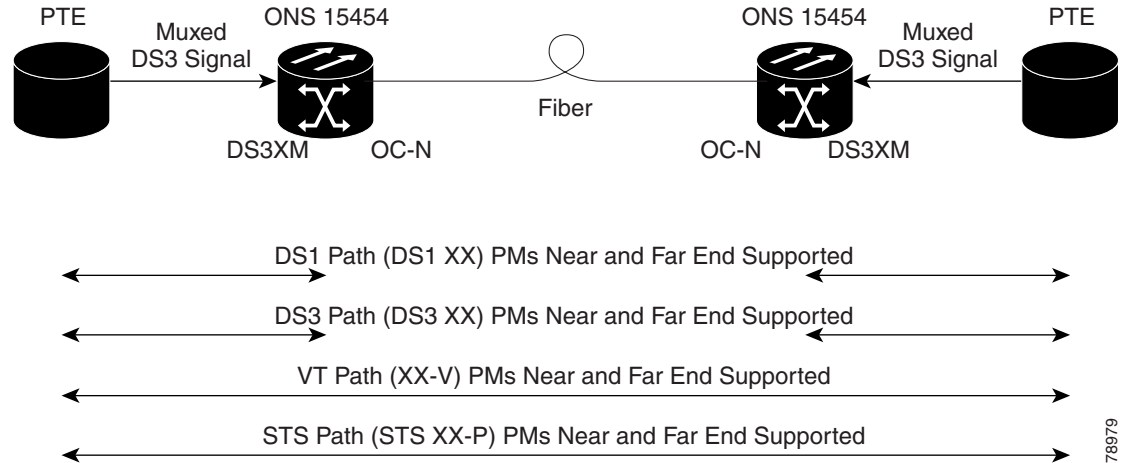

Note

The XX in Figure 15-16 represents all PMs listed in Table 15-11 with the given prefix and/or suffix.

Figure 15-17 shows where the overhead bytes detected on the ASICs produce PM parameters for the DS3XM-12 card.

Figure 15-17 PM Read Points on the DS3XM-12 Card

ONS 15454

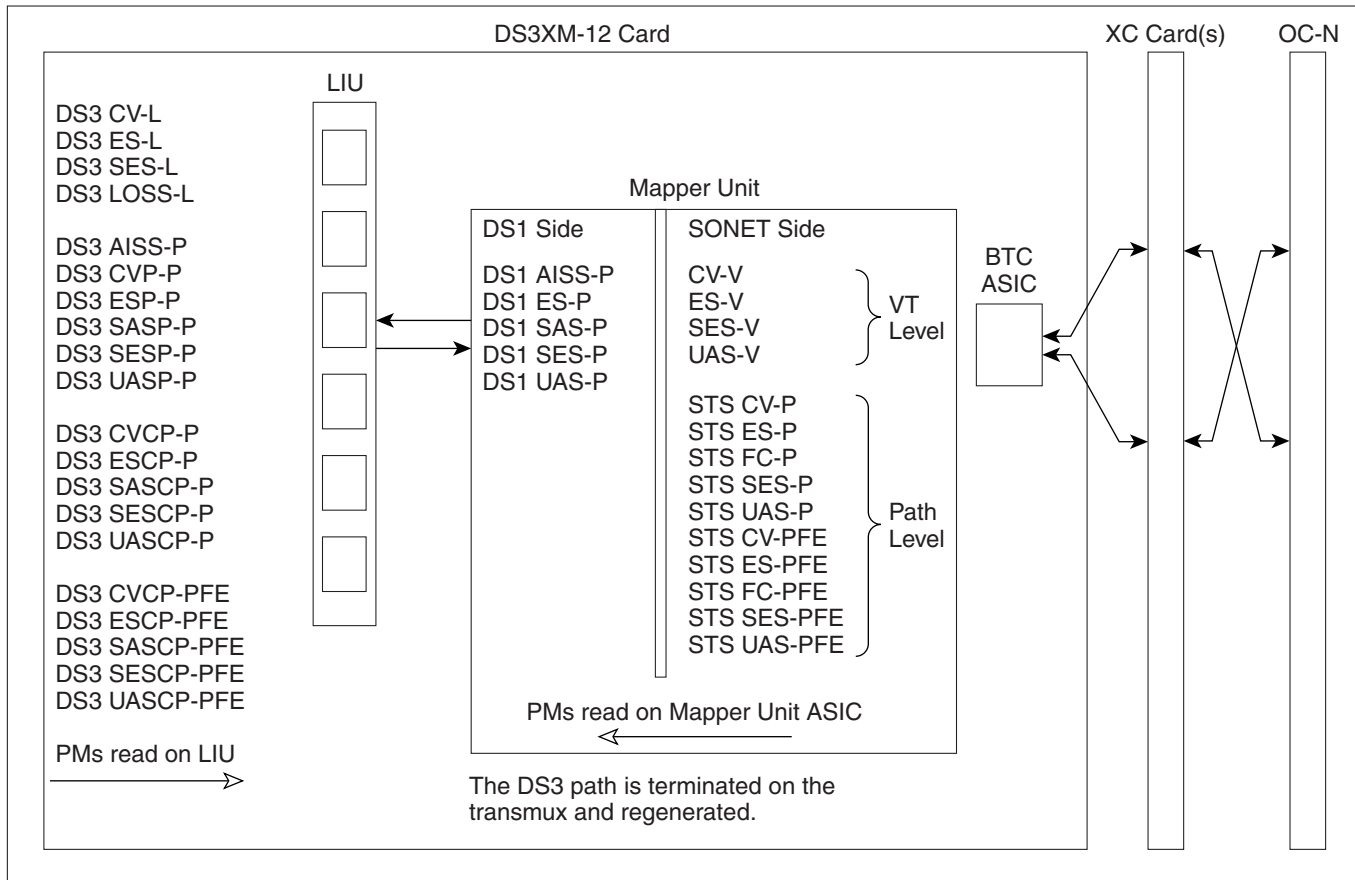

Table 15-11 lists the PM parameters for the DS3XM-12 cards.

Table 15-11 DS3XM-12 Card PMs

DS3 Line (NE)	DS3 Path (NE) ¹	DS1 Path (NE)	VT Path (NE)	STS Path (NE)	DS3 Path (FE) ¹	VT Path (FE)	STS Path (FE)	BFDL (FE)	Network Path ²
CV-L	AISS-P	AISS-P	CV-V	CV-P	CVCP-PFE	CV-VFE	CV-PFE	CSS	ES-NP
ES-L	CV-P	CV-P	ES-V	ES-P	ESCP-PFE	ES-VFE	ES-PFE	ES	ES-NPFE
SES-L	ES-P	ES-P	SES-V	SES-P	SASCP-PFE ⁴	SES-VFE	SES-PFE	SES	SES-NP
LOSS-L	SAS-P ³	FC-P	UAS-V	UAS-P	SESCP-PFE	UAS-VFE	UAS-PFE	BES	SES-NPFE
	SES-P	SAS-P ³		FC-P	UASCP-PFE		FC-PFE	UAS	SES-NPFE
	UAS-P	SES-P						LOFC	UAS-NP
	ESCP-P	UAS-P							UAS-NPFE
	SESCP-P	CSS-P							
	UASCP-P	ESA-P							
	CVCP-P	ESB-P							
		SEFS-P							

1. The C-Bit PMs (PMs that contain the text "CP-P") are applicable only if the line format is C-Bit.
2. Parameter received from far-end direction only.
3. DS3XM-12 cards support SAS-P only on the Rx path.
4. The SASCP parameter is also displayed as "undefined" for near-end parameter though it is a far-end parameter.

15.5.9 DS3/EC1-48 Card Performance Monitoring Parameters

Figure 15-18 shows the signal types that support near-end and far-end PMs.

Figure 15-18 Monitored Signal Types for the DS3/EC1-48 Card

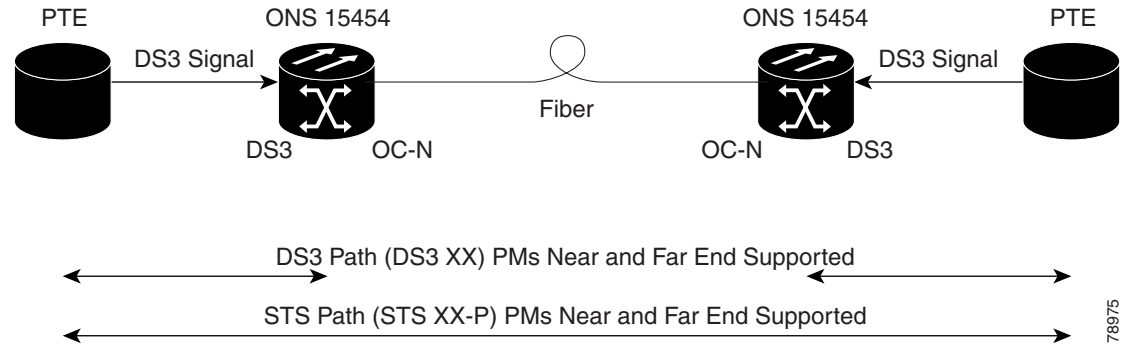

Note

The XX in Figure 15-18 represents all PMs listed in Table 15-12 with the given prefix and/or suffix.

Figure 15-19 shows where the overhead bytes detected on the ASICs produce PM parameters for the DS3-EC1-48 card.

Figure 15-19 PM Read Points on the DS3/EC1-48 Card

ONS 15454

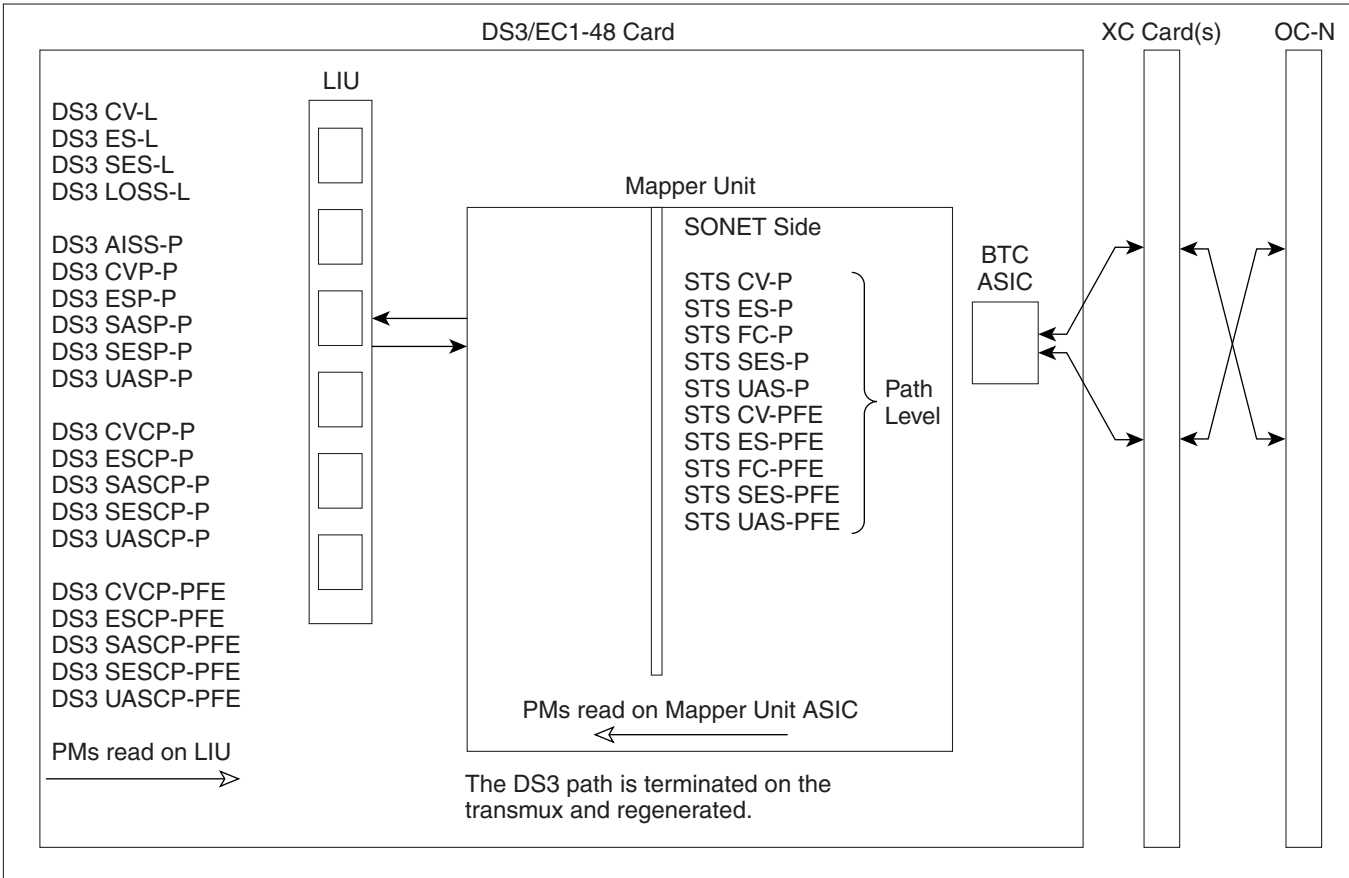

Table 15-12 lists the PM parameters for the DS3/EC1-48 cards.

Table 15-12 DS3/EC1-48 Card PMs

DS3/EC1 Line (NE)	DS3 Path (NE) ¹	STS Path (NE)	DS3 Path (FE) ¹	STS Path (FE)
CV-L	AISS-P	CV-P	CVCP-PFE	CV-PFE
ES-L	CVP-P	ES-P	ESCP-PFE	ES-PFE
SES-L	ESP-P	SES-P	SASCP-PFE	SES-PFE
LOSS-L	SASP-P ²	UAS-P	SESCP-PFE	UAS-PFE
	SESP-P	FC-P	UASCP-PFE	FC-PFE
	UASP-P			
	ESCP-P			
	SASCP-P ³			
	SESCP-P			
	UASCP-P			
	CVCP-P			

1. The C-Bit PMs (PMs that contain the text "CP-P") are applicable only if the line format is C-Bit.

2. DS3/EC1-48 cards support SAS-P only on the Rx path.

3. The SASCP parameter is also displayed as "undefined" for near-end parameter though it is a far-end parameter.

**Note**

If the CV-L(NE and FE) falls in the range 51-61 for DS3, then, the user might see discrepancy in the SES and the UAS-L values. However, ES-L will be in the nearest accuracy. For a few seconds, in a given 10 seconds interval, the number of CV-L counted may not cross the CV count criteria for SES, (due to system/application limitation for the below mentioned ranges); as a consequence of which there may not be 10 continuous SES, thus UAS will not be observed.

15.6 Performance Monitoring for Ethernet Cards

The following sections define PM parameters and definitions for the ONS 15454 E-Series, G-Series, ML-Series, and CE-Series Ethernet cards.

15.6.1 E-Series Ethernet Card Performance Monitoring Parameters

CTC provides Ethernet performance information, including line-level parameters, port bandwidth consumption, and historical Ethernet statistics. The E-Series Ethernet performance information is divided into the Statistics, Utilization, and History tabbed windows within the card view Performance tab window.

15.6.1.1 E-Series Ethernet Statistics Window

The Ethernet Statistics window lists Ethernet parameters at the line level. The Statistics window provides buttons to change the statistical values shown. The Baseline button resets the displayed statistics values to zero. The Refresh button manually refreshes statistics. Auto-Refresh sets a time interval at which automatic refresh occurs.

[Table 15-13](#) defines the E-Series Ethernet card statistics parameters.

Table 15-13 E-Series Ethernet Statistics Parameters

Parameter	Definition
Link Status	Indicates whether link integrity is present; up means present, and down means not present.
ifInOctets	Number of bytes received since the last counter reset.
ifInUcastPkts	Number of unicast packets received since the last counter reset.
ifInErrors	The number of inbound packets (or transmission units) that contained errors preventing them from being deliverable to a higher-layer protocol.
ifOutOctets	Number of bytes transmitted since the last counter reset.
ifOutUcastPkts	Number of unicast packets transmitted.
dot3StatsAlignmentErrors	A count of frames received on a particular interface that are not an integral number of octets in length and do not pass the FCS check.
dot3StatsFCSErrors	A count of frames received on a particular interface that are an integral number of octets in length but do not pass the FCS check.
dot3StatsFrameTooLong	A count of frames received on a particular interface that exceed the maximum permitted frame size.

Table 15-13 E-Series Ethernet Statistics Parameters (continued)

Parameter	Definition
etherStatsUndersizePkts	The total number of packets received that were less than 64 octets long (excluding framing bits, but including FCS octets) and were otherwise well formed.
etherStatsFragments	The total number of packets received that were less than 64 octets in length (excluding framing bits but including FCS octets) and had either a bad FCS with an integral number of octets (FCS Error) or a bad FCS with a nonintegral number of octets (Alignment Error). Note It is entirely normal for etherStatsFragments to increment. This is because it counts both runts (which are normal occurrences due to collisions) and noise hits.
etherStatsPkts64Octets	The total number of packets (including bad packets) received that were 64 octets in length (excluding framing bits but including FCS octets).
etherStatsPkts65to127 Octets	The total number of packets (including bad packets) received that were between 65 and 127 octets in length inclusive (excluding framing bits but including FCS octets).
etherStatsPkts128to255 Octets	The total number of packets (including bad packets) received that were between 128 and 255 octets in length inclusive (excluding framing bits but including FCS octets).
etherStatsPkts256to511 Octets	The total number of packets (including bad packets) received that were between 256 and 511 octets in length inclusive (excluding framing bits but including FCS octets).
etherStatsPkts512to1023 Octets	The total number of packets (including bad packets) received that were between 512 and 1023 octets in length inclusive (excluding framing bits but including FCS octets).
etherStatsPkts1024to1518 Octets	The total number of packets (including bad packets) received that were between 1024 and 1518 octets in length inclusive (excluding framing bits but including FCS octets).
etherStatsOversizePkts	The total number of packets received that were longer than 1518 octets (excluding framing bits, but including FCS octets) and were otherwise well formed. Note that for tagged interfaces, this number becomes 1522 bytes.
etherStatsJabbers	The total number of packets received that were longer than 1518 octets (excluding framing bits, but including FCS octets), and had either a bad FCS with an integral number of octets (FCS Error) or a bad FCS with a nonintegral number of octets (Alignment Error).
etherStatsOctets	The total number of octets of data (including those in bad packets) received on the network (excluding framing bits but including FCS octets)
etherStatsCRCAAlign Errors	The total number of packets received that had a length (excluding framing bits, but including FCS octets) of between 64 and 1518 octets, inclusive, but had either a bad FCS with an integral number of octets (FCS Error) or a bad FCS with a nonintegral number of octets (Alignment Error).

15.6.1.2 E-Series Ethernet Utilization Window

The Utilization window shows the percentage of transmit (Tx) and receive (Rx) line bandwidth used by the Ethernet ports during consecutive time segments. The Mode field displays the real-time mode status, such as 100 Full, which is the mode setting configured on the E-Series port. However, if the E-Series port is set to autonegotiate the mode (Auto), this field shows the result of the link negotiation between the E-Series and the peer Ethernet device attached directly to the E-Series port.

The Utilization window provides an Interval drop-down list that enables you to set time intervals of 1 minute, 15 minutes, 1 hour, and 1 day. Line utilization is calculated with the following formulas:

$$Rx = (inOctets + inPkts * 20) * 8 / 100\% \text{ interval} * \text{maxBaseRate}$$

$$Tx = (outOctets + outPkts * 20) * 8 / 100\% \text{ interval} * \text{maxBaseRate}$$

The interval is defined in seconds. The maxBaseRate is defined by raw bits per second in one direction for the Ethernet port (that is, 1 Gbps). The maxBaseRate for E-Series Ethernet cards is shown in [Table 15-14](#).

Table 15-14 maxBaseRate for STS Circuits

STS	maxBaseRate
STS-1	51840000
STS-3c	155000000
STS-6c	311000000
STS-12c	622000000



Note

Line utilization numbers express the average of ingress and egress traffic as a percentage of capacity.



Note

The E-Series Ethernet card is a Layer 2 device or switch and supports Trunk Utilization statistics. The Trunk Utilization statistics are similar to the Line Utilization statistics, but shows the percentage of circuit bandwidth used rather than the percentage of line bandwidth used. The Trunk Utilization statistics are accessed through the card view Maintenance tab.

15.6.1.3 E-Series Ethernet History Window

The Ethernet History window lists past Ethernet statistics for the previous time intervals. Depending on the selected time interval, the History window displays the statistics for each port for the number of previous time intervals as shown in [Table 15-15](#). The parameters are defined in [Table 15-13 on page 15-29](#).

Table 15-15 Ethernet History Statistics per Time Interval

Time Interval	Number of Previous Intervals Displayed
1 minute	60
15 minutes	32
1 hour	24
1 day (24 hours)	7

15.6.2 G-Series Ethernet Card Performance Monitoring Parameters

CTC provides Ethernet performance information, including line-level parameters, port bandwidth consumption, and historical Ethernet statistics. The G-Series Ethernet performance information is divided into the Statistics, Utilization, and History tabbed windows within the card view Performance tab window.

15.6.2.1 G-Series Ethernet Statistics Window

The Ethernet Statistics window lists Ethernet parameters at the line level. The Statistics window provides buttons to change the statistical values shown. The Baseline button resets the displayed statistics values to zero. The Refresh button manually refreshes statistics. Auto-Refresh sets a time interval at which automatic refresh occurs. The G-Series Statistics window also has a Clear button. The Clear button sets the values on the card to zero, but does not reset the G-Series card.

Table 15-16 defines the G-Series Ethernet card statistics parameters.

Table 15-16 G-Series Ethernet Statistics Parameters

Parameter	Definition
Time Last Cleared	A time stamp indicating the last time statistics were reset.
Link Status	Indicates whether the Ethernet link is receiving a valid Ethernet signal (carrier) from the attached Ethernet device; up means present, and down means not present.
Rx Packets	Number of packets received since the last counter reset.
Rx Bytes	Number of bytes received since the last counter reset.
Tx Packets	Number of packets transmitted since the last counter reset.
Tx Bytes	Number of bytes transmitted since the last counter reset.
Rx Total Errors	Total number of receive errors.
Rx FCS	Number of packets with a FCS error. FCS errors indicate frame corruption during transmission.
Rx Alignment	Number of packets with received incomplete frames.
Rx Runts	Measures undersized packets with bad CRC errors.
Rx Shorts	Measures undersized packets with good CRC errors.
Rx Jabbers	The total number of frames received that exceed the 1548-byte maximum and contain CRC errors.
Rx Giants	Number of packets received that are greater than 1530 bytes in length.
Rx Pause Frames	Number of received Ethernet IEEE 802.3z pause frames.
Tx Pause Frames	Number of transmitted IEEE 802.3z pause frames.
Rx Pkts Dropped Internal Congestion	Number of received packets dropped due to overflow in G-Series frame buffer.
Tx Pkts Dropped Internal Congestion	Number of transmit queue drops due to drops in the G-Series frame buffer.
HDLC Errors	High-level data link control (HDLC) errors received from SONET/SDH (see Note).

Table 15-16 G-Series Ethernet Statistics Parameters (continued)

Parameter	Definition
Rx Unicast Packets	Number of unicast packets received since the last counter reset.
Tx Unicast Packets	Number of unicast packets transmitted.
Rx Multicast Packets	Number of multicast packets received since the last counter reset.
Tx Multicast Packets	Number of multicast packets transmitted.
Rx Broadcast Packets	Number of broadcast packets received since the last counter reset.
Tx Broadcast Packets	Number or broadcast packets transmitted.

**Note**

Do not use the HDLC errors counter to count the number of frames dropped because of HDLC errors, because each frame can fragment into several smaller frames during HDLC error conditions and spurious HDLC frames can be generated. If HDLC error counters are incrementing when no SONET path problems should be present, it might indicate a problem with the quality of the SONET path. For example, a SONET protection switch generates a set of HDLC errors. However, the actual values of these counters are less significant than the fact that they are changing.

15.6.2.2 G-Series Ethernet Utilization Window

The Utilization window shows the percentage of Tx and Rx line bandwidth used by the Ethernet ports during consecutive time segments. The Mode field displays the real-time mode status, such as 100 Full, which is the mode setting configured on the G-Series port. However, if the G-Series port is set to autonegotiate the mode (Auto), this field shows the result of the link negotiation between the G-Series and the peer Ethernet device attached directly to the G-Series port.

The Utilization window provides an Interval drop-down list that enables you to set time intervals of 1 minute, 15 minutes, 1 hour, and 1 day. Line utilization is calculated with the following formulas:

$$\text{Rx} = (\text{inOctets} + \text{inPkts} * 20) * 8 / 100\% \text{ interval} * \text{maxBaseRate}$$

$$\text{Tx} = (\text{outOctets} + \text{outPkts} * 20) * 8 / 100\% \text{ interval} * \text{maxBaseRate}$$

The interval is defined in seconds. The maxBaseRate is defined by raw bits per second in one direction for the Ethernet port (that is, 1 Gbps). The maxBaseRate for G-Series Ethernet cards is shown in [Table 15-14](#).

**Note**

Line utilization numbers express the average of ingress and egress traffic as a percentage of capacity.

**Note**

Unlike the E-Series, the G-Series card does not have a display of Trunk Utilization statistics, because the G-Series card is not a Layer 2 device or switch.

15.6.2.3 G-Series Ethernet History Window

The Ethernet History window lists past Ethernet statistics for the previous time intervals. Depending on the selected time interval, the History window displays the statistics for each port for the number of previous time intervals as shown in [Table 15-15 on page 15-31](#). The listed parameters are defined in [Table 15-16 on page 15-32](#).

15.6.3 ML-Series Ethernet Card Performance Monitoring Parameters

CTC provides Ethernet performance information for line-level parameters and historical Ethernet statistics. The ML-Series Ethernet performance information is divided into the Ether Ports, Packet-over-SONET (POS) Ports, and RPR Span tabbed windows within the card view Performance tab window. These tabs may vary depending on the card selected.

15.6.3.1 ML-Series Ether Ports Statistics Window

The Ethernet Ether Ports Statistics window lists Ethernet parameters at the line level. The Statistics window provides buttons to change the statistical values shown. The Baseline button resets the displayed statistics values to zero. The Refresh button manually refreshes statistics. Auto-Refresh sets a time interval at which automatic refresh occurs. The ML-Series Statistics window also has a Clear button. The Clear button sets the values on the card to zero, but does not reset the ML-Series card.

During each automatic cycle, whether auto-refreshed or manually refreshed (using the Refresh button), statistics are added cumulatively and are not immediately adjusted to equal total received packets until testing ends. To see the final PM count totals, allow a few moments for the PM window statistics to finish testing and update fully. PM counts are also listed in the ML-Series card Performance > History window. [Table 15-17](#) defines the ML-Series Ethernet card Ether Ports PM parameters.

Table 15-17 ML-Series Ether Ports PM Parameters

Parameter	Definition
ifInOctets	Number of bytes received since the last counter reset.
rxTotalPackets	Number of packets received.
ifInUcastPkts	Number of unicast packets received since the last counter reset.
ifInMulticast Pkts	Number of multicast packets received since the last counter reset.
ifInBroadcast Pkts	Number of broadcast packets received since the last counter reset.
ifInDiscards	The number of inbound packets that were chosen to be discarded even though no errors had been detected to prevent their being deliverable to a higher-layer protocol. One possible reason for discarding such a packet could be to free up buffer space.
ifInErrors	The number of inbound packets (or transmission units) that contained errors preventing them from being deliverable to a higher-layer protocol.
ifOutOctets	Number of bytes transmitted since the last counter reset.
txTotalPkts	Number of transmitted packets.
ifOutUcast Pkts	Number of unicast packets transmitted.
ifOutMulticast Pkts	Number of multicast packets transmitted.
ifOutBroadcast Pkts	Number or broadcast packets transmitted.

Table 15-17 ML-Series Ether Ports PM Parameters (continued)

Parameter	Definition
dot3StatsAlignmentErrors	A count of frames received on a particular interface that are not an integral number of octets in length and do not pass the FCS check.
dot3StatsFCSErrors	A count of frames received on a particular interface that are an integral number of octets in length but do not pass the FCS check.
dot3StatsSingleCollisionFrames	A count of successfully transmitted frames on a particular interface for which transmission is inhibited by exactly one collision.
dot3StatsFrameTooLong	A count of frames received on a particular interface that exceed the maximum permitted frame size.
etherStatsUndersizePkts	The total number of packets received that were less than 64 octets long (excluding framing bits, but including FCS octets) and were otherwise well formed.
etherStatsOversizePkts	The total number of packets received that were longer than 1518 octets (excluding framing bits, but including FCS octets) and were otherwise well formed. Note that for tagged interfaces, this number becomes 1522 bytes.
etherStatsFragments	The total number of packets received that were less than 64 octets in length (excluding framing bits but including FCS octets) and had either a bad FCS with an integral number of octets (FCS Error) or a bad FCS with a nonintegral number of octets (Alignment Error).  Note Note: It is entirely normal for etherStatsFragments to increment. This is because it counts both runts (which are normal occurrences due to collisions) and noise hits.
etherStatsPkts64Octets	The total number of packets (including bad packets) received that were 64 octets in length (excluding framing bits but including FCS octets).
etherStatsPkts65to127Octets	The total number of packets (including bad packets) received that were between 65 and 127 octets in length inclusive (excluding framing bits but including FCS octets).
etherStatsPkts128to255Octets	The total number of packets (including bad packets) received that were between 128 and 255 octets in length inclusive (excluding framing bits but including FCS octets).
etherStatsPkts256to511Octets	The total number of packets (including bad packets) received that were between 256 and 511 octets in length inclusive (excluding framing bits but including FCS octets).
etherStatsPkts512to1023Octets	The total number of packets (including bad packets) received that were between 512 and 1023 octets in length inclusive (excluding framing bits but including FCS octets).
etherStatsPkts1024to1518Octets	The total number of packets (including bad packets) received that were between 1024 and 1518 octets in length inclusive (excluding framing bits but including FCS octets).
etherStatsBroadcastPkts	The total number of good packets received that were directed to the broadcast address. Note that this does not include multicast packets.

Table 15-17 ML-Series Ether Ports PM Parameters (continued)

Parameter	Definition
etherStatsMulticastPkts	The total number of good packets received that were directed to a multicast address. Note that this number does not include packets directed to the broadcast address.
etherStatsJabbers	The total number of packets received that were longer than 1518 octets (excluding framing bits, but including FCS octets), and had either a bad FCS with an integral number of octets (FCS Error) or a bad FCS with a nonintegral number of octets (Alignment Error).
etherStatsOctets	The total number of octets of data (including those in bad packets) received on the network (excluding framing bits but including FCS octets).
etherStatsCollissions	Number of transmit packets that are collisions; the port and the attached device transmitting at the same time caused collisions.
etherStatsCRCAlignErrors	The total number of packets received that had a length (excluding framing bits, but including FCS octets) of between 64 and 1518 octets, inclusive, but had either a bad FCS with an integral number of octets (FCS Error) or a bad FCS with a nonintegral number of octets (Alignment Error).
etherStatsDropEvents	Number of received frames dropped at the port level.
rx PauseFrames ¹	Number of received Ethernet 802.3z pause frames.
mediaIndStatsOversizeDropped ¹	Number of received oversized packages that are dropped.
mediaIndStatsTxFramesTooLong ¹	Number of received frames that are too long. The maximum is the programmed max frame size (for virtual SAN [VSAN] support); if the maximum frame size is set to default, then the maximum is a 2112 byte payload plus the 36 byte header, which is a total of 2148 bytes.

1. ML100T-12, ML1000-2 only

15.6.3.2 ML-Series Card Ether Ports Utilization Window

The Ether Ports Utilization window shows the percentage of Tx and Rx line bandwidth used by the Ethernet ports during consecutive time segments. The Utilization window provides an Interval drop-down list that enables you to set time intervals of 1 minute, 15 minutes, 1 hour, and 1 day. Line utilization is calculated with the following formulas:

$$\text{Rx} = (\text{inOctets} + \text{inPkts} * 20) * 8 / 100\% \text{ interval} * \text{maxBaseRate}$$

$$\text{Tx} = (\text{outOctets} + \text{outPkts} * 20) * 8 / 100\% \text{ interval} * \text{maxBaseRate}$$

The interval is defined in seconds. The maxBaseRate is defined by raw bits per second in one direction for the Ethernet port (that is, 1 Gbps). The maxBaseRate for ML-Series Ethernet cards is shown in [Table 15-14](#).



Note

Line utilization numbers express the average of ingress and egress traffic as a percentage of capacity.

15.6.3.3 ML-Series Card Ether Ports History Window

The Ethernet Ether Ports History window lists past Ethernet statistics for the previous time intervals. Depending on the selected time interval, the History window displays the statistics for each port for the number of previous time intervals as shown in [Table 15-15 on page 15-31](#). The listed parameters are defined in [Table 15-17 on page 15-34](#).

15.6.3.4 ML-Series POS Ports Window

In the ML-Series POS Ports window, the parameters displayed depend on the framing mode employed by the ML-Series card. The two framing modes for the POS port on the ML-Series card are HDLC and frame-mapped generic framing procedure (GFP-F). For more information on provisioning a framing mode, refer to *Cisco ONS 15454 Procedure Guide*.

[Table 15-18](#) defines the ML-Series Ethernet card POS Ports HDLC parameters. [Table 15-19](#) defines the ML-Series Ethernet card POS Ports GFP-F parameters.

Table 15-18 ML-Series POS Ports Parameters for HDLC Mode

Parameter	Definition
ifInOctets	Number of bytes received since the last counter reset.
rxTotalPkts	Number of packets received.
ifOutOctets	Number of bytes transmitted since the last counter reset.
tx TotalPkts	Number of transmitted packets.
etherStatsDropEvents	Number of received frames dropped at the port level.
rxPktsDropped Internal Congestion	Number of received packets dropped due to overflow in frame buffer.
mediaIndStatsRxFrames Truncated	Number of received frames with a length of 36 bytes or less.
mediaIndStatsRxFrames TooLong	Number of received frames that are too long. The maximum is the programmed maximum frame size (for VSAN support); if the maximum frame size is set to default, then the maximum is the 2112 byte payload plus the 36 byte header, which is a total of 2148 bytes.
mediaIndStatsRxFrames BadCRC	Number of received frames with CRC errors.
mediaIndStatsRxShort Pkts	Number of received packets that are too small.
hdlcInOctets	Number of bytes received (from the SONET/SDH path) prior to the bytes undergoing HLDC decapsulation by the policy engine.
hdlcRxAborts	Number of received packets aborted on input.
hdlcOutOctets	Number of bytes transmitted (to the SONET/SDH path) after the bytes undergoing HLDC encapsulation by the policy engine.

Table 15-19 ML-Series POS Ports Parameters for GFP-F Mode

Parameter	Meaning
etherStatsDropEvents	Number of received frames dropped at the port level.
rx PktsDroppedInternal Congestion	Number of received packets dropped due to overflow in the frame buffer.
gfpStatsRxFrame	Number of received GFP frames.
gfpStatsTxFrame	Number of transmitted GFP frames.
gfpStatsRxOctets	Number of GFP bytes received.
gfpStatsTxOctets	Number of GFP bytes transmitted.
gfpStatsRxSBitErrors	Sum of all the single bit errors. In the GFP CORE HDR at the GFP-T receiver, these are correctable.
gfpStatsRxMBitErrors	Sum of all the multiple bit errors. In the GFP CORE HDR at the GFP-T receiver, these are uncorrectable.
gfpStatsRxTypeInvalid	Number of receive packets dropped due to Client Data Frame UPI errors.
gfpStatsRxCRCErrors	Number of packets received with a payload FCS error.
gfpStatsLFDRaised	Count of core HEC CRC multiple bit errors. Note This count is only of eHec multiple bit errors when in frame. This can be looked at as a count of when the state machine goes out of frame.
gfpStatsCSFRaised	Number of GFP Client signal fail frames detected at the GFP-T receiver.
mediaIndStatsRxFrames Truncated	Number of received frames that are too long. The maximum is the programmed maximum frame size (for VSAN support); if the maximum frame size is set to default, then the maximum is the 2112 byte payload plus the 36 byte header, which is a total of 2148 bytes.
mediaIndStatsRxFramesTooLong	Number of received frames with CRC error.s
mediaIndStatsRxShortPkts	Number of received packets that are too small.

15.6.3.5 ML-Series RPR Span Window

The parameters that appear in the ML-Series RPR Span window are the mandatory attributes of the 802.17 MIB. For more information on provisioning a framing mode, refer to *Cisco ONS 15454 Procedure Guide*.

Table 15-20 defines the ML-Series Ethernet card RPR Span parameters.

Table 15-20 ML-Series RPR Span Parameters for 802.17 MIB

Parameter	Meaning
gfpStatsRxSBitErrors	Sum of all the single bit errors. In the GFP CORE HDR at the GFP-T receiver, these are correctable.
gfpStatsRxMBitErrors	Sum of all the multiple bit errors. In the GFP CORE HDR at the GFP-T receiver, these are uncorrectable.

Table 15-20 ML-Series RPR Span Parameters for 802.17 MIB (continued)

Parameter	Meaning
gfpStatsRxTypeInvalid	Number of receive packets dropped due to Client Data Frame UPI errors.
rprSpanStatsInUcastClassC Frames	Number of received (PHY to MAC) classC unicast frames.
rprSpanStatsInUcastClassC Octets	Number of received (PHY to MAC) classC unicast octets.
rprSpanStatsInMcastClassC Frames	Number of received (PHY to MAC) classC multicast and broadcast frames.
rprSpanStatsInMcastClassC Octets	Number of received (PHY to MAC) classC multicast and broadcast octets.
rprSpanStatsInUcastClassB EirFrames	Number of received (PHY to MAC) classB EIR unicast frames.
rprSpanStatsInUcastClassB EirOctets	Number of received (PHY to MAC) classB EIR unicast octets.
rprSpanStatsInMcastClassB EirFrames	Number of received (PHY to MAC) classB EIR multicast and broadcast frames.
rprSpanStatsInMcastClassB EirOctets	Number of received (PHY to MAC) classB EIR multicast and broadcast octets.
rprSpanStatsInUcastClassB CirFrames	Number of received (PHY to MAC) classB CIR unicast frames.
rprSpanStatsInUcastClassB CirOctets	Number of received (PHY to MAC) classB CIR unicast octets.
rprSpanStatsInMcastClassB CirFrames	Number of received (PHY to MAC) classB CIR multicast and broadcast frames.
rprSpanStatsInMcastClassB CirOctets	Number of received (PHY to MAC) classB CIR multicast and broadcast octets.
rprSpanStatsInUcastClassA Frames	Number of received (PHY to MAC) classA unicast frames.
rprSpanStatsInUcastClassA Octets	Number of received (PHY to MAC) classA unicast octets.
rprSpanStatsInMcastClassA Frames	Number of received (PHY to MAC) classA multicast and broadcast frames.
rprSpanStatsInMcastClassA Octets	Number of received (PHY to MAC) classA multicast and broadcast octets.
rprSpanStatsInCtrlFrames	Number of received (PHY to MAC) control frames processed by this MAC. This does not include control frames in transit, i.e. a multicast control frame received from a ringlet will be counted as In but not Out. This does not include Fairness or idle frames.
rprSpanStatsInOamEcho Frames	Number of received (PHY to MAC) OAM echo frames processed by this MAC.
rprSpanStatsInOamFlush Frames	Number of received (PHY to MAC) OAM flush frames processed by this MAC.

Table 15-20 ML-Series RPR Span Parameters for 802.17 MIB (continued)

Parameter	Meaning
rprSpanStatsInOamOrgFrames	Number of received (PHY to MAC) OAM Org frames processed by this MAC.
rprSpanStatsInTopoAtdFrames	Number of received (PHY to MAC) Topology ATD frames processed by this MAC.
rprSpanStatsInTopoChkSum Frames	Number of received (PHY to MAC) topology checksum frames processed by this MAC.
rprSpanStatsInTopoTpFrames	Number of received (PHY to MAC) topology TP frames processed by this MAC.
rprSpanStatsOutUcastClassC Frames	Number of transmitted (MAC to PHY) classC unicast frames.
rprSpanStatsOutUcastClassC Octets	Number of transmitted (MAC to PHY) classC unicast octets.
rprSpanStatsOutMcastClassC Frames	Number of transmitted (MAC to PHY) classC multicast and broadcast frames.
rprSpanStatsOutMcastClassC Octets	Number of transmitted (MAC to PHY) classC multicast and broadcast octets.
rprSpanStatsOutUcastClassB EirFrames	Number of transmitted (MAC to PHY) classB EIR unicast frames
rprSpanStatsOutUcastClassB EirOctets	The number of transmitted (MAC to PHY) classB EIR unicast octets.
rprSpanStatsOutMcastClassB EirFrames	The number of transmitted (MAC to PHY) classB EIR multicast and broadcast frames.
rprSpanStatsOutMcastClassB EirOctets	The number of transmitted (MAC to PHY) classB EIR multicast and broadcast octets.
rprSpanStatsOutUcastClassB CirFrames	The number of transmitted (MAC to PHY) classB CIR unicast frames.
rprSpanStatsOutUcastClassB CirOctets	The number of transmitted (MAC to PHY) classB CIR unicast octets.
rprSpanStatsOutMcastClassB CirFrames	The number of transmitted (MAC to PHY) classB CIR multicast and broadcast frames.
rprSpanStatsOutMcastClassB CirOctets	The number of transmitted (MAC to PHY) classB CIR multicast and broadcast octets.
rprSpanStatsOutUcastClassA Frames	The number of transmitted (MAC to PHY) classA unicast frames.
rprSpanStatsOutUcastClassA Octets	The number of transmitted (MAC to PHY) classA unicast octets.
rprSpanStatsOutMcastClassA Frames	The number of transmitted (MAC to PHY) classA multicast and broadcast frames.
rprSpanStatsOutMcastClassA Octets	The number of transmitted (MAC to PHY) classA multicast and broadcast octets.

Table 15-20 ML-Series RPR Span Parameters for 802.17 MIB (continued)

Parameter	Meaning
rprSpanStatsOutCtrlFrames	The number of transmitted (MAC to PHY) control frames generated by this MAC. This does not include control frames in transit, i.e. a multicast control frame received from a ringlet will be counted as In but not Out. This does not include Fairness or idle frames.
rprSpanStatsOutOamEcho Frames	The number of transmitted (MAC to PHY) OAM echo frames generated by this MAC.
rprSpanStatsOutOamFlush Frames	The number of transmitted (MAC to PHY) OAM flush frames generated by this MAC.
rprSpanStatsOutOamOrg Frames	The number of transmitted (MAC to PHY) OAM Org frames generated by this MAC.
rprSpanStatsOutTopoAtd Frames	The number of transmitted (MAC to PHY) topology ATD frames generated by this MAC.
rprSpanStatsOutTopoChkSum Frames	The number of transmitted (MAC to PHY) topology checksum frames generated by this MAC.
rprSpanStatsOutTopoTp Frames	The number of transmitted (MAC to PHY) topology TP frames generated by this MAC.
rprClientStatsInUcastClassC Frames	The number of MAC to client classC unicast frames.
rprClientStatsInUcastClassC Octets	The number of MAC to client classC unicast octets.
rprClientStatsInMcastClassC Frames	The number of MAC to client classC multicast and broadcast frames.
rprClientStatsInMcastClassC Octets	The number of MAC to client classC multicast and broadcast octets.
rprClientStatsInUcastClassB EirFrames	The number of MAC to client classB EIR unicast frames.
rprClientStatsInUcastClassB EirOctets	Number of packets received with a payload FCS error.
rprClientStatsInMcastClassB EirFrames	Number of MAC to client classB EIR multicast and broadcast frames
rprClientStatsInMcastClassB EirOctets	Number of MAC to client classB EIR multicast and broadcast octets.
rprClientStatsInUcastClassB CirFrames	Number of MAC to client classB CIR unicast frames.
rprClientStatsInUcastClassB CirOctets	Number of MAC to client classB CIR unicast octets.
rprClientStatsInMcastClassB CirFrames	Number of MAC to client classB CIR multicast and broadcast frames.
rprClientStatsInMcastClassB CirOctets	Number of MAC to client classB CIR multicast and broadcast octets
rprClientStatsInUcastClassA Frames	Number of MAC to client classA unicast frames.

Table 15-20 ML-Series RPR Span Parameters for 802.17 MIB (continued)

Parameter	Meaning
rprClientStatsInUcastClassA Octets	Number of MAC to client classA unicast octets.
rprClientStatsInMcastClassA Frames	Number of MAC to client classA multicast and broadcast frames.
rprClientStatsInMcastClassA Octets	Number of MAC to client classA multicast and broadcast octets.
rprClientStatsInBcastFrames	Number of MAC to client broadcast frames. This is used only when deriving the multicast and broadcast packet counters for the interface MIB.
rprClientStatsOutUcastClassC Frames	Number of client to MAC classC unicast frames.
rprClientStatsOutUcastClassC Octets	Number of client to MAC classC unicast octets.
rprClientStatsOutMcastClassC Frames	Number of client to MAC classC multicast and broadcast frames.
rprClientStatsOutMcastClassC Octets	Number of client to MAC classC multicast and broadcast octets.
rprClientStatsOutUcastClassB EirFrames	Number of client to MAC classB EIR unicast frames.
rprClientStatsOutUcastClassB EirOctets	Number of client to MAC classB EIR unicast octets.
rprClientStatsOutMcastClassB EirFrames	Number of client to MAC classB EIR multicast and broadcast frames.
rprClientStatsOutMcastClassB EirOctets	Number of client to MAC classB EIR multicast and broadcast octets.
rprClientStatsOutUcastClassB CirFrames	Number of client to MAC classB CIR unicast frames.
rprClientStatsOutUcastClassB CirOctets	Number of client to MAC classB CIR unicast octets.
rprClientStatsOutMcastClassB CirFrames	Number of client to MAC classB CIR multicast and broadcast frames.
rprClientStatsOutMcastClassB CirOctets	Number of client to MAC classB CIR multicast and broadcast octets.
rprClientStatsOutUcastClassA Frames	Number of client to MAC classA unicast frames.
rprClientStatsOutUcastClassA Octets	Number of client to MAC classA unicast octets.
rprClientStatsOutMcastClassA Frames	Number of client to MAC classA multicast and broadcast frames.
rprClientStatsOutMcastClassA Octets	Number of client to MAC classA multicast and broadcast octets.

Table 15-20 ML-Series RPR Span Parameters for 802.17 MIB (continued)

Parameter	Meaning
rprClientStatsOutBcastFrames	Number of client to MAC broadcast frames. This is used only when deriving the multicast and broadcast packet counters for the interface MIB.
rprErrorStatsBadParityFrames	Number of received (PHY to MAC) frames parity value not matching the expected parity value
rprErrorStatsBadHecFrames	The number of received (PHY to MAC) frames with HEC error
rprErrorStatsTtlExpFrames	The number of received (PHY to MAC) frames that were dropped due to zero Time To Live (TTL).
rprErrorStatsTooLongFrames	The number of received (PHY to MAC) frames that exceed the maximum permitted frame size.
rprErrorStatsTooShortFrames	The number of received (PHY to MAC) frames shortest than the minimum permitted frame size.
rprErrorStatsBadFcsFrames	The number of received (PHY to MAC) data and control frames where the fcs value did not match the expected fcs value.
rprErrorStatsSelfSrcUcastFrames	The number of received (PHY to MAC) unicast frames that were transmitted by the station itself. That is, the source MAC is equal to the interface MAC.
rprErrorStatsPmdAbortFrames	The number of received (PHY to MAC) frames that were aborted by the PMD.
rprErrorStatsBadAddrFrames	The number of received (PHY to MAC) frames with invalid SA value.
rprErrorStatsContainedFrames	The number of received (PHY to MAC) frames that were removed due to context containment.
rprErrorStatsScffErrors	The number of received (PHY to MAC) errored SCFF, with bad parity, bad FCS, or both.
gpfStatsCSFRaised	The number of total received client management frames.
gfpStatsLFDRaised	The number of Core HEC CRC Multiple Bit Errors.
	 <p>Note This count is only for cHEC multiple bit error when in frame. It is a count of when the state machine goes out of frame.</p>
rprPortCounterError	Packets dropped internally by the network processor.

15.6.4 CE-Series Ethernet Card Performance Monitoring Parameters

CTC provides Ethernet performance information, including line-level parameters, port bandwidth consumption, and historical Ethernet statistics. The CE-Series card Ethernet performance information is divided into Ether Ports and POS Ports tabbed windows within the card view Performance tab window.

15.6.4.1 CE-Series Card Ether Port Statistics Window

The Ethernet Ether Ports Statistics window lists Ethernet parameters at the line level. The Statistics window provides buttons to change the statistical values shown. The Baseline button resets the displayed statistics values to zero. The Refresh button manually refreshes statistics. Auto-Refresh sets a time interval at which automatic refresh occurs. The CE-Series Statistics window also has a Clear button. The Clear button sets the values on the card to zero, but does not reset the CE-Series card.

During each automatic cycle, whether auto-refreshed or manually refreshed (using the Refresh button), statistics are added cumulatively and are not immediately adjusted to equal total received packets until testing ends. To see the final PM count totals, allow a few moments for the PM window statistics to finish testing and update fully. PM counts are also listed in the CE-Series card Performance > History window.

Table 15-21 defines the CE-Series card Ethernet port parameters.

Table 15-21 CE-Series Ether Port PM Parameters

Parameter	Definition
Time Last Cleared	A time stamp indicating the last time statistics were reset.
Link Status	Indicates whether the Ethernet link is receiving a valid Ethernet signal (carrier) from the attached Ethernet device; up means present, and down means not present.
ifInOctets	Number of bytes received since the last counter reset.
rxTotalPkts	Number of received packets.
ifInUcastPkts	Number of unicast packets received since the last counter reset.
ifInMulticastPkts	Number of multicast packets received since the last counter reset.
ifInBroadcastPkts	Number of broadcast packets received since the last counter reset.
ifInDiscards	The number of inbound packets that were chosen to be discarded even though no errors had been detected to prevent their being deliverable to a higher-layer protocol. One possible reason for discarding such a packet could be to free buffer space.
ifInErrors	The number of inbound packets (or transmission units) that contained errors preventing them from being deliverable to a higher-layer protocol.
ifOutOctets	Number of bytes transmitted since the last counter reset.
txTotalPkts	Number of transmitted packets.
ifOutDiscards ¹	Number of outbound packets which were chosen to be discarded even though no errors had been detected to prevent their transmission. A possible reason for discarding such packets could be to free up buffer space.
ifOutErrors ¹	Number of outbound packets or transmission units that could not be transmitted because of errors.
ifOutUcastPkts ²	Number of unicast packets transmitted.
ifOutMulticastPkts ²	Number of multicast packets transmitted.
ifOutBroadcastPkts ²	Number of broadcast packets transmitted.
dot3StatsAlignmentErrors ²	A count of frames received on a particular interface that are not an integral number of octets in length and do not pass the FCS check.
dot3StatsFCSErrors	A count of frames received on a particular interface that are an integral number of octets in length but do not pass the FCS check.

Table 15-21 CE-Series Ether Port PM Parameters (continued)

Parameter	Definition
dot3StatsSingleCollisionFrames ²	A count of successfully transmitted frames on a particular interface for which transmission is inhibited by exactly on collision.
dot3StatsFrameTooLong	A count of frames received on a particular interface that exceed the maximum permitted frame size.
etherStatsUndersizePkts	The total number of packets received that were less than 64 octets long (excluding framing bits, but including FCS octets) and were otherwise well formed.
etherStatsFragments	The total number of packets received that were less than 64 octets in length (excluding framing bits but including FCS octets) and had either a bad FCS with an integral number of octets (FCS Error) or a bad FCS with a nonintegral number of octets (Alignment Error). Note It is entirely normal for etherStatsFragments to increment. This is because it counts both runts (which are normal occurrences due to collisions) and noise hits.
etherStatsPkts64Octets	The total number of packets (including bad packets) received that were 64 octets in length (excluding framing bits but including FCS octets).
etherStatsPkts65to127Octets	The total number of packets (including bad packets) received that were between 65 and 127 octets in length inclusive (excluding framing bits but including FCS octets).
etherStatsPkts128to255Octets	The total number of packets (including bad packets) received that were between 128 and 255 octets in length inclusive (excluding framing bits but including FCS octets).
etherStatsPkts256to511Octets	The total number of packets (including bad packets) received that were between 256 and 511 octets in length inclusive (excluding framing bits but including FCS octets).
etherStatsPkts512to1023Octets	The total number of packets (including bad packets) received that were between 512 and 1023 octets in length inclusive (excluding framing bits but including FCS octets).
etherStatsPkts1024to1518Octets	The total number of packets (including bad packets) received that were between 1024 and 1518 octets in length inclusive (excluding framing bits but including FCS octets).
etherStatsBroadcastPkts	The total number of good packets received that were directed to the broadcast address. Note that this does not include multicast packets.
etherStatsMulticastPkts	The total number of good packets received that were directed to a multicast address. Note that this number does not include packets directed to the broadcast address.
etherStatsOversizePkts	The total number of packets received that were longer than 1518 octets (excluding framing bits, but including FCS octets) and were otherwise well formed. Note that for tagged interfaces, this number becomes 1522 bytes.
etherStatsJabbers	The total number of packets received that were longer than 1518 octets (excluding framing bits, but including FCS octets), and had either a bad FCS with an integral number of octets (FCS Error) or a bad FCS with a nonintegral number of octets (Alignment Error).

Table 15-21 CE-Series Ether Port PM Parameters (continued)

Parameter	Definition
etherStatsOctets	The total number of octets of data (including those in bad packets) received on the network (excluding framing bits but including FCS octets)
etherStatsCollisions ²	Number of transmit packets that are collisions; the port and the attached device transmitting at the same time caused collisions.
etherStatsCRCAlignErrors ²	The total number of packets received that had a length (excluding framing bits, but including FCS octets) of between 64 and 1518 octets, inclusive, but had either a bad FCS with an integral number of octets (FCS Error) or a bad FCS with a nonintegral number of octets (Alignment Error).
etherStatsDropEvents ²	Number of received frames dropped at the port level.
rxPauseFrames ¹	Number of received pause frames.
txPauseFrames ¹	Number of transmitted pause frames.
rxPktsDroppedInternalCongestion ¹	Number of received packets dropped due to overflow in frame buffer.
txPktsDroppedInternalCongestion ¹	Number of transmit queue drops due to drops in frame buffer.
rxControlFrames ¹	Number of received control frames.
mediaIndStatsRxFramesTruncated ¹	Number of received frames with length of 36 bytes or less.
mediaIndStatsRxFramesTooLong ¹	Number of received frames that are too long. The maximum is the programmed maximum frame size (for VSAN support); if the maximum frame size is set to default, then the maximum is the 2112 byte payload plus the 36 byte header, which is a total of 2148 bytes.
mediaIndStatsRxFramesBadCRC ¹	Number of received frames with CRC error.
mediaIndStatsTxFramesBadCRC ¹	Number of transmitted frames with CRC error.
mediaIndStatsRxShortPkts ¹	Number of received packets that are too small.

1. For CE1000-4 only

2. For CE100T-8 only

15.6.4.2 CE-Series Card Ether Ports Utilization Window

The Ether Ports Utilization window shows the percentage of Tx and Rx line bandwidth used by the Ethernet ports during consecutive time segments. The Utilization window provides an Interval drop-down list that enables you to set time intervals of 1 minute, 15 minutes, 1 hour, and 1 day. Line utilization is calculated with the following formulas:

$$\text{Rx} = (\text{inOctets} + \text{inPkts} * 20) * 8 / 100\% \text{ interval} * \text{maxBaseRate}$$

$$\text{Tx} = (\text{outOctets} + \text{outPkts} * 20) * 8 / 100\% \text{ interval} * \text{maxBaseRate}$$

The interval is defined in seconds. The maxBaseRate is defined by raw bits per second in one direction for the Ethernet port (that is, 1 Gbps). The maxBaseRate for CE-Series Ethernet cards is shown in [Table 15-14](#).

**Note**

Line utilization numbers express the average of ingress and egress traffic as a percentage of capacity.

15.6.4.3 CE-Series Card Ether Ports History Window

The Ethernet Ether Ports History window lists past Ethernet statistics for the previous time intervals. Depending on the selected time interval, the History window displays the statistics for each port for the number of previous time intervals as shown in [Table 15-15 on page 15-31](#). The listed parameters are defined in [Table 15-21 on page 15-44](#).

15.6.4.4 CE-Series Card POS Ports Statistics Parameters

The Ethernet POS Ports statistics window lists Ethernet POS parameters at the line level. [Table 15-22](#) defines the CE-Series Ethernet card POS Ports parameters.

Table 15-22 CE-Series Card POS Ports Parameters

Parameter	Definition
Time Last Cleared	A time stamp indicating the last time that statistics were reset.
Link Status	Indicates whether the Ethernet link is receiving a valid Ethernet signal (carrier) from the attached Ethernet device; up means present, and down means not present.
ifInOctets	Number of bytes received since the last counter reset.
rxTotalPkts	Number of received packets.
ifInDiscards ¹	The number of inbound packets that were chosen to be discarded even though no errors had been detected to prevent their being deliverable to a higher-layer protocol. One possible reason for discarding such a packet could be to free buffer space.
ifInErrors ¹	The number of inbound packets (or transmission units) that contained errors preventing them from being deliverable to a higher-layer protocol.
ifOutOctets	Number of bytes transmitted since the last counter reset.
txTotalPkts	Number of transmitted packets.
ifOutOversizePkts ¹	Packets greater than 1518 bytes transmitted out a port.
gfpStatsRxFrame ²	Number of received GFP frames.
gfpStatsTxFrame ²	Number of transmitted GFP frames.
gfpStatsRxCRCErrors	Number of packets received with a payload FCS error.
gfpStatsRxOctets ²	Number of GFP bytes received.
gfpStatsTxOctets ²	Number of GFP bytes transmitted.
gfpStatsRxSBitErrors	Sum of all the single bit errors. In the GFP CORE HDR at the GFP-T receiver, these are correctable.
gfpStatsRxMBitErrors	Sum of all the multiple bit errors. In the GFP CORE HDR at the GFP-T receiver, these are uncorrectable.
gfpStatsRxTypeInvalid	Number of receive packets dropped due to Client Data Frame UPI errors.
gfpStatsRxCIDInvalid ¹	Number of packets with invalid CID.

Table 15-22 CE-Series Card POS Ports Parameters (continued)

Parameter	Definition
gfpStatsCSFRaised	Number of GFP Client signal fail frames detected at the GFP-T receiver.
ifInPayloadCrcErrors ¹	Received payload CRC errors.
ifOutPayloadCrcErrors ¹	Transmitted payload CRC errors.
hdlcPktDrops	Number of received packets dropped before input.

1. Applicable only for CE100T-8,
2. Applicable only for CE1000-4

15.6.4.5 CE-Series Card POS Ports Utilization Window

The POS Ports Utilization window shows the percentage of Tx and Rx line bandwidth used by the POS ports during consecutive time segments. The Utilization window provides an Interval drop-down list that enables you to set time intervals of 1 minute, 15 minutes, 1 hour, and 1 day. Line utilization is calculated with the following formulas:

$$\text{Rx} = (\text{inOctets} * 8) / (\text{interval} * \text{maxBaseRate})$$

$$\text{Tx} = (\text{outOctets} * 8) / (\text{interval} * \text{maxBaseRate})$$

The interval is defined in seconds. The maxBaseRate is defined by raw bits per second in one direction for the Ethernet port (that is, 1 Gbps). The maxBaseRate for CE-Series cards is shown in [Table 15-14 on page 15-31](#).



Note

Line utilization numbers express the average of ingress and egress traffic as a percentage of capacity.

15.6.4.6 CE-Series Card POS Ports History Window

The Ethernet POS Ports History window lists past Ethernet POS ports statistics for the previous time intervals. Depending on the selected time interval, the History window displays the statistics for each port for the number of previous time intervals as shown in [Table 15-15 on page 15-31](#). The listed parameters are defined in [Table 15-22 on page 15-47](#).

15.7 Performance Monitoring for Optical Cards

This section lists PM parameters for ONS 15454 optical cards, including the OC-3, OC-12, OC-48, and OC-192 cards. [Figure 15-20](#) shows the signal types that support near-end and far-end PMs.

Figure 15-20 Monitored Signal Types for the OC-3 Cards

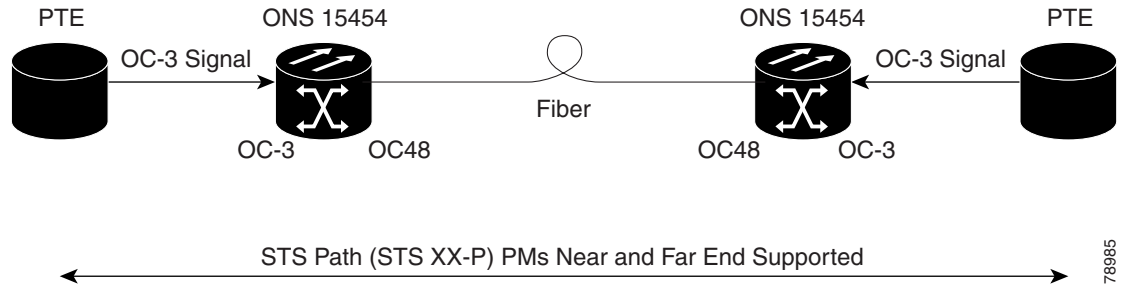

Note

The XX in Figure 15-20 represents all PMs listed in Table 15-23, Table 15-24, and Table 15-25 with the given prefix and/or suffix.

Figure 15-21 shows where overhead bytes detected on the ASICs produce PM parameters for the OC3 IR 4 SH 1310 and OC3 IR SH 1310-8 cards.

Figure 15-21 PM Read Points on the OC-3 Cards

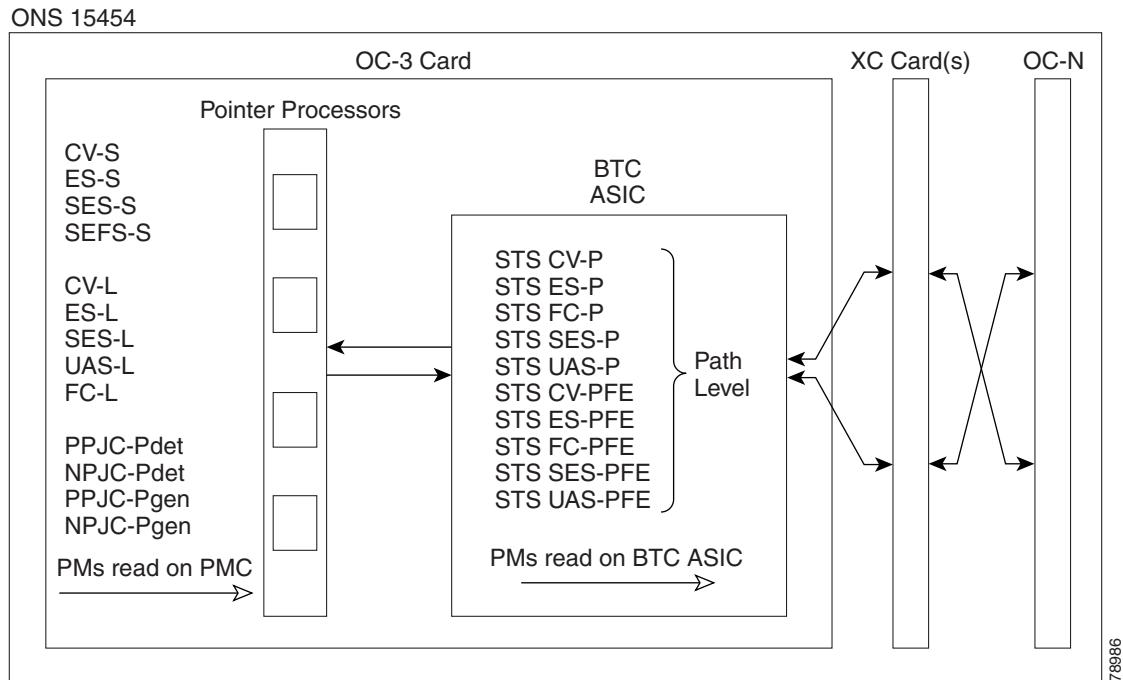

Note

For PM locations relating to protection switch counts, see the Telcordia GR-253-CORE document.

Table 15-23 and Table 15-24 list the PM parameters for OC-3 cards.

Table 15-23 OC-3 Card PMs

Section (NE)	Line (NE)	STS Path (NE)	Line (FE)	STS Path (FE) ¹
CV-S	CV-L	CV-P	CV-LFE	CV-PFE
ES-S	ES-L	ES-P	ES-LFE	ES-PFE
SES-S	SES-L	SES-P	SES-LFE	SES-PFE
SEF-S	UAS-L	UAS-P	UAS-LFE	UAS-PFE
	FC-L	FC-P	FC-LFE	FC-PFE
	PSC (1+1)	PPJC-PDET		
	PSD (1+1)	NPJC-PDET		
		PPJC-PGEN		
		NPJC-PGEN		
		PPJC-PDET-P		
		PPJC-PGEN-P		
		PJC-DIFF		

1. The STS Path (FE) PMs are valid only for the OC3-4 card on ONS 15454. Also, OC-3/12/48 on 15310MA platform, MRC-12, and OC192/STM64-XFP based cards support far-end path PM parameters. All other optical cards do not support far-end path PM parameters.

Table 15-24 OC3-8 Card PMs

Section (NE)	Line (NE)	Physical Layer (NE)	STS Path (NE)	Line (FE)	STS Path (FE)
CV-S	CV-L	LBCL	CV-P	CV-LFE	CV-PFE
ES-S	ES-L	OPT	ES-P	ES-LFE	ES-PFE
SES-S	SES-L	OPR	SES-P	SES-LFE	SES-PFE
SEF-S	UAS-L		UAS-P	UAS-LFE	UAS-PFE
	FC-L		FC-P	FC-LFE	FC-PFE
	PSC (1+1)		PPJC-PDET-P		
	PSD (1+1)		NPJC-PDET-P		
			PPJC-PGEN-P		
			NPJC-PGEN-P		
			PJCS-PDET-P		
			PJCS-PGEN-P		
			PJC-DIFF-P		

Table 15-25 lists the PM parameters for OC-12, OC-48, OC-192, and OC-192-XFP cards.

Table 15-25 OC-12, OC-48, OC-192, OC-192-XFP Card PMs

Section (NE)	Line (NE)	STS Path (NE)	Line (FE)
CV-S	CV-L	CV-P	CV-L
ES-S	ES-L	ES-P	ES-L
SES-S	SES--L	SES-P	SES-L
SEF-S	UASL	UAS-P	UAS-L
	FC-L	FC-P	FC-L
	PSC (1+1, 2F BLSR)	PPJC-PDET-P	
	PSD (1+1, 2F BLSR)	NPJC-PDET-P	
	PSC-W (4F BLSR)	PPJC-PGEN-P	
	PSD-W (4F BLSR)	NPJC-PGEN-P	
	PSC-S (4F BLSR)	PJCS-PGEN-P	
	PSD-S (4F BLSR)	PJCS-PDET-P	
	PSC-R (4F BLSR)	PJC-DIFF-P	
	PSD-R (4F BLSR)		

**Note**

If the CV-L(NE and FE) falls in a specific range, then, the user might see discrepancy in the SES and the UAS-L values. However, ES-L will be in the nearest accuracy. For a few seconds, in a given 10 seconds interval, the number of CV-L counted may not cross the CV count criteria for SES, (due to system/application limitation for the below mentioned ranges); as a consequence of which there may not be 10 continuous SES, thus UAS will not be observed. The corresponding (error) range for the line rates is as shown in [Table 15-26](#).

Table 15-26 Table of Border Error Rates

Line Rate	Error Ranges
OC3	154-164
OC12	615-625
OC48	2459-2470
OC192	9835-9845

15.8 Performance Monitoring for Optical Multirate Cards

This section lists PM parameters for the optical multirate cards MRC-12 and MRC-2.5G-4.

[Figure 15-22](#) shows where overhead bytes detected on the ASICs produce PM parameters for the MRC-12 card and the MRC-2.5G-4 card.

Figure 15-22 PM Read Points for the MRC-12 and the MRC-2.5G-4 Cards

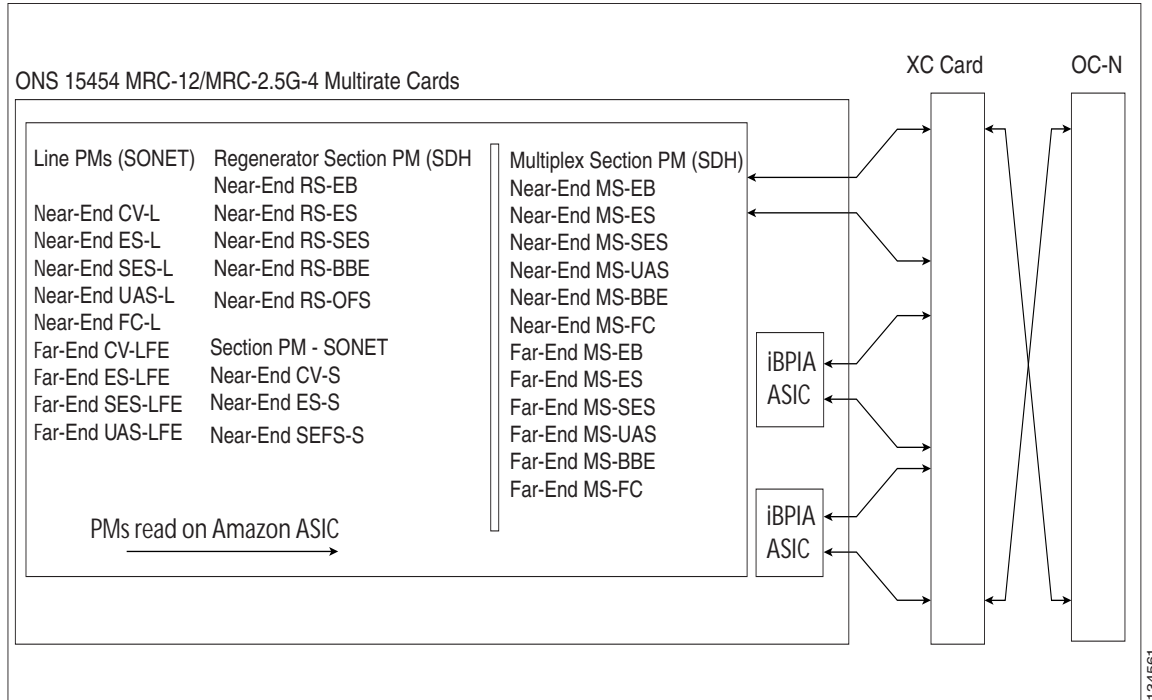

Table 15-27 lists the PM parameters for MRC-12 and MRC-4 cards.

Table 15-27 MRC Card PMs

Section (NE)	Line (NE)	Physical Layer (NE)	STS Path (NE)	Line (FE)	STS Path (FE)
CV-S	CV-L	LBC	CV-P	CV-LFE	CV-PFE
ES-S	ES-L	OPT	ES-P	ES-LFE	ES-PFE
SES-S	SES-L	OPR	SES-P	SES-LFE	SES-PFE
SEF-S	UAS-L		UAS-P	UAS-LFE	UAS-PFE
	FC-L		FC-P	FC-LFE	FC-PFE
	PSC (1+1)		PPJC-PDET-P		
	PSD (1+1)		NPJC-PDET-P		
			PPJC-PGEN-P		
			NPJC-PGEN-P		
			PJCS-PDET-P		
			PJCS-PGEN-P		
			PJC-DIFF-P		

15.9 Performance Monitoring for Storage Access Networking Cards

The following sections define PM parameters and definitions for the SAN card, also known as the FC_MR-4 or Fibre Channel card.

CTC provides FC_MR-4 performance information, including line-level parameters, port bandwidth consumption, and historical statistics. The FC_MR-4 card performance information is divided into the Statistics, Utilization, and History tabbed windows within the card view Performance tab window.

15.9.1 FC_MR-4 Statistics Window

The Statistics window lists parameters at the line level. The Statistics window provides buttons to change the statistical values shown. The Baseline button resets the displayed statistics values to zero. The Refresh button manually refreshes statistics. Auto-Refresh sets a time interval at which automatic refresh occurs. The Statistics window also has a Clear button. The Clear button sets the values on the card to zero. All counters on the card are cleared. [Table 15-28](#) defines the FC_MR-4 card statistics parameters.

Table 15-28 FC_MR-4 Card Statistics

Parameter	Definition
Time Last Cleared	Time stamp indicating the time at which the statistics were last reset.
Link Status	Indicates whether the Fibre Channel link is receiving a valid Fibre Channel signal (carrier) from the attached Fibre Channel device; up means present, and down means not present.
ifInOctets	Number of bytes received without error for the Fibre Channel payload.
rxTotalPkts	Number of Fibre Channel frames received without errors.
ifInDiscards	Number of inbound packets that were chosen to be discarded even though no errors had been detected to prevent their being deliverable to a higher-layer protocol. One possible reason for discarding such a packet could be to free up buffer space.
ifInErrors	Sum of frames that are oversized, undersized, or with cyclic redundancy check (CRC) error.
ifOutOctets	Number of bytes transmitted without error for the Fibre Channel payload.
txTotalPkts	Number of Fibre Channel frames transmitted without errors.
ifOutDiscards	Number of outbound packets which were chosen to be discarded even though no errors had been detected to prevent their transmission. A possible reason for discarding such packets could be to free up buffer space.
gfpStatsRxSBitErrors	Number of single bit errors in core header error check (CHEC).
gfpStatsRxMBitErrors	Number of multiple bit errors in CHEC.

Table 15-28 FC_MR-4 Card Statistics

Parameter	Definition
gfpStatsRxTypeInvalid	Number of invalid generic framing procedure (GFP) type field received. This includes unexpected user payload identifier (UPI) type and also errors in CHEC.
gfpStatsRxSblkCRCErrors	Number of super block CRC errors.
gfpStatsRoundTripLatencyUsec	Round trip delay for the end-to-end Fibre Channel transport in milli seconds.
gfpStatsRxDistanceExtBuffers	Number of buffer credit received for GFP-T receiver (valid only if distance extension is enabled).
gfpStatsTxDistanceExtBuffers	Number of buffer credit transmitted for GFP-T transmitter (valid only if distance extension is enabled).
mediaIndStatsRxFramesTruncated	Number of Fibre Channel frames received with frame size <= 36 bytes.
mediaIndStatsRxFramesTooLong	Number of Fibre Channel frames received with frame size higher than the provisioned maximum frame size.
mediaIndStatsRxFramesBadCRC	Number of Fibre Channel frames received with bad CRC.
mediaIndStatsTxFramesBadCRC	Number of Fibre Channel frames transmitted with bad CRC.
fcStatsLinkRecoveries	Number of link recoveries.
fcStatsRxCredits	Number of buffers received to buffer credits T (valid only if distance extension is enable).
fcStatsTxCredits	Number of buffers transmitted to buffer credits T (valid only if distance extension is enable).
fcStatsZeroTxCredits	Number of transmit attempts that failed because of unavailable credits.
8b10bInvalidOrderedSets	8b10b loss of sync count on Fibre Channel line side.
8b10bStatsEncodingDispErrors	8b10b disparity violations count on Fibre Channel line side.
gfpStatsCSFRaised	Number of GFP Client Signal Fail frames detected.

15.9.2 FC_MR-4 Utilization Window

The Utilization window shows the percentage of Tx and Rx line bandwidth used by the ports during consecutive time segments. The Utilization window provides an Interval drop-down list that enables you to set time intervals of 1 minute, 15 minutes, 1 hour, and 1 day. Line utilization is calculated with the following formulas:

$$Rx = (\text{inOctets} + \text{inPkts} * 24) * 8 / 100\% \text{ interval} * \text{maxBaseRate}$$

$$Tx = (\text{outOctets} + \text{outPkts} * 24) * 8 / 100\% \text{ interval} * \text{maxBaseRate}$$

The interval is defined in seconds. The maxBaseRate is defined by raw bits per second in one direction for the port (that is, 1 Gbps or 2 Gbps). The maxBaseRate for FC_MR-4 cards is shown in [Table 15-29](#).

Table 15-29 *maxBaseRate for STS Circuits*

STS	maxBaseRate
STS-24	850000000
STS-48	850000000 x 2 ¹

1. For 1 Gbps of bit rate being transported, there are only 850 Mbps of actual data because of 8b->10b conversion. Similarly, for 2 Gbps of bit rate being transported, there are only 1700 Mbps (850 Mbps x 2) of actual data.



Note

Line utilization numbers express the average of ingress and egress traffic as a percentage of capacity.

15.9.3 FC_MR-4 History Window

The History window lists past FC_MR-4 statistics for the previous time intervals. Depending on the selected time interval, the History window displays the statistics for each port for the number of previous time intervals as shown in [Table 15-30](#). The listed parameters are defined in [Table 15-28 on page 15-53](#).

Table 15-30 *FC_MR-4 History Statistics per Time Interval*

Time Interval	Number of Intervals Displayed
1 minute	60 previous time intervals
15 minutes	32 previous time intervals
1 hour	24 previous time intervals
1 day (24 hours)	7 previous time intervals

