



Performance Monitoring



Note

The terms "Unidirectional Path Switched Ring" and "UPSR" may appear in Cisco literature. These terms do not refer to using Cisco ONS 15xxx products in a unidirectional path switched ring configuration. Rather, these terms, as well as "Path Protected Mesh Network" and "PPMN," refer generally to Cisco's path protection feature, which may be used in any topological network configuration. Cisco does not recommend using its path protection feature in any particular topological network configuration.

Performance monitoring (PM) parameters are used by service providers to gather, store, set thresholds, and report performance data for early detection of problems. In this chapter, PM parameters and concepts are defined for electrical cards, Ethernet cards, optical cards, and DWDM cards in the Cisco ONS 15454.

For information about enabling and viewing PM values, refer to the *Cisco ONS 15454 Procedure Guide*.

Chapter topics include:

- [Threshold Performance Monitoring, page 1](#)
- [Intermediate Path Performance Monitoring, page 2](#)
- [Pointer Justification Count Performance Monitoring, page 3](#)
- [DS-1 Facility Data Link Performance Monitoring, page 3](#)
- [Performance Monitoring for Electrical Cards, page 4](#)
- [Performance Monitoring for Ethernet Cards, page 29](#)
- [Performance Monitoring for Optical Cards, page 35](#)
- [Performance Monitoring for DWDM Cards, page 65](#)



Note

For additional information regarding PM parameters, refer to Telcordia documents GR-1230-CORE, GR-820-CORE, GR-499-CORE, and GR-253-CORE documents and the ANSI document entitled *Digital Hierarchy - Layer 1 In-Service Digital Transmission Performance Monitoring*.

15.1 Threshold Performance Monitoring

Thresholds are used to set error levels for each PM parameter. You can set individual PM threshold values from the Cisco Transport Controller (CTC) card view Provisioning tab. For procedures on provisioning card thresholds, such as line, path, and SONET thresholds, refer to the *Cisco ONS 15454 Procedure Guide*.

During the accumulation cycle, if the current value of a performance monitoring parameter reaches or exceeds its corresponding threshold value, a threshold crossing alert (TCA) is generated by the node and displayed by CTC. TCAs provide early detection of performance degradation. When a threshold is crossed, the node continues to count the errors during a given accumulation period. If 0 is entered as the threshold value, the performance monitoring parameter is disabled.

Change the threshold if the default value does not satisfy your error monitoring needs. For example, customers with a critical DS-1 installed for 911 calls must guarantee the best quality of service on the line; therefore, they lower all thresholds so that the slightest error raises a TCA.

15.2 Intermediate Path Performance Monitoring

Intermediate path performance monitoring (IPPM) allows transparent monitoring of a constituent channel of an incoming transmission signal by a node that does not terminate that channel. Many large ONS 15454 networks only use line terminating equipment (LTE) not path terminating equipment (PTE). Table 15-1 shows ONS 15454 cards that are considered LTEs.

Table 15-1 Line Terminating Equipment

Electrical LTE	
EC1-12	DS1-14
DS1N-14	DS3-12
DS3N-12	DS3-12E
DS3N-12E	DS3XM-6
Optical LTE	
OC3 IR 4/STM1 SH 1310	OC3 IR/STM1 SH 1310-8
OC12 IR/STM4 SH1310	OC12 LR/STM4 LH1310
OC12 LR/STM4 LH 1550	OC12 IR/STM4 SH 1310-4
OC48 IR 1310	OC48 LR 1550
OC48 IR/STM16 SH AS 1310	OC48 LR/STM16 LH AS 1550
OC48 ELR/STM16 EH 100 GHz	OC48 ELR 200 GHz
OC192 SR/STM64 IO 1310	OC192 IR/STM64 SH 1550
OC192 LR/STM64 LH 1550	OC192 LR/STM64 LH ITU 15xx.xx
TXP_MR_10G	MXP_2.5G_10G

Software R3.0 and higher allows LTE cards to monitor near-end PM data on individual STS payloads by enabling IPPM. After enabling IPPM provisioning on the line card, service providers can monitor large amounts of STS traffic through intermediate nodes, thus making troubleshooting and maintenance activities more efficient.

IPPM occurs only on STS paths that have IPPM enabled, and TCAs are raised only for PM parameters on the IPPM enabled paths. The monitored IPPM parameters are STS CV-P, STS ES-P, STS SES-P, STS UAS-P, and STS FC-P.

**Note**

Far-end IPPM is not supported. However, SONET path PMs can be monitored by logging into the far-end node directly.

The ONS 15454 performs IPPM by examining the overhead in the monitored path and by reading all of the near-end path PM values in the incoming direction of transmission. The IPPM process allows the path signal to pass bidirectionally through the node completely unaltered.

For detailed information about specific IPPM parameters, locate the card name in the following sections and review the appropriate definition.

15.3 Pointer Justification Count Performance Monitoring

Pointers are used to compensate for frequency and phase variations. Pointer justification counts indicate timing errors on SONET networks. When a network is out of sync, jitter and wander occur on the transported signal. Excessive wander can cause terminating equipment to slip.

Slips cause different effects in service. Voice service has intermittent audible clicks. Compressed voice technology has short transmission errors or dropped calls. Fax machines lose scanned lines or experience dropped calls. Digital video transmission has distorted pictures or frozen frames. Encryption service loses the encryption key causing data to be transmitted again.

Pointers provide a way to align the phase variations in STS and VT payloads. The STS payload pointer is located in the H1 and H2 bytes of the line overhead. Clocking differences are measured by the offset in bytes from the pointer to the first byte of the STS synchronous payload envelope (SPE) called the J1 byte. Clocking differences that exceed the normal range of 0 to 782 can cause data loss.

There are positive (PPJC) and negative (NPJC) pointer justification count parameters. PPJC is a count of path-detected (PPJC-Pdet) or path-generated (PPJC-Pgen) positive pointer justifications. NPJC is a count of path-detected (NPJC-Pdet) or path-generated (NPJC-Pgen) negative pointer justifications depending on the specific PM name.

A consistent pointer justification count indicates clock synchronization problems between nodes. A difference between the counts means the node transmitting the original pointer justification has timing variations with the node detecting and transmitting this count. Positive pointer adjustments occur when the frame rate of the SPE is too slow in relation to the rate of the STS 1.

You must enable PPJC and NPJC performance monitoring parameters for LTE cards. See Table 15-1 on page 15-2 for a list of Cisco ONS 15454 LTE cards. On CTC, the count fields for PPJC and NPJC PMs appear white and blank unless they are enabled on the card view Provisioning tab.

For detailed information about specific pointer justification count PM parameters, locate the card name in the following sections and review the appropriate definition.

15.4 DS-1 Facility Data Link Performance Monitoring

Facility Data Link (FDL) performance monitoring enables the DS1N-14 card to calculate and report DS-1 error rate performance measured at both the near-end and far-end of the FDL. The far-end information is reported as received on the FDL in a performance report message (PRM) from an intelligent channel service unit (CSU).

To monitor DS-1 FDL PM values, the DS-1 must be set to use extended superframe (ESF) format and the FDL must be connected to an intelligent CSU. For procedures on provisioning ESF on the DS1N-14 card, refer to the *Cisco ONS 15454 Procedure Guide*.

The monitored DS-1 FDL PM parameters are CV-PFE, ES-PFE, ESA-PFE, ESB-PFE, SES-PFE, SEFS-PFE, CSS-PFE, UAS-PFE, FC-PFE, and ES-LFE. For detailed information about specific DS-1 FDL PM parameters, locate the DS1N-14 card name in the following sections and review the appropriate definition.

15.5 Performance Monitoring for Electrical Cards

The following sections define performance monitoring parameters for the EC1-12, DS1-14, DS1N-14, DS3-12, DS3N-12, DS3-12E, DS3N-12E, and DS3XM-6 electrical cards.

15.5.1 EC1-12 Card Performance Monitoring Parameters

Figure 15-1 shows signal types that support near-end and far-end PMs. [Figure 15-2 on page 15-5](#) shows where overhead bytes detected on the application specific integrated circuits (ASICs) produce performance monitoring parameters for the EC1-12 card.

Figure 15-1 Monitored Signal Types for the EC1-12 Card

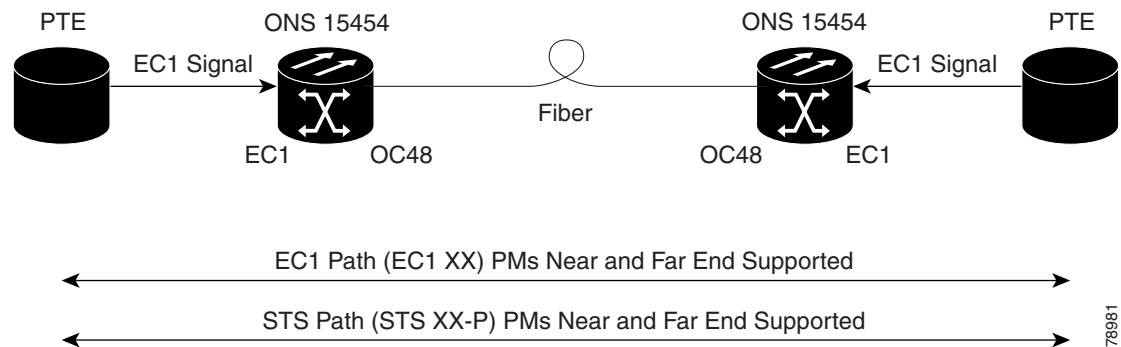

Note

The XX in Figure 15-1 represents all PMs listed in Table 15-2 on page 15-5 through Table 15-7 on page 15-8 with the given prefix and/or suffix.

Figure 15-2 PM Read Points on the EC1-12 Card

ONS 15454

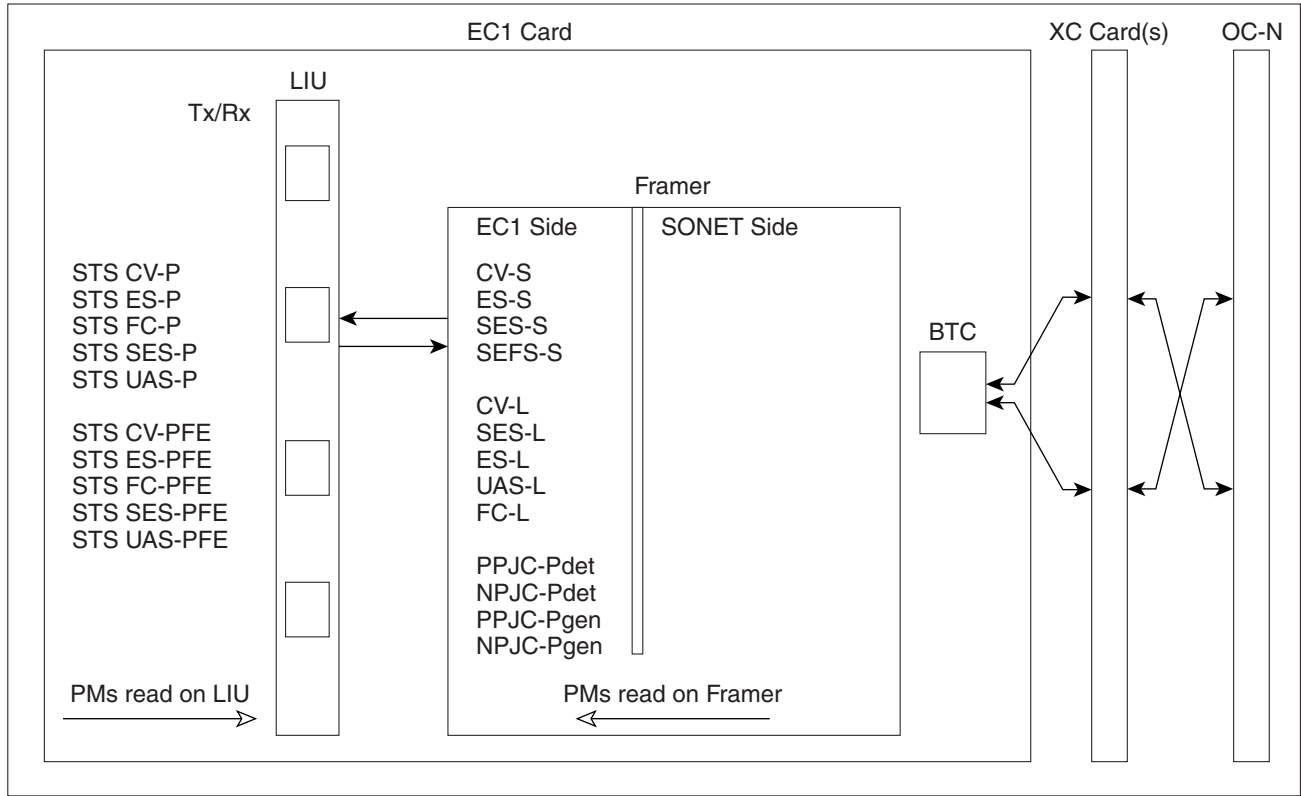

Note

SONET path PMs do not count unless IPPM is enabled. See the “Intermediate Path Performance Monitoring” section on page 2.

The PM parameters for the EC1-12 cards are described in Table 15-2 through Table 15-7 on page 15-8.

Table 15-2 Near-End Section PMs for the EC1-12 Card

Parameter	Definition
CV-S	Section Coding Violation (CV-S) is a count of BIP errors detected at the section-layer (that is, using the B1 byte in the incoming SONET signal). Up to eight section BIP errors can be detected per STS-N frame; each error increments the current CV-S second register.
ES-S	Section Errored Seconds (ES-S) is a count of the number of seconds when at least one section-layer BIP error was detected or an SEF or loss of signal (LOS) defect was present.

Table 15-2 Near-End Section PMs for the EC1-12 Card (continued)

Parameter	Definition
SES-S	Section Severely Errored Seconds (SES-S) is a count of the seconds when K (see GR-253-CORE for value) or more section-layer BIP errors were detected or a severely errored frame (SEF) or LOS defect was present.
SEFS-S	Section Severely Errored Framing Seconds (SEFS-S) is a count of the seconds when an SEF defect was present. An SEF defect is expected during most seconds where an LOS or loss of frame (LOF) defect is present. However, there may be situations when that is not the case, and the SEFS-S parameter is only incremented based on the presence of the SEF defect.

Table 15-3 Near-End Line Layer PMs for the EC1-12 Card

Parameter	Definition
CV-L	Near-End Line Code Violation (CV-L) is a count of BIP errors detected at the line-layer (that is, using the B2 bytes in the incoming SONET signal). Up to 8 x N BIP errors can be detected per STS-N frame, with each error incrementing the current CV-L second register.
ES-L	Near-End Line Errored Seconds (ES-L) is a count of the seconds when at least one line-layer BIP error was detected or an alarm indication signal-line (AIS-L) defect was present.
SES-L	Near-End Line Severely Errored Seconds (SES-L) is a count of the seconds when K (see GR-253 for values) or more line-layer BIP errors were detected or an AIS-L defect was present.
UAS-L	Near-End Line Unavailable Seconds (UAS-L) is a count of the seconds when the line is unavailable. A line becomes unavailable when ten consecutive seconds occur that qualify as SES-Ls, and the line continues to be unavailable until ten consecutive seconds occur that do not qualify as SES-Ls.
FC-L	Near-End Line Failure Count (FC-L) is a count of the number of near-end line failure events. A failure event begins when an AIS-L failure or a lower-layer, traffic-related, near-end failure is declared. This failure event ends when the failure is cleared. A failure event that begins in one period and ends in another period is counted only in the period where it begins.

Table 15-4 Near-End SONET Path PMs for the EC1-12 Card

Parameter	Definition
Note	SONET path PMs do not count unless IPPM is enabled. See the “Intermediate Path Performance Monitoring” section on page 2.
STS CV-P	Near-End STS Path Coding Violations (CV-P) is a count of BIP errors detected at the STS path layer (that is, using the B3 byte). Up to eight BIP errors can be detected per frame; each error increments the current CV-P second register.

Table 15-4 Near-End SONET Path PMs for the EC1-12 Card (continued)

Parameter	Definition
STS ES-P	Near-End STS Path Errored Seconds (ES-P) is a count of the seconds when at least one STS path BIP error was detected. STS ES-P can also be caused by an AIS-P defect (or a lower-layer, traffic-related, near-end defect) or an LOP-P defect.
STS FC-P	Near-End STS Path Failure Counts (FC-P) is a count of the number of near-end STS path failure events. A failure event begins when an AIS-P failure, an LOP-P failure, an unequipped path (UNEQ-P) or a trace identifier mismatch (TIM-P) failure is declared. A failure event also begins if the STS PTE monitoring the path supports ERDI-P for that path. The failure event ends when these failures are cleared.
STS SES-P	Near-End STS Path Severely Errored Seconds (SES-P) is a count of the seconds when K (2400) or more STS path BIP errors were detected. STS SES-P can also be caused by an AIS-P defect (or a lower-layer, traffic-related, near-end defect) or an LOP-P defect.
STS UAS-P	Near-End STS Path Unavailable Seconds (UAS-P) is a count of the seconds when the STS path was unavailable. An STS path becomes unavailable when ten consecutive seconds occur that qualify as SES-Ps, and it continues to be unavailable until ten consecutive seconds occur that do not qualify as SES-Ps.

Table 15-5 Near-End SONET Path BIP PMs for the EC1-12 Card

Parameter	Definition
Note	On CTC, the count fields for PPJC and NPJC PMs appear white and blank unless they are enabled on the card view Provisioning tab.
PPJC-Pdet	Positive Pointer Justification Count, STS Path Detected (PPJC-Pdet) is a count of the positive pointer justifications detected on a particular path in an incoming SONET signal.
NPJC-Pdet	Negative Pointer Justification Count, STS Path Detected (NPJC-Pdet) is a count of the negative pointer justifications detected on a particular path in an incoming SONET signal.
PPJC-Pgen	Positive Pointer Justification Count, STS Path Generated (PPJC-Pgen) is a count of the positive pointer justifications generated for a particular path to reconcile the frequency of the SPE with the local clock.
NPJC-Pgen	Negative Pointer Justification Count, STS Path Generated (NPJC-Pgen) is a count of the negative pointer justifications generated for a particular path to reconcile the frequency of the synchronous payload envelope (SPE) with the local clock.

Table 15-6 Far-End Line Layer PMs for the EC1-12 Card

Parameter	Definition
CV-L	Far-End Line Code Violation (CV-L) is a count of BIP errors detected by the far-end LTE and reported back to the near-end LTE using the REI-L indication in the line overhead. For SONET signals at rates below OC-48, up to 8 x N BIP errors per STS-N frame can be indicated using the REI-L. For OC-48 signals, up to 255 BIP errors per STS-N frame can be indicated. The current CV-L second register is incremented for each BIP error indicated by the incoming REI-L.
ES-L	Far-End Line Errored Seconds (ES-L) is a count of the seconds when at least one line-layer BIP error was reported by the far-end LTE or an RDI-L defect was present.
SES-L	Far-End Line Severely Errored Seconds (SES-L) is a count of the seconds when K (see GR-253-CORE for values) or more line-layer BIP errors were reported by the far-end LTE or an RDI-L defect was present.
UAS-L	Far-End Line Unavailable Seconds (UAS-L) is a count of the seconds when the line is unavailable at the far end. A line becomes unavailable at the far end when ten consecutive seconds occur that qualify as SES-LFEs and it continues to be unavailable until ten consecutive seconds occur that do not qualify as SES-LFEs.
FC-L	Far-End Line Failure Count (FC-L) is a count of the number of far-end line failure events. A failure event begins when RFI-L failure is declared, and it ends when the RFI-L failure clears. A failure event that begins in one period and ends in another period is counted only in the period where it began.

Table 15-7 Far-End SONET Path PMs for the EC1-12 Card

Parameter	Definition
Note	SONET path PMs do not count unless IPPM is enabled. See the “Intermediate Path Performance Monitoring” section on page 2.
STS CV-PFE	Far-End STS Path Coding Violations (CV-PFE) is a count of BIP errors detected at the STS path layer (that is, using the B3 byte). Up to eight BIP errors can be detected per frame; each error increments the current CV-PFE second register.
STS ES-PFE	Far-End STS Path Errored Seconds (ES-PFE) is a count of the seconds when at least one STS path BIP error was detected. STS ES-PFE can also be caused by an AIS-P defect (or a lower-layer, traffic-related, far-end defect) or an LOP-P defect.
STS FC-PFE	Far-End STS Path Failure Counts (FC-PFE) is a count of the number of far-end STS path failure events. A failure event begins when an AIS-P failure, an LOP-P failure, an unequipped path (UNEQ-P) or a trace identifier mismatch (TIM-P) failure is declared. A failure event also begins if the STS PTE monitoring the path supports ERDI-P for that path. The failure event ends when these failures are cleared.

Table 15-7 Far-End SONET Path PMs for the EC1-12 Card (continued)

Parameter	Definition
STS SES-PFE	Far-End STS Path Severely Errored Seconds (SES-P) is a count of the seconds when K (2400) or more STS path BIP errors were detected. STS SES-PFE can also be caused by an AIS-P defect (or a lower-layer, traffic-related, far-end defect) or an LOP-P defect.
STS UAS-PFE	Far-End STS Path Unavailable Seconds (UAS-PFE) is a count of the seconds when the STS path was unavailable. An STS path becomes unavailable when ten consecutive seconds occur that qualify as SES-PFEs, and it continues to be unavailable until ten consecutive seconds occur that do not qualify as SES-PFEs.

15.5.2 DS1-14 and DS1N-14 Card Performance Monitoring Parameters

Figure 15-3 shows the signal types that support near-end and far-end PMs. Figure 15-4 on page 15-10 shows where overhead bytes detected on the ASICs produce performance monitoring parameters for the DS1-14 and DS1N-14 cards.

Figure 15-3 Monitored Signal Types for the DS1-14 and DS1N-14 Cards

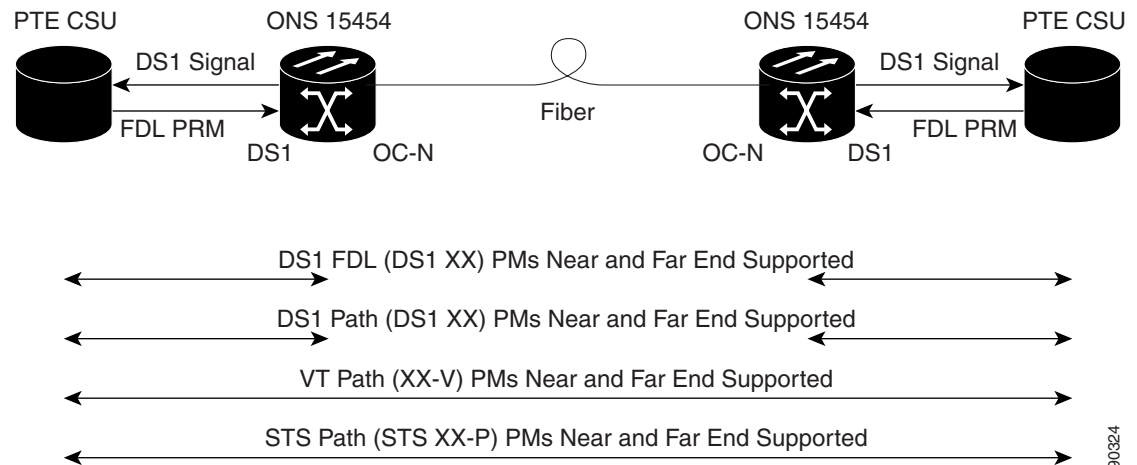
**Note**

The XX in Figure 15-3 represents all PMs listed in Table 15-8 on page 15-10 through Table 15-15 on page 15-15 with the given prefix and/or suffix.

Figure 15-4 PM Read Points on the DS1-14 and DS1N-14 Cards

ONS 15454

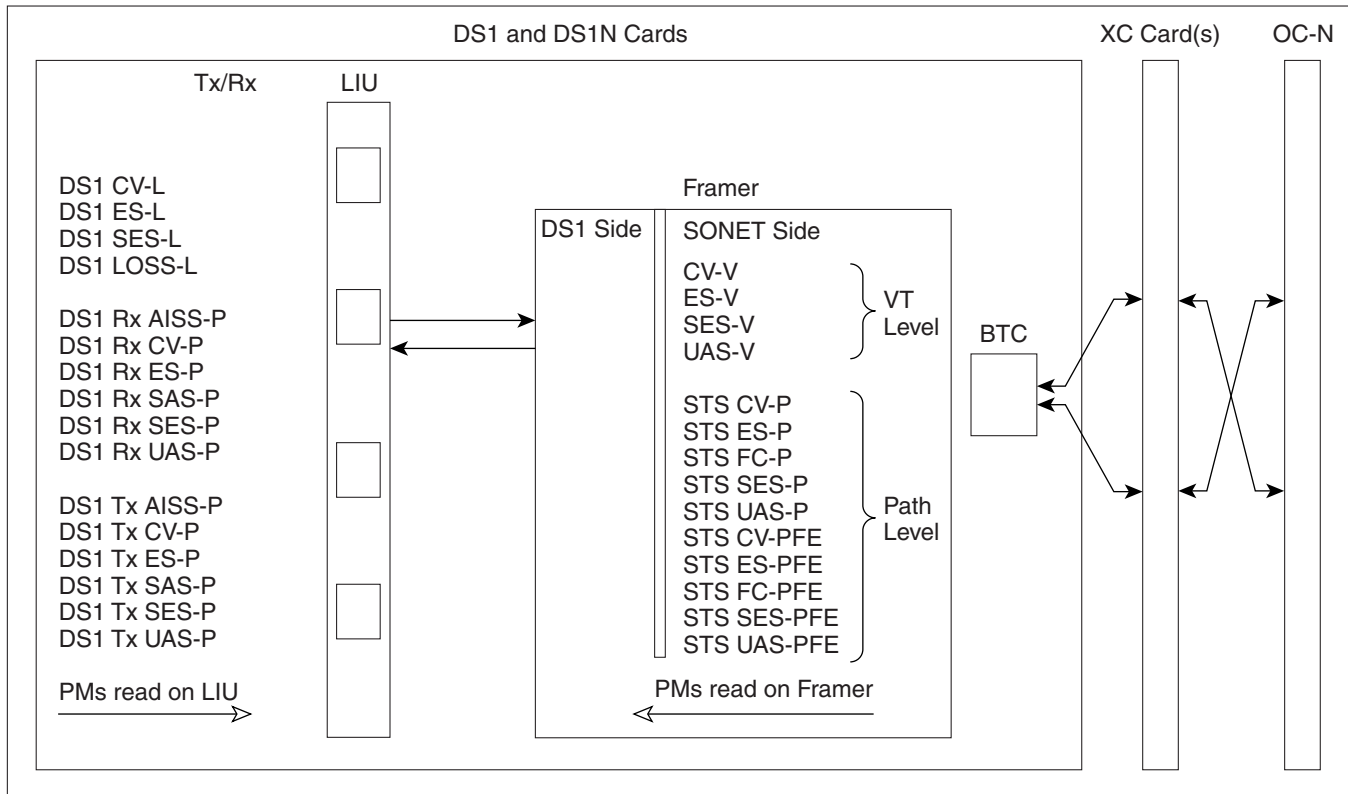

The PM parameters for the DS1-14 and DS1N-14 cards are described in Table 15-8 through Table 15-15 on page 15-15.

Table 15-8 DS-1 Line PMs for the DS1-14 and DS1N-14 Cards

Parameter	Definition
DS1 CV-L	Line Code Violation (CV-L) indicates the number of coding violations occurring on the line. This parameter is a count of bipolar violations (BPVs) and excessive zeros (EXZs) occurring over the accumulation period.
DS1 ES-L	Line Errored Seconds (ES-L) is a count of the seconds containing one or more anomalies (BPV + EXZ) and/or defects (loss of signal) on the line.
DS1 SES-L	Line Severely Errored Seconds (SES-L) is a count of the seconds containing more than a particular quantity of anomalies (BPV + EXZ \geq 1544) and/or defects on the line.
DS1 LOSS-L	Line Loss of Signal Seconds (LOSS-L) is a count of one-second intervals containing one or more LOS defects.

Table 15-9 DS-1 Receive Path PMs for the DS1-14 and DS1N-14 Cards

Parameter	Definition
Note	Under the Provisioning > Threshold tab, the DS1-14 and DS1N-14 cards have user-defined thresholds for the DS1 receive (Rx) path PMs. In the Threshold tab they are displayed as CV, ES, SES, UAS, AISS, and SAS without the Rx prefix.
DS1 Rx AISS-P	Receive Path Alarm Indication Signal (Rx AIS-P) means an alarm indication signal occurred on the receive end of the path. This parameter is a count of seconds containing one or more AIS defects.
DS1 Rx CV-P	Receive Path Code Violation (Rx CV-P) means a coding violation occurred on the receive end of the path. For DS1-ESF paths, this parameter is a count of detected CRC-6 errors. For the DS1-SF paths, the Rx CV-P parameter is a count of detected frame bit errors (FE).
DS1 Rx ES-P	Receive Path Errored Seconds (Rx ES-P) is a count of the seconds containing one or more anomalies and/or defects for paths on the receive end of the signal. For DS1-ESF paths, this parameter is a count of one-second intervals containing one or more CRC-6 errors, or one or more CS events, or one or more SEF or AIS defects. For DS1-SF paths, the Rx ES-P parameter is a count of one-second intervals containing one or more FE events, or one or more CS events, or one or more SEF or AIS defects.
DS1 Rx SAS-P	Receive Path Severely Errored Seconds Frame/Alarm Indication Signal (Rx SAS-P) is a count of one-second intervals containing one or more SEFs or one or more AIS defects on the receive end of the signal.
DS1 Rx SES-P	Receive Path Severely Errored Seconds (Rx SES-P) is a count of the seconds containing more than a particular quantity of anomalies and/or defects for paths on the receive end of the signal. For the DS1-ESF paths, this parameter is a count of seconds when 320 or more CRC-6 errors or one or more SEF or AIS defects occurred. For DS1-SF paths, an SES is a second containing either the occurrence of four FEs or one or more SEF or AIS defects.
DS1 Rx UAS-P	Receive Path Unavailable Seconds (Rx UAS-P) is a count of one-second intervals when the DS-1 path is unavailable on the receive end of the signal. The DS-1 path is unavailable when ten consecutive SESs occur. The ten SESs are included in unavailable time. Once unavailable, the DS-1 path becomes available when ten consecutive seconds occur with no SESs. The ten seconds with no SESs are excluded from unavailable time.

Table 15-10 DS-1 Transmit Path PMs for the DS1-14 and DS1N-14 Cards

Parameter	Definition
Note	Under the Performance tab, the displayed DS-1 Tx path PM values are based on calculations performed by the card and therefore have no user-defined thresholds.
DS1 Tx AISS-P	Transmit Path Alarm Indication Signal (Tx AIS-P) means an alarm indication signal occurred on the transmit end of the path. This parameter is a count of seconds containing one or more AIS defects.

Table 15-10 DS-1 Transmit Path PMs for the DS1-14 and DS1N-14 Cards (continued)

Parameter	Definition
DS1 Tx CV-P	Transmit Path Code Violation (Tx CV-P) means a coding violation occurred on the transmit end of the path. For DS1-ESF paths, this parameter is a count of detected CRC-6 errors. For the DS1-SF paths, the Tx CV-P parameter is a count of detected FEs.
DS1 Tx ES-P	Transmit Path Errored Seconds (Tx ES-P) is a count of the seconds containing one or more anomalies and/or defects for paths on the transmit end of the signal. For DS1-ESF paths, this parameter is a count of one-second intervals containing one or more CRC-6 errors, or one or more CS events, or one or more SEF or AIS defects. For DS1-SF paths, the Tx ES-P parameter is a count of one-second intervals containing one or more FE events, or one or more CS events, or one or more SEF or AIS defects.
DS1 Tx SAS-P	Transmit Path Severely Errored Seconds Frame/Alarm Indication Signal (Tx SAS-P) is a count of one-second intervals containing one or more SEFs or one or more AIS defects on the receive end of the signal.
DS1 Tx SES-P	Transmit Path Severely Errored Seconds (Tx SES-P) is a count of the seconds containing more than a particular quantity of anomalies and/or defects for paths on the transmit end of the signal. For the DS1-ESF paths, this parameter is a count of seconds when 320 or more CRC-6 errors or one or more SEF or AIS defects occurred. For DS1-SF paths, an SES is a second containing either the occurrence of four FEs or one or more SEF or AIS defects.
DS1 Tx UAS-P	Transmit Path Unavailable Seconds (Tx UAS-P) is a count of one-second intervals when the DS-1 path is unavailable on the transmit end of the signal. The DS-1 path is unavailable when ten consecutive SESs occur. The ten SESs are included in unavailable time. Once unavailable, the DS-1 path becomes available when ten consecutive seconds occur with no SESs. The ten seconds with no SESs are excluded from unavailable time.

Table 15-11 VT Path PMs for the DS1-14 and DS1N-14 Cards

Parameter	Definition
CV-V	Code Violation VT Layer (CV-V) is a count of the BIP errors detected at the VT path layer. Up to two BIP errors can be detected per VT superframe, with each error incrementing the current CV-V second register.
ES-V	Errored Seconds VT Layer (ES-V) is a count of the seconds when at least one VT Path BIP error was detected. An AIS-V defect (or a lower-layer, traffic-related, near-end defect) or an LOP-V defect can also cause an ES-V.

Table 15-11 VT Path PMs for the DS1-14 and DS1N-14 Cards (continued)

Parameter	Definition
SES-V	Severely Errored Seconds VT Layer (SES-V) is a count of seconds when K (600) or more VT Path BIP errors were detected. SES-V can also be caused by an AIS-V defect (or a lower-layer, traffic-related, near-end defect) or an LOP-V defect.
UAS-V	Unavailable Second VT Layer (UAS-V) is a count of the seconds when the VT path was unavailable. A VT path becomes unavailable when ten consecutive seconds occur that qualify as SES-Vs, and it continues to be unavailable until ten consecutive seconds occur that do not qualify as SES-Vs.

Table 15-12 Near-End SONET Path PMs for the DS1-14 and DS1N-14 Cards

Parameter	Definition
STS CV-P	Near-End STS Path Coding Violations (CV-P) is a count of BIP errors detected at the STS path layer (that is, using the B3 byte). Up to eight BIP errors can be detected per frame, with each error incrementing the current CV-P second register.
STS ES-P	Near-End STS Path Errored Seconds (ES-P) is a count of the seconds when at least one STS path BIP error was detected. An AIS-P defect (or a lower-layer, traffic-related, near-end defect) or an LOP-P defect can also cause an STS ES-P.
STS FC-P	Near-End STS Path Failure Counts (FC-P) is a count of the number of near-end STS path failure events. A failure event begins when an AIS-P failure, an LOP-P failure, a UNEQ-P, or a TIM-P failure is declared. A failure event also begins if the STS PTE that is monitoring the path supports ERDI-P for that path. The failure event ends when these failures are cleared.
STS SES-P	Near-End STS Path Severely Errored Seconds (SES-P) is a count of the seconds when K (2400) or more STS path BIP errors were detected. An AIS-P defect (or a lower-layer, traffic-related, near-end defect) or an LOP-P defect can also cause an STS SES-P.
STS UAS-P	Near-End STS Path Unavailable Seconds (UAS-P) is a count of the seconds when the STS path was unavailable. An STS path becomes unavailable when ten consecutive seconds occur that qualify as SES-Ps, and it continues to be unavailable until ten consecutive seconds occur that do not qualify as SES-Ps.

Table 15-13 Far-End SONET Path PMs for the DS1-14 and DS1N-14 Cards

Parameter	Definition
STS CV-PFE	Far-End STS Path Coding Violations (CV-PFE) is a count of BIP errors detected at the STS path layer (that is, using the B3 byte). Up to eight BIP errors can be detected per frame, with each error incrementing the current CV-PFE second register.
STS ES-PFE	Far-End STS Path Errored Seconds (ES-PFE) is a count of the seconds when at least one STS path BIP error was detected. An AIS-P defect (or a lower-layer, traffic-related, far-end defect) or an LOP-P defect can also cause an STS ES-PFE.
STS FC-PFE	Far-End STS Path Failure Counts (FC-PFE) is a count of the number of far-end STS path failure events. A failure event begins when an AIS-P failure, an LOP-P failure, a UNEQ-P, or a TIM-P failure is declared. A failure event also begins if the STS PTE that is monitoring the path supports ERDI-P for that path. The failure event ends when these failures are cleared.
STS SES-PFE	Far-End STS Path Severely Errored Seconds (SES-PFE) is a count of the seconds when K (2400) or more STS path BIP errors were detected. An AIS-P defect (or a lower-layer, traffic-related, far-end defect) or an LOP-P defect can also cause an STS SES-PFE.
STS UAS-PFE	Far-End STS Path Unavailable Seconds (UAS-PFE) is a count of the seconds when the STS path was unavailable. An STS path becomes unavailable when ten consecutive seconds occur that qualify as SES-PFEs, and it continues to be unavailable until ten consecutive seconds occur that do not qualify as SES-PFEs.

Table 15-14 Far-End VT Path PMs for the DS1-14 and DS1N-14 Cards

Parameter	Definition
CV-VFE	Far-End VT Path Coding Violations (CV-VFE) is a count of the number of BIP errors detected by the far-end VT path terminating equipment (PTE) and reported back to the near-end VT PTE using the REI-V indication in the VT path overhead. Only one BIP error can be indicated per VT superframe using the REI-V bit. The current CV-VFE second register is incremented for each BIP error indicated by the incoming REI-V.
ES-VFE	Far-End VT Path Errored Seconds (ES-VFE) is a count of the seconds when at least one VT path BIP error was reported by the far-end VT PTE, or a one-bit RDI-V defect was present.
SES-VFE	Far-End VT Path Severely Errored Seconds (SES-VFE) is a count of the seconds when K (600) or more VT path BIP errors were reported by the far-end VT PTE or a one-bit RDI-V defect was present.
UAS-VFE	Far-End VT Path Unavailable Seconds (UAS-VFE) is a count of the seconds when the VT path is unavailable at the far-end. A VT path is unavailable at the far-end when ten consecutive seconds occur that qualify as SES-VFEs.

Table 15-15 DS-1 FDL PMs for the Near-End or Far-End DS1N-14 Card

Parameter	Definition
DS1 Rx CSS-P	Received FDL Path Controlled Slip Seconds (Rx CSS-P) is a count of the seconds when at least one FDL path slipped seconds error was reported by the far-end FDL PTE.
DS1 Rx ESA-P	Received FDL Path Errored Seconds type A (RX ESA-P) is a count of the seconds when at least one FDL path BIP error type A was reported by the far-end FDL PTE.
DS1 Rx ESB-P	Received FDL Path Errored Seconds type B (Rx ESB-P) is a count of the seconds when at least one FDL path BIP error type B was reported by the far-end FDL PTE.
DS1 Rx SEFS-P	Received FDL Path Severely Errored Frame Seconds (RX SEFS-P) is a count of the seconds when at least one or more severely errored frames were reported by the far-end FDL PTE.

15.5.3 DS3-12 and DS3N-12 Card Performance Monitoring Parameters

Figure 15-5 shows the signal types that support near-end and far-end PMs. Figure 15-6 on page 15-16 shows where overhead bytes detected on the ASICs produce performance monitoring parameters for the DS3-12 and DS3N-12 cards.

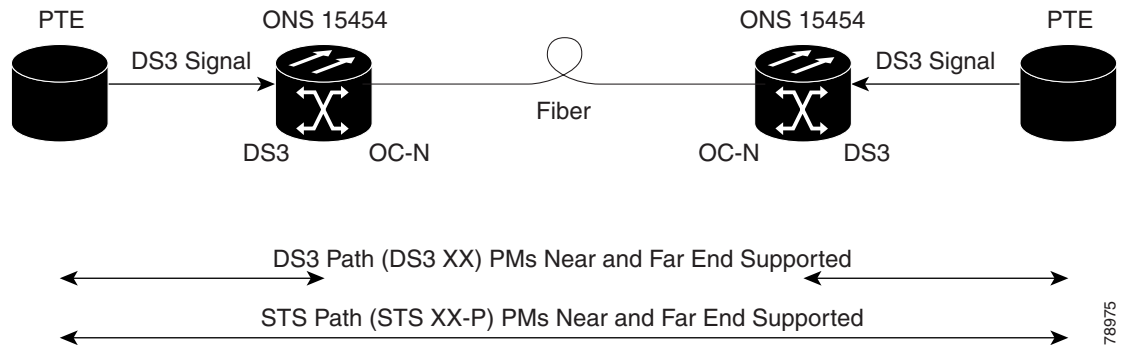
Figure 15-5 Monitored Signal Types for the DS3-12 and DS3N-12 Cards**Note**

The XX in Figure 15-5 represents all PMs listed in Table 15-16 on page 15-16 through Table 15-19 on page 15-18 with the given prefix and/or suffix.

Figure 15-6 PM Read Points on the DS3-12 and DS3N-12 Cards

ONS 15454

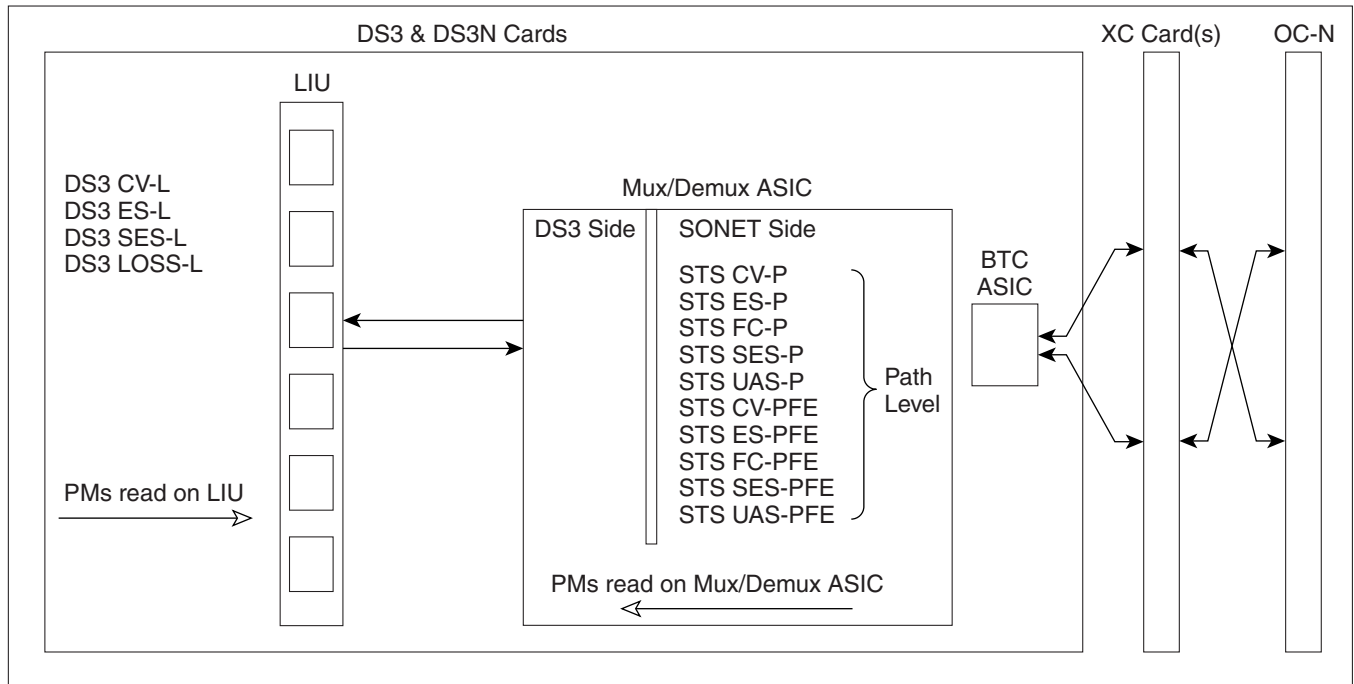

The PM parameters for the DS3-12 and DS3N-12 cards are described in Table 15-16 on page 15-16 through Table 15-19 on page 15-18.

Table 15-16 Near-End DS-3 Line PMs for the DS3-12 and DS3N-12 Cards

Parameter	Definition
DS3 CV-L	Line Code Violation (CV-L) indicates the number of coding violations occurring on the line. This parameter is a count of bipolar violations (BPVs) and excessive zeros (EXZs) occurring over the accumulation period.
DS3 ES-L	Line Errored Seconds (ES-L) is a count of the seconds containing one or more anomalies (BPV + EXZ) and/or defects (loss of signal) on the line.
DS3 SES-L	Line Severely Errored Seconds (SES-L) is a count of the seconds containing more than a particular quantity of anomalies (BPV + EXZ \geq 44) and/or defects on the line.
DS3 LOSS-L	Line Loss of Signal (LOSS-L) is a count of one-second intervals containing one or more LOS defects.

Table 15-17 Near-End DS-3 Path PMs for the DS3-12 and DS3N-12 Cards

Parameter	Definition
DS3 CV-P	Code Violation-Path (CV-P) indicates the number of coding violations occurring on the path. This parameter is a count of bipolar violations (BPVs) and excessive zeros (EXZs) occurring over the accumulation period.
DS3 ES-P	Errored Seconds-Path (ES-P) is a count of one-second intervals containing one or more CRC-6 errors, or one or more CS events, or one or more SEF or AIS defects.
DS3 SES-P	Severely Errored Seconds-Path (SES-P) is a count of seconds where 320 or more CRC-6 errors occur or one or more SEF or AIS defects occur.
DS3 SAS-P	Severely Errored Frame/Alarm Indication Signal-Path (SAS-P) is a count of seconds containing one or more SEFs or one or more AIS defects. Note DS3-12 and DS3N-12 cards support SAS-P only on the receive (Rx) path.
DS3 AISS-P	Alarm Indication Signal Seconds-Path (AISS-P) is a count of seconds containing one or more AIS defects.
DS3 UAS-P	Unavailable Seconds-Path (UAS-P) is a count of one-second intervals during which the DS-3 path is unavailable.

Table 15-18 Near-End SONET Path PMs for the DS3-12 and DS3N-12 Cards

Parameter	Definition
STS CV-P	Near-End STS Path Coding Violations (CV-P) is a count of BIP errors detected at the STS path layer (that is, using the B3 byte). Up to eight BIP errors can be detected per frame; each error increments the current CV-P second register.
STS ES-P	Near-End STS Path Errored Seconds (ES-P) is a count of the seconds when at least one STS path BIP error was detected. An AIS-P defect (or a lower-layer, traffic-related, near-end defect) or an LOP-P defect can also cause an STS ES-P.
STS FC-P	Near-End STS Path Failure Counts (FC-P) is a count of the number of near-end STS path failure events. A failure event begins when an AIS-P failure, an LOP-P failure, a UNEQ-P, or a TIM-P failure is declared. A failure event also begins if the STS PTE that is monitoring the path supports ERDI-P for that path. The failure event ends when these failures are cleared.
STS SES-P	Near-End STS Path Severely Errored Seconds (SES-P) is a count of the seconds when K (2400) or more STS path BIP errors were detected. An AIS-P defect (or a lower-layer, traffic-related, near-end defect) or an LOP-P defect can also cause an STS SES-P.
STS UAS-P	Near-End STS Path Unavailable Seconds (UAS-P) is a count of the seconds when the STS path was unavailable. An STS path becomes unavailable when ten consecutive seconds occur that qualify as SES-Ps, and it continues to be unavailable until ten consecutive seconds occur that do not qualify as SES-Ps.

Table 15-19 Far-End SONET Path PMs for the DS3-12 and DS3N-12 Cards

Parameter	Definition
STS CV-PFE	Far-End STS Path Coding Violations (CV-PFE) is a count of BIP errors detected at the STS path layer (that is, using the B3 byte). Up to eight BIP errors can be detected per frame; each error increments the current CV-PFE second register.
STS ES-PFE	Far-End STS Path Errored Seconds (ES-PFE) is a count of the seconds when at least one STS path BIP error was detected. An AIS-P defect (or a lower-layer, traffic-related, far-end defect) or an LOP-P defect can also cause an STS ES-PFE.
STS FC-PFE	Far-End STS Path Failure Counts (FC-PFE) is a count of the number of far-end STS path failure events. A failure event begins when an AIS-P failure, an LOP-P failure, a UNEQ-P, or a TIM-P failure is declared. A failure event also begins if the STS PTE that is monitoring the path supports ERDI-P for that path. The failure event ends when these failures are cleared.
STS SES-PFE	Far-End STS Path Severely Errored Seconds (SES-PFE) is a count of the seconds when K (2400) or more STS path BIP errors were detected. An AIS-P defect (or a lower-layer, traffic-related, far-end defect) or an LOP-P defect can also cause an STS SES-PFE.
STS UAS-PFE	Far-End STS Path Unavailable Seconds (UAS-PFE) is a count of the seconds when the STS path was unavailable. An STS path becomes unavailable when ten consecutive seconds occur that qualify as SES-PFEs, and it continues to be unavailable until ten consecutive seconds occur that do not qualify as SES-PFEs.

15.5.4 DS3-12E and DS3N-12E Card Performance Monitoring Parameters

Figure 15-7 shows the signal types that support near-end and far-end PMs. Figure 15-8 on page 15-19 shows where overhead bytes detected on the ASICs produce performance monitoring parameters for the DS3-12E and DS3N-12E cards.

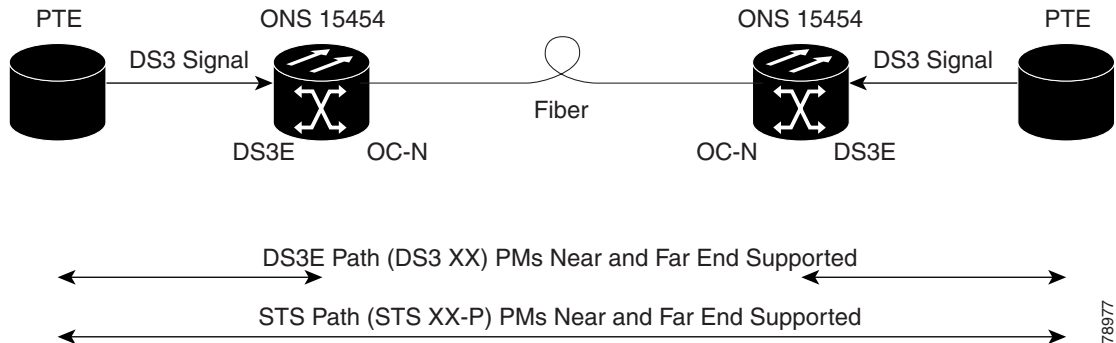
Figure 15-7 Monitored Signal Types for the DS3-12E and DS3N-12E Cards

Note

The XX in Figure 15-7 on page 15-18 represents all PMs listed in Table 15-20 on page 15-19 through Table 15-25 on page 15-22 with the given prefix and/or suffix.

Figure 15-8 PM Read Points on the DS3-12E and DS3N-12E Cards

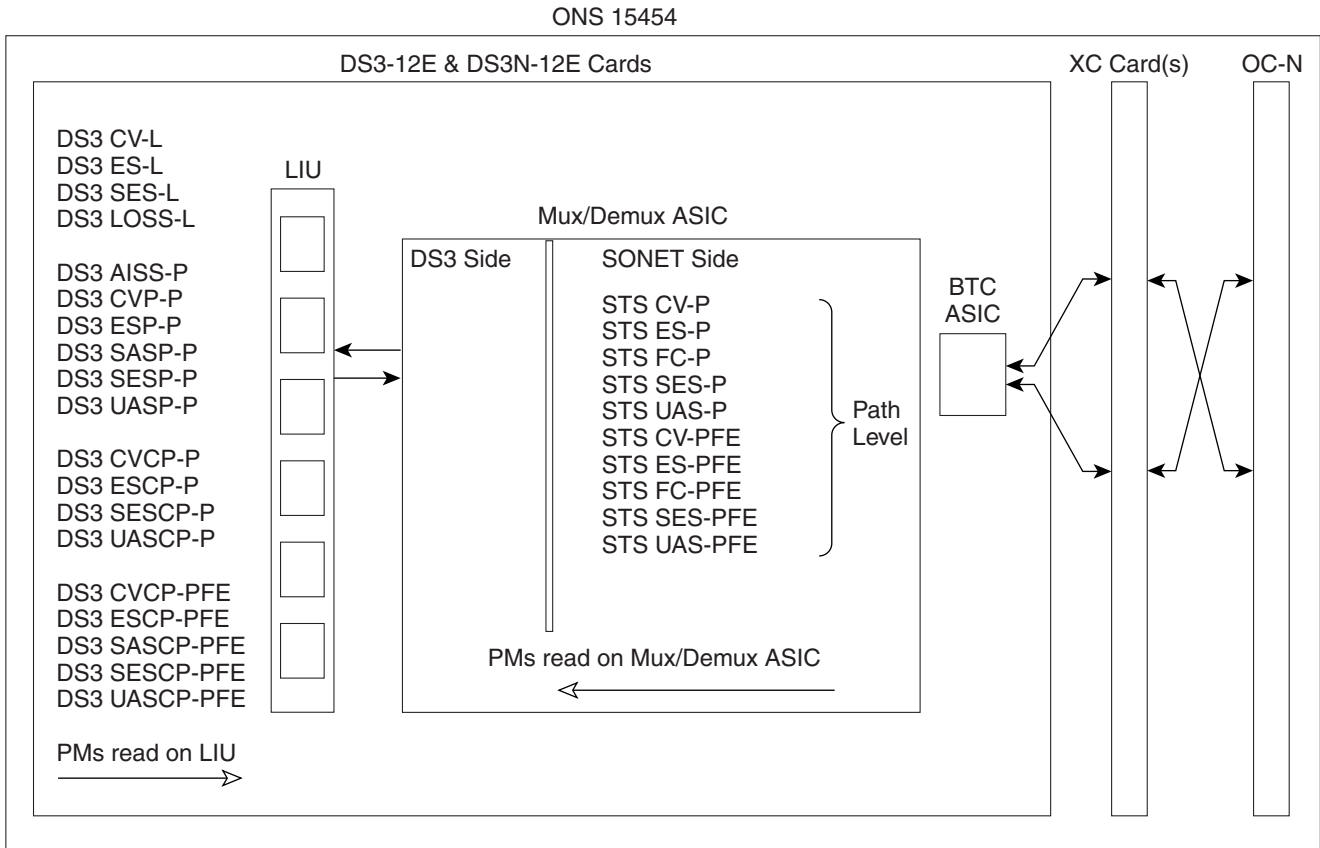

The PM parameters for the DS3-12E and DS3N-12E cards are described in Table 15-20 through Table 15-25 on page 15-22.

Table 15-20 Near-End DS-3 Line PMs for the DS3-12E and DS3N-12E Cards

Parameter	Definition
DS3 CV-L	Line Code Violation (CV-L) indicates the number of coding violations occurring on the line. This parameter is a count of bipolar violations (BPVs) and excessive zeros (EXZs) occurring over the accumulation period.
DS3 ES-L	Line Errored Seconds (ES-L) is a count of the seconds containing one or more anomalies (BPV + EXZ) and/or defects (that is, loss of signal) on the line.

Table 15-20 Near-End DS-3 Line PMs for the DS3-12E and DS3N-12E Cards (continued)

Parameter	Definition
DS3 SES-L	Line Severely Errored Seconds (SES-L) is a count of the seconds containing more than a particular quantity of anomalies (BPV + EXZ \geq 44) and/or defects on the line.
DS3 LOSS-L	Line Loss of Signal (LOSS-L) is a count of one-second intervals containing one or more LOS defects.

Table 15-21 Near-End P-Bit Path PMs for the DS3-12E and DS3N-12E Cards

Parameter	Definition
DS3 AISS-P	AIS Seconds Path (AISS-P) is a count of one-second intervals containing one or more AIS defects.
DS3 CVP-P	Code Violation Path (CVP-P) is a code violation parameter for M23 applications. CVP-P is a count of P-bit parity errors occurring in the accumulation period.
DS3 ESP-P	Errored Second Path (ESP-P) is a count of seconds containing one or more P-bit parity errors, one or more SEF defects, or one or more AIS defects.
DS3 SASP-P	SEF/AIS Seconds Path (SASP-P) is a count of one-second intervals containing one or more SEFs or one or more AIS defects on the path.
DS3 SESP-P	Severely Errored Seconds Path (DS-3 SESP-P) is a count of seconds containing more than 44 P-bit parity violations, one or more SEF defects, or one or more AIS defects.
DS3 UASP-P	Unavailable Second Path (DS-3 UASP-P) is a count of one-second intervals when the DS-3 path is unavailable. A DS-3 path becomes unavailable when ten consecutive SESP-Ps occur. The ten SESP-Ps are included in unavailable time. Once unavailable, the DS-3 path becomes available when ten consecutive seconds with no SESP-Ps occur. The ten seconds with no SESP-Ps are excluded from unavailable time.

Table 15-22 Near-End CP-Bit Path PMs for the DS3-12E and DS3N-12E Cards

Parameter	Definition
DS3 CVCP-P	Code Violation CP-bit Path (CVCP-P) is a count of CP-bit parity errors occurring in the accumulation period.
DS3 ESCP-P	Errored Second CP-bit Path (ESCP-P) is a count of seconds containing one or more CP-bit parity errors, one or more SEF defects, or one or more AIS defects. ESCP-P is defined for the C-bit parity application.
DS3 SASCP-P	SEF/AIS Seconds CP-bit Path (SASCP-P) is a count of one-second intervals containing one or more SEFs or one or more AIS defects on the path.

Table 15-22 Near-End CP-Bit Path PMs for the DS3-12E and DS3N-12E Cards (continued)

Parameter	Definition
DS3 SESCO-P	Severely Errored Seconds CP-bit Path (SESCP-P) is a count of seconds containing more than 44 CP-bit parity errors, one or more SEF defects, or one or more AIS defects.
DS3 UASCP-P	Unavailable Seconds CP-bit Path (UASCP-P) is a count of one-second intervals when the DS-3 path is unavailable. A DS-3 path becomes unavailable when ten consecutive SESCO-Ps occur. The ten SESCO-Ps are included in unavailable time. Once unavailable, the DS-3 path becomes available when ten consecutive seconds with no SESCO-Ps occur. The ten seconds with no SESCO-Ps are excluded from unavailable time.

Table 15-23 Near-End SONET Path PMs for the DS3-12E and DS3N-12E Cards

Parameter	Definition
STS CV-P	Near-End STS Path Coding Violations (CV-P) is a count of BIP errors detected at the STS path layer (that is, using the B3 byte). Up to eight BIP errors can be detected per frame; each error increments the current CV-P second register.
STS ES-P	Near-End STS Path Errored Seconds (ES-P) is a count of the seconds when at least one STS path BIP error was detected. An AIS-P defect (or a lower-layer, traffic-related, near-end defect) or an LOP-P defect can also cause an STS ES-P.
STS FC-P	Near-End STS Path Failure Counts (FC-P) is a count of the number of near-end STS path failure events. A failure event begins when an AIS-P failure, an LOP-P failure, a UNEQ-P, or a TIM-P failure is declared. A failure event also begins if the STS PTE that is monitoring the path supports ERDI-P for that path. The failure event ends when these failures are cleared.
STS SES-P	Near-End STS Path Severely Errored Seconds (SES-P) is a count of the seconds when K (2400) or more STS path BIP errors were detected. An AIS-P defect (or a lower-layer, traffic-related, near-end defect) or an LOP-P defect can also cause an STS SES-P.
STS UAS-P	Near-End STS Path Unavailable Seconds (UAS-P) is a count of the seconds when the STS path was unavailable. An STS path becomes unavailable when ten consecutive seconds occur that qualify as SES-Ps, and continues to be unavailable until ten consecutive seconds occur that do not qualify as SES-Ps.

Table 15-24 Far-End CP-bit Path PMs for the DS3-12E and DS3N-12E Cards

Parameter	Definition
DS3 CVCP-PFE	Code Violation CP-bit Path (CVCP-PFE) is a parameter that is counted when the three far-end block error (FEBE) bits in a M-frame are not all collectively set to 1.
DS3 ESCP-PFE	Errored Second CP-bit Path (ESCP-PFE) is a count of one-second intervals containing one or more M-frames with the three FEBE bits not all collectively set to 1 or one or more far-end SEF/AIS defects.
DS3 SASCP-PFE	SEF/AIS Second CP-bit Path (SASCP-PFE) is a count of one-second intervals containing one or more far-end SEF/AIS defects.
DS3 SESCO-PFE	Severely Errored Second CP-bit Path (SESCO-PFE) is a count of one-second intervals containing one or more 44 M-frames with the three FEBE bits not all collectively set to 1 or one or more far-end SEF/AIS defects.
DS3 UASCP-PFE	Unavailable Second CP-bit Path (UASCP-PFE) is a count of one-second intervals when the DS-3 path becomes unavailable. A DS-3 path becomes unavailable when ten consecutive far-end CP-bit SESs occur. The ten CP-bit SESs are included in unavailable time. Once unavailable, the DS-3 path becomes available when ten consecutive seconds occur with no CP-bit SESs. The ten seconds with no CP-bit SESs are excluded from unavailable time.

Table 15-25 Far-End SONET Path PMs for the DS3-12E and DS3N-12E Cards

Parameter	Definition
STS CV-PFE	Far-End STS Path Coding Violations (CV-PFE) is a count of BIP errors detected at the STS path layer (that is, using the B3 byte). Up to eight BIP errors can be detected per frame; each error increments the current CV-PFE second register.
STS ES-PFE	Far-End STS Path Errored Seconds (ES-PFE) is a count of the seconds when at least one STS path BIP error was detected. An AIS-P defect (or a lower-layer, traffic-related, far-end defect) or an LOP-P defect can also cause an STS ES-PFE.
STS FC-PFE	Far-End STS Path Failure Counts (FC-PFE) is a count of the number of near-end STS path failure events. A failure event begins when an AIS-P failure, an LOP-P failure, a UNEQ-P, or a TIM-P failure is declared. A failure event also begins if the STS PTE that is monitoring the path supports ERDI-P for that path. The failure event ends when these failures are cleared.

Table 15-25 Far-End SONET Path PMs for the DS3-12E and DS3N-12E Cards (continued)

Parameter	Definition
STS SES-PFE	Far-End STS Path Severely Errored Seconds (SES-PFE) is a count of the seconds when K (2400) or more STS path BIP errors were detected. An AIS-P defect (or a lower-layer, traffic-related, far-end defect) or an LOP-P defect can also cause an STS SES-PFE.
STS UAS-PFE	Far-End STS Path Unavailable Seconds (UAS-PFE) is a count of the seconds when the STS path was unavailable. An STS path becomes unavailable when ten consecutive seconds occur that qualify as SES-PFEs, and continues to be unavailable until ten consecutive seconds occur that do not qualify as SES-PFEs.

15.5.5 DS3XM-6 Card Performance Monitoring Parameters

Figure 15-9 shows the signal types that support near-end and far-end PMs. Figure 15-10 on page 15-24 shows where the overhead bytes detected on the ASICs produce performance monitoring parameters for the DS3XM-6 card.

Figure 15-9 Monitored Signal Types for the DS3XM-6 Card

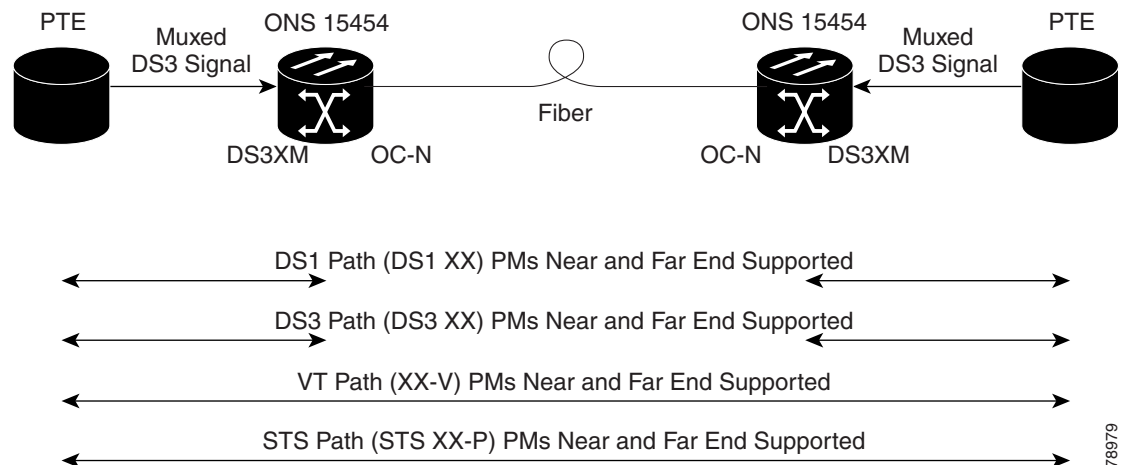
Note

The XX in Figure 15-9 represents all PMs listed in Table 15-26 on page 15-24 through Table 15-34 on page 15-28 with the given prefix and/or suffix.

Figure 15-10 PM Read Points on the DS3XM-6 Card

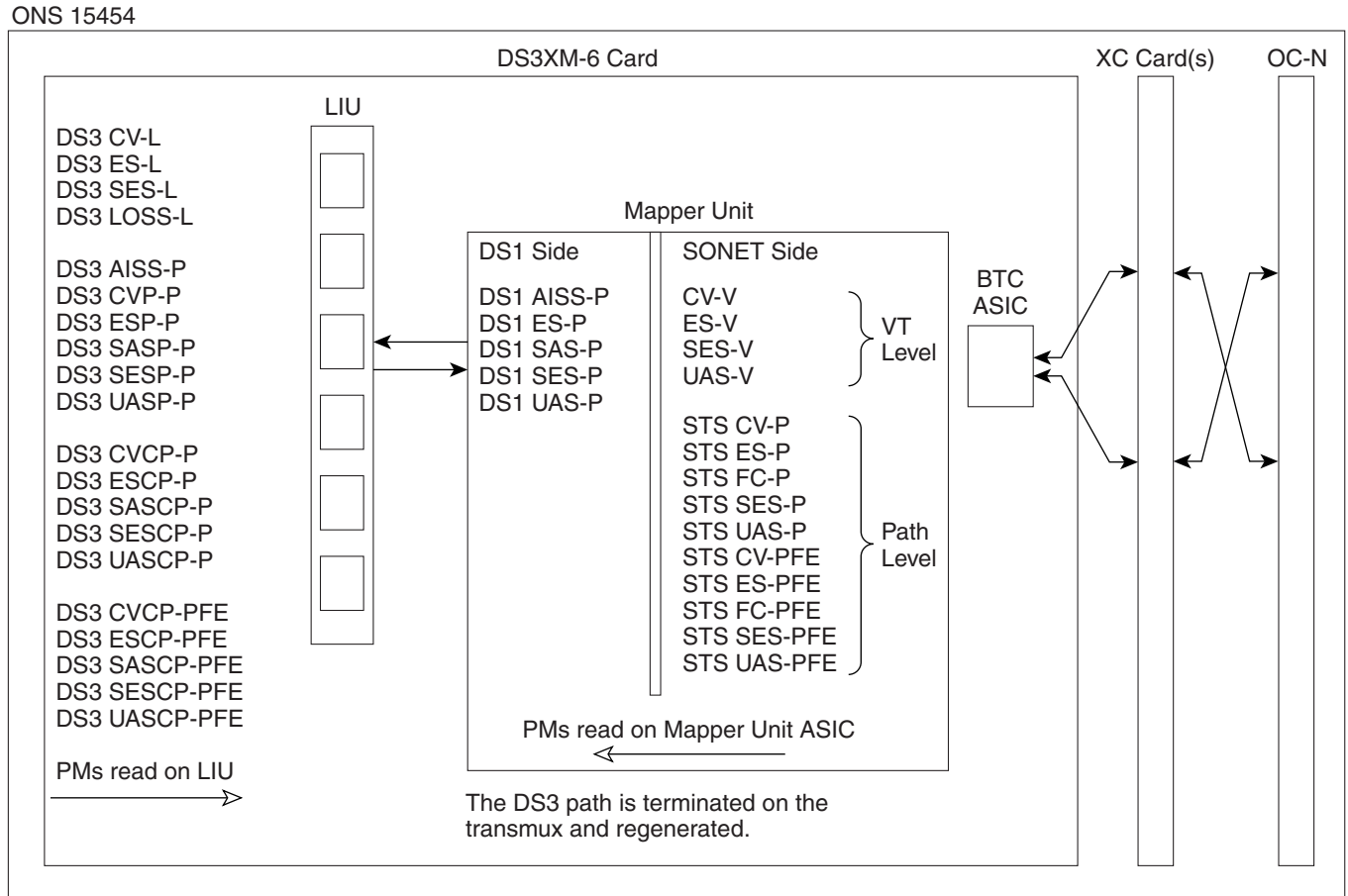

The PM parameters for the DS3XM-6 cards are described in Table 15-26 through Table 15-34 on page 15-28.

Table 15-26 Near-End DS-3 Line PMs for the DS3XM-6 Card

Parameter	Definition
DS3 CV-L	Line Code Violation (CV-L) indicates the number of coding violations occurring on the line. This parameter is a count of bipolar violations (BPVs) and excessive zeros (EXZs) occurring over the accumulation period.
DS3 ES-L	Line Errored Seconds (ES-L) is a count of the seconds containing one or more anomalies (BPV + EXZ) and/or defects (that is, LOS) on the line.
DS3 SES-L	Line Severely Errored Seconds (SES-L) is a count of the seconds containing more than a particular quantity of anomalies (BPV + EXZ \geq 44) and/or defects on the line.
DS3 LOSS-L	Line Loss of Signal (LOSS-L) is a count of one-second intervals containing one or more LOS defects.

Table 15-27 Near-End P-Bit Path PMs for the DS3XM-6 Card

Parameter	Definition
DS3 AISS-P	AIS Seconds Path (AISS-P) is a count of one-second intervals containing one or more AIS defects.
DS3 CVP-P	Code Violation Path (CVP-P) is a code violation parameter for M23 applications. CVP-P is a count of P-bit parity errors occurring in the accumulation period.
DS3 ESP-P	Errored Second Path (ESP-P) is a count of seconds containing one or more P-bit parity errors, one or more SEF defects, or one or more AIS defects.
DS3 SASP-P	SEF/AIS Seconds Path (SASP-P) is a count of one-second intervals containing one or more SEFs or one or more AIS defects on the path.
DS3 SESP-P	Severely Errored Seconds Path (SESP-P) is a count of seconds containing more than 44 P-bit parity violations, one or more SEF defects, or one or more AIS defects.
DS3 UASP-P	Unavailable Second Path (UASP-P) is a count of one-second intervals when the DS-3 path is unavailable. A DS-3 path becomes unavailable when ten consecutive SESP-Ps occur. The ten SESP-Ps are included in unavailable time. Once unavailable, the DS-3 path becomes available when ten consecutive seconds with no SESP-Ps occur. The ten seconds with no SESP-Ps are excluded from unavailable time.

Table 15-28 Near-End CP-Bit Path PMs for the DS3XM-6 Card

Parameter	Definition
DS3 CVCP-P	Code Violation Path (CVCP-P) is a count of CP-bit parity errors occurring in the accumulation period.
DS3 ESCP-P	Errored Second Path (ESCP-P) is a count of seconds containing one or more CP-bit parity errors, one or more SEF defects, or one or more AIS defects.
DS3 SASCP-P	SEF/AIS Second (SASCP-PFE) is a count of one-second intervals containing one or more near-end SEF/AIS defects.
DS3 SESCP-P	Severely Errored Seconds Path (SESCP-P) is a count of seconds containing more than 44 CP-bit parity errors, one or more SEF defects, or one or more AIS defects.
DS3 UASCP-P	Unavailable Seconds Path (DS-3 UASCP-P) is a count of one-second intervals when the DS-3 path is unavailable. A DS-3 path becomes unavailable when ten consecutive SESCP-Ps occur. The ten SESCP-Ps are included in unavailable time. Once unavailable, the DS-3 path becomes available when ten consecutive seconds with no SESCP-Ps occur. The ten seconds with no SESCP-Ps are excluded from unavailable time.

Table 15-29 Near-End DS-1 Path PMs for the DS3XM-6 Card

Parameter	Definition
DS1 AISS-P	Alarm Indication Signal Path (AIS-P) means an AIS occurred on the path. This parameter is a count of seconds containing one or more AIS defects.
DS1 ES-P	Errored Seconds Path (ES-P) is a count of the seconds containing one or more anomalies and/or defects for paths. For DS1-ESF paths, this parameter is a count of one-second intervals containing one or more CRC-6 errors, or one or more CS events, or one or more SEF or AIS defects. For DS1-SF paths, the ES-P parameter is a count of one-second intervals containing one or more FE events, or one or more CS events, or one or more SEF or AIS defects.
DS1 SAS-P	Severely Errored Seconds Path Frame/Alarm Indication Signal (SAS-P) is a count of one-second intervals containing one or more SEFs or one or more AIS defects. Note The DS3XM-6 card supports SAS-P only on the receive (Rx) path.
DS1 SES-P	Severely Errored Seconds Path (SES-P) is a count of the seconds containing more than a particular quantity of anomalies and/or defects for paths. For the DS1-ESF paths, this parameter is a count of seconds when 320 or more CRC-6 errors or one or more SEF or AIS defects occurs. For DS1-SF paths, an SES is a second containing either the occurrence of eight FEs, four FEs, or one or more SEF or AIS defects.
DS1 UAS-P	Unavailable Seconds Path (UAS-P) is a count of one-second intervals when the DS-1 path is unavailable. The DS-1 path is unavailable when ten consecutive SESs occur. The ten SESs are included in unavailable time. Once unavailable, the DS-1 path becomes available when ten consecutive seconds occur with no SESs. The ten seconds with no SESs are excluded from unavailable time.

Table 15-30 Near-End VT PMs for the DS3XM-6 Card

Parameter	Definition
CV-V	Code Violation VT Layer (CV-V) is a count of the BIP errors detected at the VT path layer. Up to two BIP errors can be detected per VT superframe; each error increments the current CV-V second register.
ES-V	Errored Seconds VT Layer (ES-V) is a count of the seconds when at least one VT Path BIP error was detected. An AIS-V defect (or a lower-layer, traffic-related, near-end defect) or an LOP-V defect can also cause ES-V.
SES-V	Severely Errored Seconds VT Layer (SES-V) is a count of seconds when K (600) or more VT Path BIP errors were detected. An AIS-V defect (or a lower-layer, traffic-related, near-end defect) or an LOP-V defect can also cause SES-V.
UAS-V	Unavailable Seconds VT Layer (UAS-V) is a count of the seconds when the VT path was unavailable. A VT path becomes unavailable when ten consecutive seconds occur that qualify as SES-Vs and continues to be unavailable until ten consecutive seconds occur that do not qualify as SES-Vs.

Table 15-31 Near-End SONET Path PMs for the DS3XM-6 Card

Parameter	Definition
STS CV-P	Near-End STS Path Coding Violations (CV-P) is a count of BIP errors detected at the STS path layer (that is, using the B3 byte). Up to eight BIP errors can be detected per frame; each error increments the current CV-P second register.
STS ES-P	Near-End STS Path Errored Seconds (ES-P) is a count of the seconds when at least one STS path BIP error was detected. An AIS-P defect (or a lower-layer, traffic-related, near-end defect) or an LOP-P defect can also cause an STS ES-P.
STS FC-P	Near-End STS Path Failure Counts (FC-P) is a count of the number of near-end STS path failure events. A failure event begins when an AIS-P failure, an LOP-P failure, a UNEQ-P failure, or a TIM-P failure is declared. A failure event also begins if the STS PTE that is monitoring the path supports ERDI-P for that path. The failure event ends when these failures are cleared.
STS SES-P	Near-End STS Path Severely Errored Seconds (SES-P) is a count of the seconds when K (2400) or more STS path BIP errors were detected. An AIS-P defect (or a lower-layer, traffic-related, near-end defect) or an LOP-P defect can also cause an STS SES-P.
STS UAS-P	Near-End STS Path Unavailable Seconds (UAS-P) is a count of the seconds when the STS path was unavailable. An STS path becomes unavailable when ten consecutive seconds occur that qualify as SES-Ps, and it continues to be unavailable until ten consecutive seconds occur that do not qualify as SES-Ps.

Table 15-32 Far-End CP-bit Path PMs for the DS3XM-6 Card

Parameter	Definition
DS3 CVCP-PFE	Code Violation (CVCP-PFE) is a parameter that is counted when the three FEBE bits in a M-frame are not all collectively set to 1.
DS3 ESCP-PFE	Errored Second (ESCP-PFE) is a count of one-second intervals containing one or more M-frames with the three FEBE bits not all collectively set to 1 or one or more far-end SEF/AIS defects.
DS3 SASCP-PFE	SEF/AIS Second (SASCP-PFE) is a count of one-second intervals containing one or more far-end SEF/AIS defects.
DS3 SESCO-PFE	Severely Errored Second (SESCO-PFE) is a count of one-second intervals containing one or more 44 M-frames with the three FEBE bits not all collectively set to 1 or one or more far-end SEF/AIS defects.
DS3 UASCP-PFE	Unavailable Second (UASCP-PFE) is a count of one-second intervals when the DS-3 path becomes unavailable. A DS-3 path becomes unavailable when ten consecutive far-end CP-bit SESs occur. The ten CP-bit SESs are included in unavailable time. Once unavailable, the DS-3 path becomes available when ten consecutive seconds with no CP-bit SESs occur. The ten seconds with no CP-bit SESs are excluded from unavailable time.

Table 15-33 Far-End VT PMs for the DS3XM-6 Card

Parameter	Definition
CV-VFE	Code Violation VT Layer (CV-VFE) is a count of the BIP errors detected at the VT path layer. Up to two BIP errors can be detected per VT superframe; each error increments the current CV-V second register.
ES-VFE	Errored Seconds VT Layer (ES-VFE) is a count of the seconds when at least one VT Path BIP error was detected. An AIS-V defect (or a lower-layer, traffic-related, near-end defect) or an LOP-V defect can also cause an ES-V.
SES-VFE	Severely Errored Seconds VT Layer (SES-VFE) is a count of seconds when K (600) or more VT Path BIP errors were detected. An AIS-V defect (or a lower-layer, traffic-related, near-end defect) or an LOP-V defect can also cause an SES-V.
UAS-VFE	Unavailable Second VT Layer (UAS-VFE) is a count of the seconds when the VT path was unavailable. A VT path becomes unavailable when ten consecutive seconds occur that qualify as SES-Vs and continues to be unavailable until ten consecutive seconds occur that do not qualify as SES-Vs.

Table 15-34 Far-End SONET Path PMs for the DS3XM-6 Card

Parameter	Definition
STS CV-PFE	Far-End STS Path Coding Violations (CV-PFE) is a count of BIP errors detected at the STS path layer (that is, using the B3 byte). Up to eight BIP errors can be detected per frame; each error increments the current CV-PFE second register.
STS ES-PFE	Far-End STS Path Errored Seconds (ES-PFE) is a count of the seconds when at least one STS path BIP error was detected. An AIS-P defect (or a lower-layer, traffic-related, far-end defect) or an LOP-P defect can also cause an STS ES-PFE.
STS FC-PFE	Far-End STS Path Failure Counts (FC-PFE) is a count of the number of near-end STS path failure events. A failure event begins when an AIS-P failure, an LOP-P failure, a UNEQ-P failure, or a TIM-P failure is declared. A failure event also begins if the STS PTE that is monitoring the path supports ERDI-P for that path. The failure event ends when these failures are cleared.
STS SES-PFE	Far-End STS Path Severely Errored Seconds (SES-PFE) is a count of the seconds when K (2400) or more STS path BIP errors were detected. An AIS-P defect (or a lower-layer, traffic-related, far-end defect) or an LOP-P defect can also cause an STS SES-PFE.
STS UAS-PFE	Far-End STS Path Unavailable Seconds (UAS-PFE) is a count of the seconds when the STS path was unavailable. An STS path becomes unavailable when ten consecutive seconds occur that qualify as SES-PFEs, and it continues to be unavailable until ten consecutive seconds occur that do not qualify as SES-PFEs.

15.6 Performance Monitoring for Ethernet Cards

The following sections define performance monitoring parameters and definitions for the E-Series, G-Series, and ML-Series Ethernet cards.

15.6.1 E-Series Ethernet Card Performance Monitoring Parameters

CTC provides Ethernet performance information, including line-level parameters, port bandwidth consumption, and historical Ethernet statistics. The E-Series Ethernet performance information is divided into the Statistics, Utilization, and History tabbed windows within the card view Performance tab window.

15.6.1.1 E-Series Ethernet Statistics Window

The Ethernet statistics window lists Ethernet parameters at the line level. The Statistics window provides buttons to change the statistical values shown. The Baseline button resets the displayed statistics values to zero. The Refresh button manually refreshes statistics. Auto-Refresh sets a time interval at which automatic refresh occurs.

Table 15-35 defines the E-Series Ethernet card Statistics parameters.

Table 15-35 E-Series Ethernet Statistics Parameters

Parameter	Meaning
Link Status	Indicates whether link integrity is present; up means present, and down means not present.
Rx Packets	Number of packets received since the last counter reset.
Rx Bytes	Number of bytes received since the last counter reset.
Tx Packets	Number of packets transmitted since the last counter reset.
Tx Bytes	Number of bytes transmitted since the last counter reset.
Rx Total Errors	Total number of receive errors.
Rx FCS	Number of packets with a Frame Check Sequence (FCS) error. FCS errors indicate frame corruption during transmission.
Rx Alignment	Number of packets with alignment errors; alignment errors are received incomplete frames.
Rx Runts	Number of packets received that are less than 64 bytes in length.
Rx Giants	Number of packets received that are greater than 1518 bytes in length for untagged interfaces and 1522 bytes for tagged interfaces.
Tx Collisions	Number of transmit packets that are collisions; the port and the attached device transmitting at the same time caused collisions.
Tx Late Collisions	Number of frames that were not transmitted since they encountered a collision outside of the normal collision window (late collision events should occur only rarely).

Table 15-35 E-Series Ethernet Statistics Parameters (continued)

Parameter	Meaning
Tx Excessive Collisions	Number of consecutive collisions.
Tx Deferred	Number of packets deferred.

15.6.1.2 E-Series Ethernet Utilization Window

The Utilization window shows the percentage of transmit (Tx) and receive (Rx) line bandwidth used by the Ethernet ports during consecutive time segments. The Mode field displays the real-time mode status, such as 100 Full, which is the mode setting configured on the E-Series port. However, if the E-Series port is set to autonegotiate the mode (Auto), this field shows the result of the link negotiation between the E-Series and the peer Ethernet device attached directly to the E-Series port.

The Utilization window provides an Interval menu that enables you to set time intervals of 1 minute, 15 minutes, 1 hour, and 1 day. Line utilization is calculated with the following formulas:

$$Rx = (\text{inOctets} + \text{inPkts} * 20) * 8 / 100\% \text{ interval} * \text{maxBaseRate}.$$

$$Tx = (\text{outOctets} + \text{outPkts} * 20) * 8 / 100\% \text{ interval} * \text{maxBaseRate}.$$

The interval is defined in seconds. The maxBaseRate is defined by raw bits per second in one direction for the Ethernet port (that is, 1 Gbps). The maxBaseRate for E-series Ethernet cards is shown in Table 15-36.

Table 15-36 maxBaseRate for STS Circuits

STS	maxBaseRate
STS-1	51840000
STS-3c	155000000
STS-6c	311000000
STS-12c	622000000

**Note**

Line utilization numbers express the average of ingress and egress traffic as a percentage of capacity.

**Note**

The E-Series Ethernet card is a Layer 2 device or switch and supports Trunk Utilization statistics. The Trunk Utilization statistics are similar to the Line Utilization statistics, but shows the percentage of circuit bandwidth used rather than the percentage of line bandwidth used. The Trunk Utilization statistics are accessed via the card view Maintenance tab.

15.6.1.3 E-Series Ethernet History Window

The Ethernet History window lists past Ethernet statistics for the previous time intervals. Depending on the selected time interval, the History window displays the statistics for each port for the number of previous time intervals as shown in Table 15-37 on page 15-31. The listed parameters are defined in Table 15-35 on page 15-29.

Table 15-37 Ethernet History Statistics per Time Interval

Time Interval	Number of Intervals Displayed
1 minute	60 previous time intervals
15 minutes	32 previous time intervals
1 hour	24 previous time intervals
1 day (24 hours)	7 previous time intervals

15.6.2 G-Series Ethernet Card Performance Monitoring Parameters

CTC provides Ethernet performance information, including line-level parameters, port bandwidth consumption, and historical Ethernet statistics. The G-Series Ethernet performance information is divided into the Statistics, Utilization, and History tabbed windows within the card view Performance tab window.

15.6.2.1 G-Series Ethernet Statistics Window

The Ethernet statistics window lists Ethernet parameters at the line level. The Statistics window provides buttons to change the statistical values shown. The Baseline button resets the displayed statistics values to zero. The Refresh button manually refreshes statistics. Auto-Refresh sets a time interval at which automatic refresh occurs. The G-Series Statistics window also has a Clear button. The Clear button sets the values on the card to zero, but does not reset the G-Series card.

In R 4.1.x, G-Series Ethernet performance-monitoring counts behave somewhat differently from the E-Series statistical count. During each automatic cycle, whether auto-refreshed or manually refreshed (using the Refresh button), statistics are added cumulatively and are not immediately adjusted to equal total received packets until testing ends. To see the final PM count totals, allow a few moments for the PM window statistics to finish testing and update fully. PM counts are also listed in the G-Series Ethernet card Performance > History window.

Table 15-38 defines the G-Series Ethernet card Statistics parameters.

Table 15-38 G-Series Ethernet Statistics Parameters

Parameter	Meaning
Time Last Cleared	A time stamp indicating the last time statistics were reset.
Link Status	Indicates whether the Ethernet link is receiving a valid Ethernet signal (carrier) from the attached Ethernet device; up means present, and down means not present.
Rx Packets	Number of packets received since the last counter reset.
Rx Bytes	Number of bytes received since the last counter reset.
Tx Packets	Number of packets transmitted since the last counter reset.
Tx Bytes	Number of bytes transmitted since the last counter reset.
Rx Total Errors	Total number of receive errors.
Rx FCS	Number of packets with a Frame Check Sequence (FCS) error. FCS errors indicate frame corruption during transmission.

Table 15-38 G-Series Ethernet Statistics Parameters (continued)

Parameter	Meaning
Rx Alignment	Number of packets with received incomplete frames.
Rx Runts	The total number of frames received that are less than 64 bytes in length and have a CRC error.
Rx Jabbers	The total number of frames received that exceed the 1548-byte maximum and contain CRC errors.
Rx Pause Frames	Number of received Ethernet 802.3z pause frames.
Tx Pause Frames	Number of transmitted 802.3z pause frames.
Rx Pkts Dropped Internal Congestion	Number of received packets dropped due to overflow in G-Series frame buffer.
Tx Pkts Dropped Internal Congestion	Number of transmit queue drops due to drops in the G-Series frame buffer.
HDLC Errors	High-level data link control (HDLC) errors received from SONET/SDH (see Note).

**Note**

Do not use the HDLC errors counter to count the number of frames dropped because of HDLC errors, because each frame can fragment into several smaller frames during HDLC error conditions and spurious HDLC frames can also be generated. If HDLC error counters are incrementing when no SONET path problems should be present, it might indicate a problem with the quality of the SONET path. For example, a SONET protection switch generates a set of HDLC errors. But the actual values of these counters are less significant than the fact that they are changing.

15.6.2.2 G-Series Ethernet Utilization Window

The Utilization window shows the percentage of transmit (Tx) and receive (Rx) line bandwidth used by the Ethernet ports during consecutive time segments. The Mode field displays the real-time mode status, such as 100 Full, which is the mode setting configured on the G-Series port. However, if the G-Series port is set to autonegotiate the mode (Auto), this field shows the result of the link negotiation between the G-Series and the peer Ethernet device attached directly to the G-Series port.

The Utilization window provides an Interval menu that enables you to set time intervals of 1 minute, 15 minutes, 1 hour, and 1 day. Line utilization is calculated with the following formulas:

$$\text{Rx} = (\text{inOctets} + \text{inPkts} * 20) * 8 / 100\% \text{ interval} * \text{maxBaseRate}.$$

$$\text{Tx} = (\text{outOctets} + \text{outPkts} * 20) * 8 / 100\% \text{ interval} * \text{maxBaseRate}.$$

The interval is defined in seconds. The maxBaseRate is defined by raw bits per second in one direction for the Ethernet port (that is, 1 Gbps). The maxBaseRate for G-series Ethernet cards is shown in Table 15-39.

Table 15-39 maxBaseRate for STS Circuits

STS	maxBaseRate
STS-1	51840000
STS-3c	155000000

Table 15-39 maxBaseRate for STS Circuits (continued)

STS	maxBaseRate
STS-6c	311000000
STS-12c	622000000

**Note**

Line utilization numbers express the average of ingress and egress traffic as a percentage of capacity.

**Note**

Unlike the E-Series, the G Series card does not have a display of Trunk Utilization statistics, because the G-Series card is not a Layer 2 device or switch.

15.6.2.3 G-Series Ethernet History Window

The Ethernet History window lists past Ethernet statistics for the previous time intervals. Depending on the selected time interval, the History window displays the statistics for each port for the number of previous time intervals as shown in Table 15-40. The listed parameters are defined in Table 15-38 on page 15-31.

Table 15-40 Ethernet History Statistics per Time Interval

Time Interval	Number of Intervals Displayed
1 minute	60 previous time intervals
15 minutes	32 previous time intervals
1 hour	24 previous time intervals
1 day (24 hours)	7 previous time intervals

15.6.3 ML-Series Ethernet Card Performance Monitoring Parameters

CTC provides Ethernet performance information for line-level parameters and historical Ethernet statistics. The ML-Series Ethernet performance information is divided into the Ether Ports and POS Ports tabbed windows within the card view Performance tab window.

Table 15-41 defines the ML-Series Ethernet card Ether Ports PM parameters.

Table 15-41 ML-Series Ether Ports PM Parameters

Parameter	Meaning
Rx Bytes	Number of bytes received since the last counter reset.
Rx Packets	Number of packets received since the last counter reset.
Rx Unicast Packets	Number of unicast packets received since the last counter reset.
Rx Multicast Packets	Number of multicast packets received since the last counter reset.
Rx Broadcast Packets	Number of broadcast packets received since the last counter reset.

Table 15-41 ML-Series Ether Ports PM Parameters (continued)

Parameter	Meaning
Rx Giants	Number of packets received that are greater than 1530 bytes in length.
Rx Total Errors	Total number of receive errors.
Rx FCS Errors	Number of packets with a Frame Check Sequence (FCS) error.
Rx Runts	Total number of frames received that are less than 64 bytes in length and have a cyclic redundancy check (CRC) error.
Rx Jabbers	Total number of frames received that exceed the maximum 1548 bytes and contain CRC errors.
Rx Alignment	Number of received packets with alignment errors.
Tx Packets	Number of packets transmitted since the last counter reset.
Tx Bytes	Number of bytes transmitted since the last counter reset.
Tx Unicast Packets	Number of unicast packets transmitted.
Tx Multicast Packets	Number of multicast packets transmitted.
Tx Broadcast Packets	Number or broadcast packets transmitted.
Tx Giants	Number of packets transmitted that are greater than 1548 bytes in length.
Tx Collisions	Number of transmitted packets that collided.
Port Drop Counts	Number of received frames dropped at the port level.
Rx Pause Frames	Number of received pause frames.
Rx Threshold Oversizes	Number of received packets larger than the ML-Series remote monitoring (RMON) threshold.
Rx GMAC Drop Counts	Number of received frames dropped by MAC module.
Tx Pause Frames	Number of transmitted pause frames.

Table 15-42 defines the ML-Series Ethernet card POS Ports parameters.

Table 15-42 ML-Series POS Ports Parameters

Parameter	Meaning
Rx Pre Hdlc Bytes	Number of bytes received prior to the bytes HDLC encapsulation by the policy engine.
Rx Post Hdlc Bytes	Number of bytes received after the bytes HDLC encapsulation by the policy engine.
Rx Packets	Number of packets received since the last counter reset.
Rx Normal Packets	Number of packets between the minimum and maximum packet size received.
Rx Shorts	Number of packets below the minimum packet size received.
Rx Runts	Total number of frames received that are less than 64 bytes in length and have a CRC error.

Table 15-42 ML-Series POS Ports Parameters (continued)

Parameter	Meaning
Rx Longs	Counter for the number of received frames that exceed the maximum valid packet length of 1518 bytes.
Rx Total Errors	Total number of receive errors.
Rx CRC Errors	Number of packets with a CRC error.
Rx Input Drop Packets	Number of received packets dropped before input.
Rx Input Abort Packets	Number of received packets aborted before input.
Tx Pre Hdlc Bytes	Number of bytes transmitted prior to the bytes HLDC encapsulation by the policy engine.
Tx Post Hdlc Bytes	Number of bytes transmitted after the bytes HLDC encapsulation by the policy engine.
Tx Packets	Number of packets transmitted since the last counter reset.
Port Drop Counts	Number of received frames dropped at the port level.

15.7 Performance Monitoring for Optical Cards

The following sections define performance monitoring parameters and definitions for the OC-3, OC-12, OC-48, OC-192, TXP_MR-10G, TXP_MR_2.5G, TXPP_MR_2.5G, and MXP_2.5G_10G optical cards.

15.7.1 OC-3 Card Performance Monitoring Parameters

Figure 15-11 shows the signal types that support near-end and far-end PMs. Figure 15-12 on page 15-36 shows where overhead bytes detected on the ASICs produce performance monitoring parameters for the OC-3 card.

Figure 15-11 Monitored Signal Types for the OC-3 Card

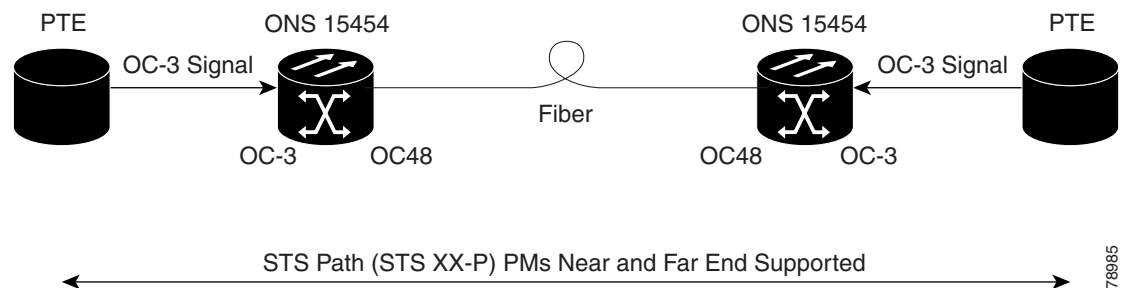

Note

The XX in Figure 15-11 represents all PMs listed in Table 15-43 on page 15-36 through Table 15-50 on page 15-41 with the given prefix and/or suffix.

Figure 15-12 PM Read Points on the OC-3 Card

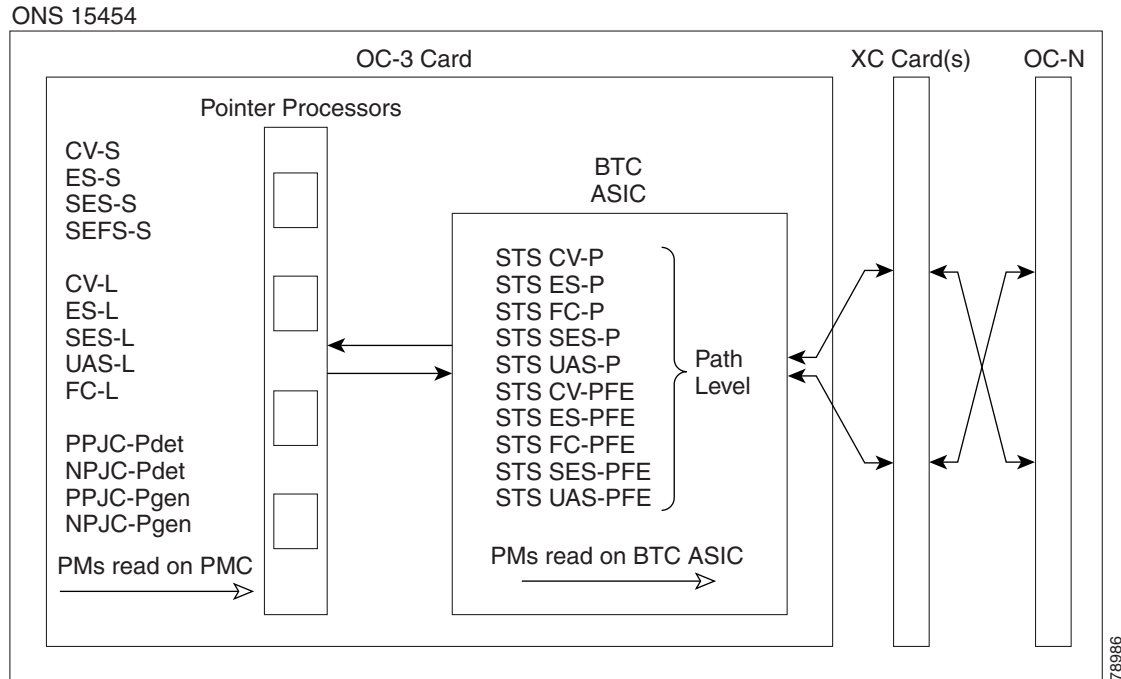
**Note**

For PM locations relating to protection switch counts, see the Telcordia GR-253-CORE document.

The PM parameters for the OC-3 cards are described in Table 15-43 through Table 15-50 on page 15-41.

Table 15-43 Near-End Section PMs for the OC-3 Card

Parameter	Definition
CV-S	Section Coding Violation (CV-S) is a count of BIP errors detected at the section-layer (that is, using the B1 byte in the incoming SONET signal). Up to eight section BIP errors can be detected per STS-N frame, with each error incrementing the current CV-S second register.
ES-S	Section Errored Seconds (ES-S) is a count of the number of seconds when at least one section-layer BIP error was detected or an SEF or LOS defect was present.
SES-S	Section Severely Errored Seconds (SES-S) is a count of the seconds when K (see GR-253 for value) or more section-layer BIP errors were detected or an SEF or LOS defect was present.
SEFS-S	Section Severely Errored Framing Seconds (SEFS-S) is a count of the seconds when an SEF defect was present. An SEF defect is expected to be present during most seconds when an LOS or LOF defect is present. However, there can be situations when the SEFS-S parameter is only incremented based on the presence of the SEF defect.

Table 15-44 Near-End Line Layer PMs for the OC-3 Card

Parameter	Definition
CV-L	Near-End Line Code Violation (CV-L) is a count of BIP errors detected at the line-layer (that is, using the B2 bytes in the incoming SONET signal). Up to 8 x N BIP errors can be detected per STS-N frame; each error increments the current CV-L second register.
ES-L	Near-End Line Errored Seconds (ES-L) is a count of the seconds when at least one line-layer BIP error was detected or an AIS-L defect was present.
SES-L	Near-End Line Severely Errored Seconds (SES-L) is a count of the seconds when K (see GR-253-CORE for values) or more line-layer BIP errors were detected or an AIS-L defect was present.
UAS-L	Near-End Line Unavailable Seconds (UAS-L) is a count of the seconds when the line is unavailable. A line becomes unavailable when ten consecutive seconds occur that qualify as SES-Ls, and it continues to be unavailable until ten consecutive seconds occur that do not qualify as SES-Ls.
FC-L	Near-End Line Failure Count (FC-L) is a count of the number of near-end line failure events. A failure event begins when an AIS-L failure is declared or when a lower-layer traffic-related, near-end failure is declared. This failure event ends when the failure is cleared. A failure event that begins in one period and ends in another period is counted only in the period where it begins.

**Note**

For information about troubleshooting path protection switch counts, refer to the alarm troubleshooting information in the *Cisco ONS 15454 Troubleshooting Guide*. For information about creating circuits that perform a switch, see Chapter 10, “Circuits and Tunnels.”

Table 15-45 Near-End Line Layer PMs for the OC-3 Cards

Parameter	Definition
PSC (1+1 protection)	<p>In a 1 + 1 protection scheme for a working card, Protection Switching Count (PSC) is a count of the number of times service switches from a working card to a protection card plus the number of times service switches back to the working card.</p> <p>For a protection card, PSC is a count of the number of times service switches to a working card from a protection card plus the number of times service switches back to the protection card. The PSC PM is only applicable if revertive line-level protection switching is used.</p> <p>Note BLSR is not supported on the OC-3 card; therefore, the PSC-W, PSC-S, and PSC-R PMs do not increment.</p>
PSD	<p>Protection Switching Duration (PSD) applies to the length of time, in seconds, that service is carried on another line. For a working line, PSD is a count of the number of seconds that service was carried on the protection line.</p> <p>For the protection line, PSD is a count of the seconds that the line was used to carry service. The PSD PM is only applicable if revertive line-level protection switching is used.</p> <p>Note BLSR is not supported on the OC-3 card; therefore, the PSD-W, PSD-S, and PSD-R PMs do not increment.</p>

**Note**

In CTC, the count fields for PPJC and NPJC PM parameters appear white and blank unless they are enabled on the Provisioning > Line tabs. See the “Pointer Justification Count Performance Monitoring” section on page 3.

Table 15-46 Near-End SONET Path H-Byte PMs for the OC-3 Card

Parameter	Definition
PPJC-Pdet	Positive Pointer Justification Count, STS Path Detected (PPJC-Pdet) is a count of the positive pointer justifications detected on a particular path on an incoming SONET signal.
NPJC-Pdet	Negative Pointer Justification Count, STS Path Detected (NPJC-Pdet) is a count of the negative pointer justifications detected on a particular path on an incoming SONET signal.
PPJC-Pgen	Positive Pointer Justification Count, STS Path Generated (PPJC-Pgen) is a count of the positive pointer justifications generated for a particular path to reconcile the frequency of the SPE with the local clock.
NPJC-Pgen	Negative Pointer Justification Count, STS Path Generated (NPJC-Pgen) is a count of the negative pointer justifications generated for a particular path to reconcile the frequency of the synchronous payload envelope (SPE) with the local clock.

**Note**

SONET path PMs do not count unless IPPM is enabled. See the “Intermediate Path Performance Monitoring” section on page 2.

Table 15-47 Near-End SONET Path PMs for the OC-3 Card

Parameter	Definition
STS CV-P	Near-End STS Path Coding Violations (CV-P) is a count of BIP errors detected at the STS path layer (that is, using the B3 byte). Up to eight BIP errors can be detected per frame; each error increments the current CV-P second register.
STS ES-P	Near-End STS Path Errored Seconds (ES-P) is a count of the seconds when one or more STS path BIP errors were detected. An AIS-P defect (or a lower-layer, traffic-related, near-end defect) or an LOP-P defect can also cause an STS ES-P.
STS FC-P	Near-End STS Path Failure Counts (FC-P) is a count of the number of near-end STS path failure events. A failure event begins with an AIS-P failure, an LOP-P failure, a UNEQ-P failure, or a TIM-P failure is declared, or if the STS PTE that is monitoring the path supports ERDI-P for that path. The failure event ends when these failures are cleared.
STS SES-P	Near-End STS Path Severely Errored Seconds (SES-P) is a count of the seconds when K (2400) or more STS path BIP errors were detected. An AIS-P defect (or a lower-layer, traffic-related, near-end defect) or an LOP-P defect can also cause an STS SES-P.
STS UAS-P	Near-End STS Path Unavailable Seconds (UAS-P) is a count of the seconds when the STS path was unavailable. An STS path becomes unavailable when ten consecutive seconds occur that qualify as SES-Ps, and it continues to be unavailable until ten consecutive seconds occur that do not qualify as SES-Ps.

Table 15-48 Far-End Line Layer PMs for the OC-3 Card

Parameter	Definition
CV-LFE	Far-End Line Code Violation (CV-LFE) is a count of BIP errors detected by the far-end line terminating equipment (LTE) and reported back to the near-end LTE using the REI-L indication in the line overhead. For SONET signals at rates below OC-48, up to 8 x N BIP errors per STS-N frame can be indicated using the REI-L. For OC-48 signals, up to 255 BIP errors per STS-N frame can be indicated. The current CV-L second register is incremented for each BIP error indicated by the incoming REI-L.
ES-LFE	Far-End Line Errored Seconds (ES-LFE) is a count of the seconds when at least one line-layer BIP error was reported by the far-end LTE or an RDI-L defect was present.
SES-LFE	Far-End Line Severely Errored Seconds (SES-LFE) is a count of the seconds when K (see GR-253-CORE for values) or more line-layer BIP errors were reported by the far-end LTE or an RDI-L defect was present.

Table 15-48 Far-End Line Layer PMs for the OC-3 Card (continued)

Parameter	Definition
UAS-LFE	Far-End Line Unavailable Seconds (UAS-LFE) is a count of the seconds when the line is unavailable at the far end. A line becomes unavailable at the far end when ten consecutive seconds occur that qualify as SES-LFEs and it continues to be unavailable until ten consecutive seconds occur that do not qualify as SES-LFEs.
FC-LFE	Far-End Line Failure Count (FC-LFE) is a count of the number of far-end line failure events. A failure event begins when RFI-L failure is declared, and it ends when the RFI-L failure clears. A failure event that begins in one period and ends in another period is counted only in the period where it began.

Table 15-49 Near-End SONET Path H-Byte PMs for the OC-3 Card

Parameter	Definition
Note	On CTC, the count fields for PPJC and NPJC PMs appear white and blank unless they are enabled on the Provisioning > Line tabs.
PPJC-Pdet	Positive Pointer Justification Count, STS Path Detected (PPJC-Pdet) is a count of the positive pointer justifications detected on a particular path on an incoming SONET signal.
NPJC-Pdet	Negative Pointer Justification Count, STS Path Detected (NPJC-Pdet) is a count of the negative pointer justifications detected on a particular path on an incoming SONET signal.
PPJC-Pgen	Positive Pointer Justification Count, STS Path Generated (PPJC-Pgen) is a count of the positive pointer justifications generated for a particular path to reconcile the frequency of the SPE with the local clock.
NPJC-Pgen	Negative Pointer Justification Count, STS Path Generated (NPJC-Pgen) is a count of the negative pointer justifications generated for a particular path to reconcile the frequency of the synchronous payload envelope (SPE) with the local clock.

**Note**

SONET path PMs do not count unless IPPM is enabled. See the “Intermediate Path Performance Monitoring” section on page 2.

Table 15-50 Far-End SONET Path PMs for the OC-3 Card

Parameter	Definition
STS CV-PFE	Far-End STS Path Coding Violations (CV-PFE) is a count of BIP errors detected at the STS path layer (that is, using the B3 byte). Up to eight BIP errors can be detected per frame; each error increments the current CV-PFE second register.
STS ES-PFE	Far-End STS Path Errored Seconds (ES-PFE) is a count of the seconds when one or more STS path BIP errors were detected. An AIS-P defect (or a lower-layer, traffic-related, far-end defect) or an LOP-P defect can also cause an STS ES-PFE.
STS FC-PFE	Far-End STS Path Failure Counts (FC-PFE) is a count of the number of far-end STS path failure events. A failure event begins with an AIS-P failure, an LOP-P failure, a UNEQ-P failure, or a TIM-P failure is declared, or if the STS PTE that is monitoring the path supports ERDI-P for that path. The failure event ends when these failures are cleared.
STS SES-PFE	Far-End STS Path Severely Errored Seconds (SES-PFE) is a count of the seconds when K (2400) or more STS path BIP errors were detected. An AIS-P defect (or a lower-layer, traffic-related, far-end defect) or an LOP-P defect can also cause an STS SES-PFE.
STS UAS-PFE	Far-End STS Path Unavailable Seconds (UAS-PFE) is a count of the seconds when the STS path was unavailable. An STS path becomes unavailable when ten consecutive seconds occur that qualify as SES-PFEs, and it continues to be unavailable until ten consecutive seconds occur that do not qualify as SES-PFEs.

15.7.2 OC-12 Card Performance Monitoring Parameters

Figure 15-13 shows the signal types that support near-end and far-end PMs. Figure 15-14 on page 15-42 shows where overhead bytes detected on the ASICs produce performance monitoring parameters for the OC-12 card.

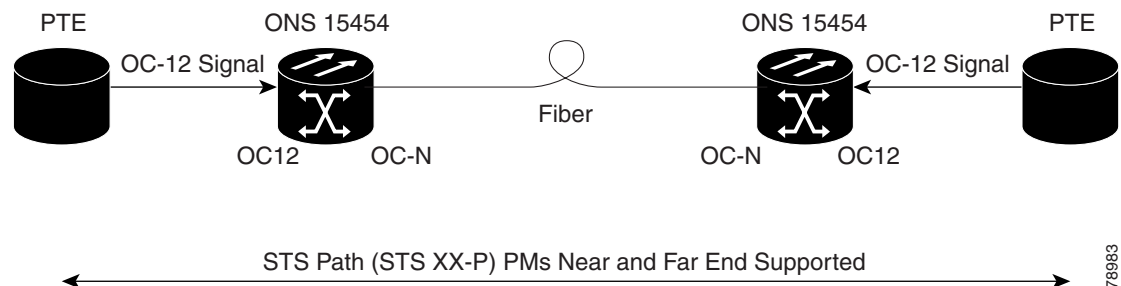
Figure 15-13 Monitored Signal Types for the OC-12 Card**Note**

PMs on the protect STS are not supported for BLSR. The XX in Figure 15-13 represents all PMs listed in Table 15-51 on page 15-42 through Table 15-57 on page 15-46 with the given prefix and/or suffix.

Figure 15-14 PM Read Points on the OC-12 Card

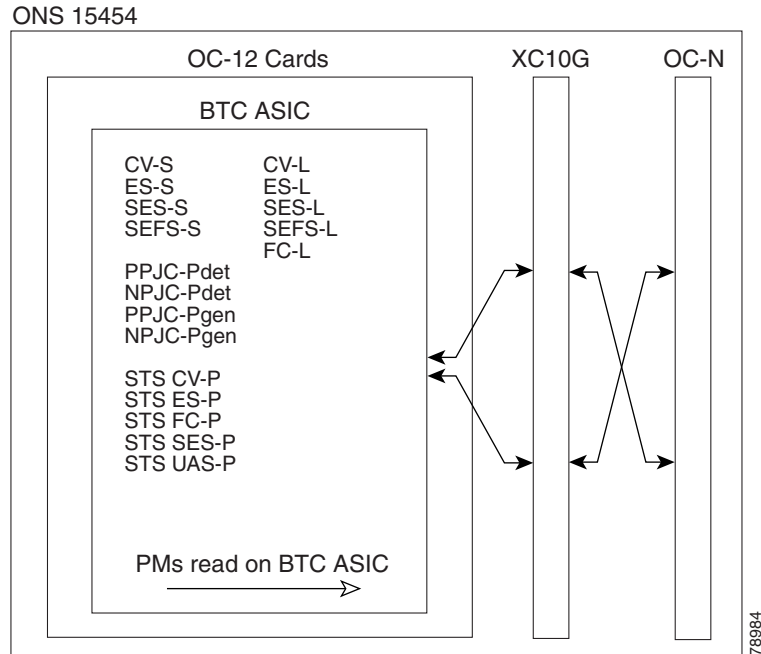
**Note**

For PM locations relating to protection switch counts, see the Telcordia GR-1230-CORE document.

The PM parameters for the OC-12 cards are described in Table 15-51 through Table 15-57 on page 15-46.

Table 15-51 Near-End Section PMs for the OC-12 Card

Parameter	Definition
CV-S	Section Coding Violation (CV-S) is a count of BIP errors detected at the section-layer (that is, using the B1 byte in the incoming SONET signal). Up to eight section BIP errors can be detected per STS-N frame; each error increments the current CV-S second register.
ES-S	Section Errored Seconds (ES-S) is a count of the number of seconds when at least one section-layer BIP error was detected or an SEF or LOS defect was present.
SES-S	Section Severely Errored Seconds (SES-S) is a count of the seconds when K (see GR-253 for value) or more section-layer BIP errors were detected or an SEF or LOS defect was present.
SEFS-S	Section Severely Errored Framing Seconds (SEFS-S) is a count of the seconds when an SEF defect was present. An SEF defect is expected to be present during most seconds when an LOS or LOF defect is present. However, there may be situations when the SEFS-S parameter is only incremented based on the presence of an SEF defect.

Table 15-52 Near-End Line Layer PMs for the OC-12 Card

Parameter	Definition
CV-L	Near-End Line Code Violation (CV-L) is a count of BIP errors detected at the line-layer (that is, using the B2 bytes in the incoming SONET signal). Up to 8 x N BIP errors can be detected per STS-N frame; each error increments the current CV-L second register.
ES-L	Near-End Line Errored Seconds (ES-L) is a count of the seconds when at least one line-layer BIP error was detected or an AIS-L defect was present.
SES-L	Near-End Line Severely Errored Seconds (SES-L) is a count of the seconds when K (see GR-253 for values) or more line-layer BIP errors were detected or an AIS-L defect was present.
UAS-L	Near-End Line Unavailable Seconds (UAS-L) is a count of the seconds when the line is unavailable. A line becomes unavailable when ten consecutive seconds occur that qualify as SES-Ls, and it continues to be unavailable until ten consecutive seconds occur that do not qualify as SES-Ls.
FC-L	Near-End Line Failure Count (FC-L) is a count of the number of near-end line failure events. A failure event begins when an AIS-L failure or a lower-layer traffic-related, near-end failure is declared. This failure event ends when the failure is cleared. A failure event that begins in one period and ends in another period is counted only in the period where it begins.

Table 15-53 Near-End SONET Path H-Byte PMs for the OC-12 Card

Parameter	Definition
Note	On CTC, the count fields for PPJC and NPJC PMs appear white and blank unless they are enabled on the Provisioning > Line tabs.
PPJC-Pdet	Positive Pointer Justification Count, STS Path Detected (PPJC-Pdet) is a count of the positive pointer justifications detected on a particular path on an incoming SONET signal.
NPJC-Pdet	Negative Pointer Justification Count, STS Path Detected (NPJC-Pdet) is a count of the negative pointer justifications detected on a particular path on an incoming SONET signal.
PPJC-Pgen	Positive Pointer Justification Count, STS Path Generated (PPJC-Pgen) is a count of the positive pointer justifications generated for a particular path to reconcile the frequency of the SPE with the local clock.
NPJC-Pgen	Negative Pointer Justification Count, STS Path Generated (NPJC-Pgen) is a count of the negative pointer justifications generated for a particular path to reconcile the frequency of the synchronous payload envelope (SPE) with the local clock.

**Note**

For information about troubleshooting path protection switch counts, refer to the alarm troubleshooting information in the *Cisco ONS 15454 Troubleshooting Guide*. For information about creating circuits that perform a switch, see Chapter 10, “Circuits and Tunnels.”

Table 15-54 Near-End Line Layer PMs for the OC-12 Card

Parameter	Definition
PSC (BLSR)	<p>For a protect line in a two-fiber ring, Protection Switching Count (PSC) refers to the number of times a protection switch has occurred either to a particular span’s line protection or away from a particular span’s line protection. Therefore, if a protection switch occurs on a two-fiber BLSR, the PSC of the protection span to which the traffic is switched will increment, and when the switched traffic returns to its original working span from the protect span, the PSC of the protect span increments again.</p> <p>Note Four-fiber BLSR is not supported on the OC-12 card; therefore, the PSC-S, and PSC-R PMs do not increment.</p>
PSC (1+1 protection)	<p>In a 1 + 1 protection scheme for a working card, Protection Switching Count (PSC) is a count of the number of times service switches from a working card to a protection card plus the number of times service switches back to the working card.</p> <p>For a protection card, PSC is a count of the number of times service switches to a working card from a protection card plus the number of times service switches back to the protection card. The PSC PM is only applicable if revertive line-level protection switching is used.</p>
PSD	<p>Protection Switching Duration (PSD) applies to the length of time, in seconds, that service is carried on another line. For a working line, PSD is a count of the number of seconds that service was carried on the protection line.</p> <p>For the protection line, PSD is a count of the seconds that the line was used to carry service. The PSD PM is only applicable if revertive line-level protection switching is used.</p> <p>Note Four-fiber BLSR is not supported on the OC-12 card; therefore, the PSD-S, and PSD-R PMs do not increment.</p>
PSC-W	<p>For a working line in a two-fiber BLSR, Protection Switching Count-Working (PSC-W) is a count of the number of times traffic switches away from the working capacity in the failed line and back to the working capacity after the failure is cleared. PSC-W increments on the failed working line and PSC increments on the active protect line.</p>
PSD-W	<p>For a working line in a two-fiber BLSR, Protection Switching Duration-Working (PSD-W) is a count of the number of seconds that service was carried on the protection line. PSD-W increments on the failed working line and PSD increments on the active protect line.</p>

**Note**

SONET path PMs do not count unless IPPM is enabled. See the “Intermediate Path Performance Monitoring” section on page 2.

Table 15-55 Near-End SONET Path PMs for the OC-12 Card

Parameter	Definition
STS CV-P	Near-End STS Path Coding Violations (CV-P) is a count of BIP errors detected at the STS path layer (that is, using the B3 byte). Up to eight BIP errors can be detected per frame; each error increments the current CV-P second register.
STS ES-P	Near-End STS Path Errored Seconds (ES-P) is a count of the seconds when at least one STS path BIP error was detected. An AIS-P defect (or a lower-layer, traffic-related, near-end defect) or an LOP-P defect can also cause an STS ES-P.
STS FC-P	Near-End STS Path Failure Counts (FC-P) is a count of the number of near-end STS path failure events. A failure event begins with an AIS-P failure, an LOP-P failure, a UNEQ-P failure or a TIM-P failure is declared, or if the STS PTE that is monitoring the path supports ERDI-P for that path. The failure event ends when these failures are cleared.
STS SES-P	Near-End STS Path Severely Errored Seconds (SES-P) is a count of the seconds when K (2400) or more STS path BIP errors were detected. An AIS-P defect (or a lower-layer, traffic-related, near-end defect) or an LOP-P defect can also cause an STS SES-P.
STS UAS-P	Near-End STS Path Unavailable Seconds (UAS-P) is a count of the seconds when the STS path was unavailable. An STS path becomes unavailable when ten consecutive seconds occur that qualify as SES-Ps, and it continues to be unavailable until ten consecutive seconds occur that do not qualify as SES-Ps.

Table 15-56 Far-End Line Layer PMs for the OC-12 Card

Parameter	Definition
CV-LFE	Far-End Line Code Violation (CV-LFE) is a count of BIP errors detected by the far-end line terminating equipment (LTE) and reported back to the near-end LTE using the REI-L indication in the line overhead. For SONET signals at rates below OC-48, up to 8 x N BIP errors per STS-N frame can be indicated using the REI-L. For OC-48 signals, up to 255 BIP errors per STS-N frame can be indicated. The current CV-L second register is incremented for each BIP error indicated by the incoming REI-L.
ES-LFE	Far-End Line Errored Seconds (ES-LFE) is a count of the seconds when at least one line-layer BIP error was reported by the far-end LTE or an RDI-L defect was present.
SES-LFE	Far-End Line Severely Errored Seconds (SES-LFE) is a count of the seconds when K (see GR-253-CORE for values) or more line-layer BIP errors were reported by the far-end LTE or an RDI-L defect was present.

Table 15-56 Far-End Line Layer PMs for the OC-12 Card (continued)

Parameter	Definition
UAS-LFE	Far-End Line Unavailable Seconds (UAS-LFE) is a count of the seconds when the line is unavailable at the far end. A line becomes unavailable at the far end when ten consecutive seconds occur that qualify as SES-LFEs, and it continues to be unavailable until ten consecutive seconds occur that do not qualify as SES-LFEs.
FC-LFE	Far-End Line Failure Count (FC-LFE) is a count of the number of far-end line failure events. A failure event begins when RFI-L failure is declared and ends when the RFI-L failure clears. A failure event that begins in one period and ends in another period is counted only in the period where it began.

**Note**

SONET path PMs do not count unless IPPM is enabled. See the “Intermediate Path Performance Monitoring” section on page 2.

Table 15-57 Far-End SONET Path PMs for the OC-12 Card

Parameter	Definition
STS CV-PFE	Far-End STS Path Coding Violations (CV-PFE) is a count of BIP errors detected at the STS path layer (that is, using the B3 byte). Up to eight BIP errors can be detected per frame; each error increments the current CV-PFE second register.
STS ES-PFE	Far-End STS Path Errored Seconds (ES-PFE) is a count of the seconds when at least one STS path BIP error was detected. An AIS-P defect (or a lower-layer, traffic-related, far-end defect) or an LOP-P defect can also cause an STS ES-PFE.
STS FC-PFE	Far-End STS Path Failure Counts (FC-PFE) is a count of the number of far-end STS path failure events. A failure event begins with an AIS-P failure, an LOP-P failure, a UNEQ-P failure or a TIM-P failure is declared, or if the STS PTE that is monitoring the path supports ERDI-P for that path. The failure event ends when these failures are cleared.
STS SES-PFE	Far-End STS Path Severely Errored Seconds (SES-PFE) is a count of the seconds when K (2400) or more STS path BIP errors were detected. An AIS-P defect (or a lower-layer, traffic-related, far-end defect) or an LOP-P defect can also cause an STS SES-PFE.
STS UAS-PFE	Far-End STS Path Unavailable Seconds (UAS-PFE) is a count of the seconds when the STS path was unavailable. An STS path becomes unavailable when ten consecutive seconds occur that qualify as SES-PFEs, and it continues to be unavailable until ten consecutive seconds occur that do not qualify as SES-PFEs.

15.7.3 OC-48 and OC-192 Card Performance Monitoring Parameters

Figure 15-15 shows the signal types that support near-end and far-end PMs. Figure 15-16 shows where overhead bytes detected on the ASICs produce performance monitoring parameters for the OC-48 and OC-192 cards.

Figure 15-15 Monitored Signal Types for the OC-48 and OC-192 Cards

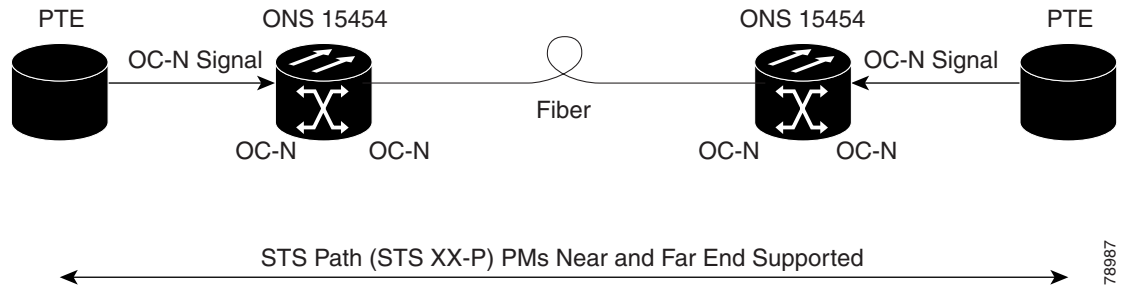

Note

PMs on the protect STS are not supported for BLSR. The XX in Figure 15-15 represents all PMs listed in Table 15-58 on page 15-48 through Table 15-64 on page 15-52 with the given prefix and/or suffix.

Figure 15-16 PM Read Points on the OC-48 and OC-192 Cards

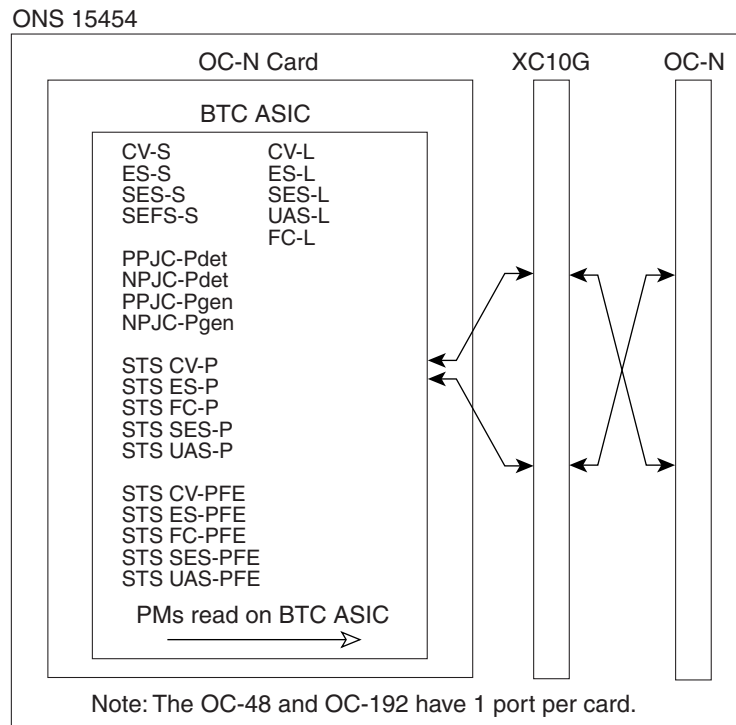

Note

For PM locations relating to protection switch counts, see the Telcordia GR-1230-CORE document.

The PM parameters for the OC-48 and OC-192 cards are described in Table 15-58 through Table 15-64 on page 15-52.

Table 15-58 Near-End Section PMs for the OC-48 and OC-192 Cards

Parameter	Definition
CV-S	Section Coding Violation (CV-S) is a count of BIP errors detected at the section-layer (that is, using the B1 byte in the incoming SONET signal). Up to eight section BIP errors can be detected per STS-N frame; each error increments the current CV-S second register.
ES-S	Section Errored Seconds (ES-S) is a count of the number of seconds when at least one section-layer BIP error was detected or an SEF or LOS defect was present.
SES-S	Section Severely Errored Seconds (SES-S) is a count of the seconds when K (see GR-253 for value) or more section-layer BIP errors were detected or an SEF or LOS defect was present.
SEFS-S	Section Severely Errored Framing Seconds (SEFS-S) is a count of the seconds when an SEF defect was present. An SEF defect is expected to be present during most seconds when an LOS or LOF defect is present. However, there may be situations when the SEFS-S parameter is only incremented based on the presence of an SEF defect.

Table 15-59 Near-End Line Layer PMs for the OC-48 and OC-192 Cards

Parameter	Definition
CV-L	Near-End Line Code Violation (CV-L) is a count of BIP errors detected at the line-layer (that is, using the B2 bytes in the incoming SONET signal). Up to 8 x N BIP errors can be detected per STS-N frame; each error increments the current CV-L second register.
ES-L	Near-End Line Errored Seconds (ES-L) is a count of the seconds when at least one line-layer BIP error was detected or an AIS-L defect was present.
SES-L	Near-End Line Severely Errored Seconds (SES-L) is a count of the seconds when K (see GR-253 for values) or more line-layer BIP errors were detected or an AIS-L defect was present.
UAS-L	Near-End Line Unavailable Seconds (UAS-L) is a count of the seconds when the line is unavailable. A line becomes unavailable when ten consecutive seconds occur that qualify as SES-Ls, and it continues to be unavailable until ten consecutive seconds occur that do not qualify as SES-Ls.
FC-L	Near-End Line Failure Count (FC-L) is a count of the number of near-end line failure events. A failure event begins when an AIS-L failure or a lower-layer traffic-related, near-end failure is declared. This failure event ends when the failure is cleared. A failure event that begins in one period and ends in another period is counted only in the period where it begins.

**Note**

In CTC, the count fields for PPJC and NPJC PM parameters appear white and blank unless they are enabled on the Provisioning > Line tabs. See the “Pointer Justification Count Performance Monitoring” section on page 3.

Table 15-60 Near-End SONET Path H-byte PMs for the OC-48 and OC-192 Cards

Parameter	Definition
PPJC-Pdet	Positive Pointer Justification Count, STS Path Detected (PPJC-Pdet) is a count of the positive pointer justifications detected on a particular path on an incoming SONET signal.
NPJC-Pdet	Negative Pointer Justification Count, STS Path Detected (NPJC-Pdet) is a count of the negative pointer justifications detected on a particular path on an incoming SONET signal.
PPJC-Pgen	Positive Pointer Justification Count, STS Path Generated (PPJC-Pgen) is a count of the positive pointer justifications generated for a particular path to reconcile the frequency of the SPE with the local clock.
NPJC-Pgen	Negative Pointer Justification Count, STS Path Generated (NPJC-Pgen) is a count of the negative pointer justifications generated for a particular path to reconcile the frequency of the synchronous payload envelope (SPE) with the local clock.

**Note**

For information about troubleshooting path protection switch counts, refer to the alarm troubleshooting information in the *Cisco ONS 15454 Troubleshooting Guide*. For information about creating circuits that perform a switch, see Chapter 10, “Circuits and Tunnels.”

Table 15-61 Near-End Line Layer PMs for the OC-48 and OC-192 Cards

Parameter	Definition
PSC (BLSR)	For a protect line in a two-fiber ring, Protection Switching Count (PSC) refers to the number of times a protection switch has occurred either to a particular span’s line protection or away from a particular span’s line protection. Therefore, if a protection switch occurs on a two-fiber BLSR, the PSC of the protection span to which the traffic is switched will increment, and when the switched traffic returns to its original working span from the protect span, the PSC of the protect span will increment again.
PSC (1+1 protection)	In a 1 + 1 protection scheme for a working card, Protection Switching Count (PSC) is a count of the number of times service switches from a working card to a protection card plus the number of times service switches back to the working card. For a protection card, PSC is a count of the number of times service switches to a working card from a protection card plus the number of times service switches back to the protection card. The PSC PM is only applicable if revertive line-level protection switching is used.

Table 15-61 Near-End Line Layer PMs for the OC-48 and OC-192 Cards (continued)

Parameter	Definition
PSD	<p>Protection Switching Duration (PSD) applies to the length of time, in seconds, that service is carried on another line. For a working line, PSD is a count of the number of seconds that service was carried on the protection line.</p> <p>For the protection line, PSD is a count of the seconds that the line was used to carry service. The PSD PM is only applicable if revertive line-level protection switching is used.</p>
PSC-W	<p>For a working line in a two-fiber BLSR, Protection Switching Count-Working (PSC-W) is a count of the number of times traffic switches away from the working capacity in the failed line and back to the working capacity after the failure is cleared. PSC-W increments on the failed working line and PSC increments on the active protect line.</p> <p>For a working line in a four-fiber BLSR, PSC-W is a count of the number of times service switches from a working line to a protection line plus the number of times it switches back to the working line. PSC-W increments on the failed line and PSC-R or PSC-S increments on the active protect line.</p>
PSD-W	For a working line in a two-fiber BLSR, Protection Switching Duration-Working (PSD-W) is a count of the number of seconds that service was carried on the protection line. PSD-W increments on the failed working line and PSD increments on the active protect line.
PSC-S	In a four-fiber BLSR, Protection Switching Count-Span (PSC-S) is a count of the number of times service switches from a working line to a protection line plus the number of times it switches back to the working line. A count is only incremented if span switching is used.
PSD-S	In a four-fiber BLSR, Protection Switching Duration-Span (PSD-S) is a count of the seconds that the protection line was used to carry service. A count is only incremented if span switching is used.
PSC-R	In a four-fiber BLSR, Protection Switching Count-Ring (PSC-R) is a count of the number of times service switches from a working line to a protection line plus the number of times it switches back to a working line. A count is only incremented if ring switching is used.
PSD-R	In a four-fiber BLSR, Protection Switching Duration-Ring (PSD-R) is a count of the seconds that the protection line was used to carry service. A count is only incremented if ring switching is used.

**Note**

SONET path PMs do not count unless IPPM is enabled. See the “Intermediate Path Performance Monitoring” section on page 2.

Table 15-62 Near-End SONET Path PMs for the OC-48 and OC-192 Cards

Parameter	Definition
STS CV-P	Near-End STS Path Coding Violations (CV-P) is a count of BIP errors detected at the STS path layer (that is, using the B3 byte). Up to eight BIP errors can be detected per frame; each error increments the current CV-P second register.
STS ES-P	Near-End STS Path Errored Seconds (ES-P) is a count of the seconds when at least one STS path BIP error was detected. An AIS-P defect (or a lower-layer, traffic-related, near-end defect) or an LOP-P defect can also cause an STS ES-P.
STS FC-P	Near-End STS Path Failure Counts (FC-P) is a count of the number of near-end STS path failure events. A failure event begins with an AIS-P failure, an LOP-P failure, a UNEQ-P failure or a TIM-P failure is declared, or if the STS PTE that is monitoring the path supports ERDI-P for that path. The failure event ends when these failures are cleared.
STS SES-P	Near-End STS Path Severely Errored Seconds (SES-P) is a count of the seconds when K (2400) or more STS path BIP errors were detected. An AIS-P defect (or a lower-layer, traffic-related, near-end defect) or an LOP-P defect can also cause an STS SES-P.
STS UAS-P	Near-End STS Path Unavailable Seconds (UAS-P) is a count of the seconds when the STS path was unavailable. An STS path becomes unavailable when ten consecutive seconds occur that qualify as SES-Ps, and it continues to be unavailable until ten consecutive seconds occur that do not qualify as SES-Ps.

Table 15-63 Far-End Line Layer PMs for the OC-48 and OC-192 Cards

Parameter	Definition
CV-LFE	Far-End Line Code Violation (CV-LFE) is a count of BIP errors detected by the far-end line terminating equipment (LTE) and reported back to the near-end LTE using the REI-L indication in the line overhead. For SONET signals at rates below OC-48, up to 8 x N BIP errors per STS-N frame can be indicated using the REI-L. For OC-48 signals, up to 255 BIP errors per STS-N frame can be indicated. The current CV-L second register is incremented for each BIP error indicated by the incoming REI-L.
ES-LFE	Far-End Line Errored Seconds (ES-LFE) is a count of the seconds when at least one line-layer BIP error was reported by the far-end LTE or an RDI-L defect was present.
SES-LFE	Far-End Line Severely Errored Seconds (SES-LFE) is a count of the seconds when K (see GR-253-CORE for values) or more line-layer BIP errors were reported by the far-end LTE or an RDI-L defect was present.

Table 15-63 Far-End Line Layer PMs for the OC-48 and OC-192 Cards (continued)

Parameter	Definition
UAS-LFE	Far-End Line Unavailable Seconds (UAS-LFE) is a count of the seconds when the line is unavailable at the far end. A line becomes unavailable at the far end when ten consecutive seconds occur that qualify as SES-LFEs, and it continues to be unavailable until ten consecutive seconds occur that do not qualify as SES-LFEs.
FC-LFE	Far-End Line Failure Count (FC-LFE) is a count of the number of far-end line failure events. A failure event begins when RFI-L failure is declared and ends when the RFI-L failure clears. A failure event that begins in one period and ends in another period is counted only in the period where it began.

**Note**

SONET path PMs do not count unless IPPM is enabled. See the “Intermediate Path Performance Monitoring” section on page 2.

Table 15-64 Far-End SONET Path PMs for the OC-48 and OC-192 Cards

Parameter	Definition
STS CV-PFE	Far-End STS Path Coding Violations (CV-PFE) is a count of BIP errors detected at the STS path layer (that is, using the B3 byte). Up to eight BIP errors can be detected per frame; each error increments the current CV-PFE second register.
STS ES-PFE	Far-End STS Path Errored Seconds (ES-PFE) is a count of the seconds when at least one STS path BIP error was detected. An AIS-P defect (or a lower-layer, traffic-related, far-end defect) or an LOP-P defect can also cause an STS ES-PFE.
STS FC-PFE	Far-End STS Path Failure Counts (FC-PFE) is a count of the number of far-end STS path failure events. A failure event begins with an AIS-P failure, an LOP-P failure, a UNEQ-P failure or a TIM-P failure is declared, or if the STS PTE that is monitoring the path supports ERDI-P for that path. The failure event ends when these failures are cleared.
STS SES-PFE	Far-End STS Path Severely Errored Seconds (SES-PFE) is a count of the seconds when K (2400) or more STS path BIP errors were detected. An AIS-P defect (or a lower-layer, traffic-related, far-end defect) or an LOP-P defect can also cause an STS SES-PFE.
STS UAS-PFE	Far-End STS Path Unavailable Seconds (UAS-PFE) is a count of the seconds when the STS path was unavailable. An STS path becomes unavailable when ten consecutive seconds occur that qualify as SES-PFEs, and it continues to be unavailable until ten consecutive seconds occur that do not qualify as SES-PFEs.

15.7.4 TXP_MR_10G Card Performance Monitoring Parameters

Figure 15-17 shows the signal types that support near-end and far-end PMs. Figure 15-18 on page 15-54 shows where overhead bytes detected on the ASICs produce performance monitoring parameters for the TXP_MR_10G card.

Figure 15-17 Monitored Signal Types for TXP_MR_10G Cards

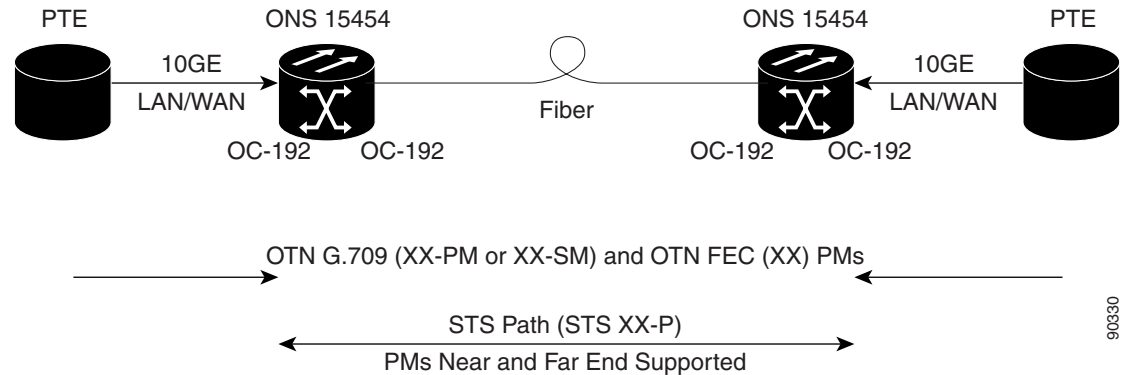

Note

The XX in Figure 15-17 represents all PMs listed in Table 15-65 on page 15-54 through Table 15-69 on page 15-57 with the given prefix and/or suffix.

Figure 15-18 PM Read Points on TXP_MR_10G Cards

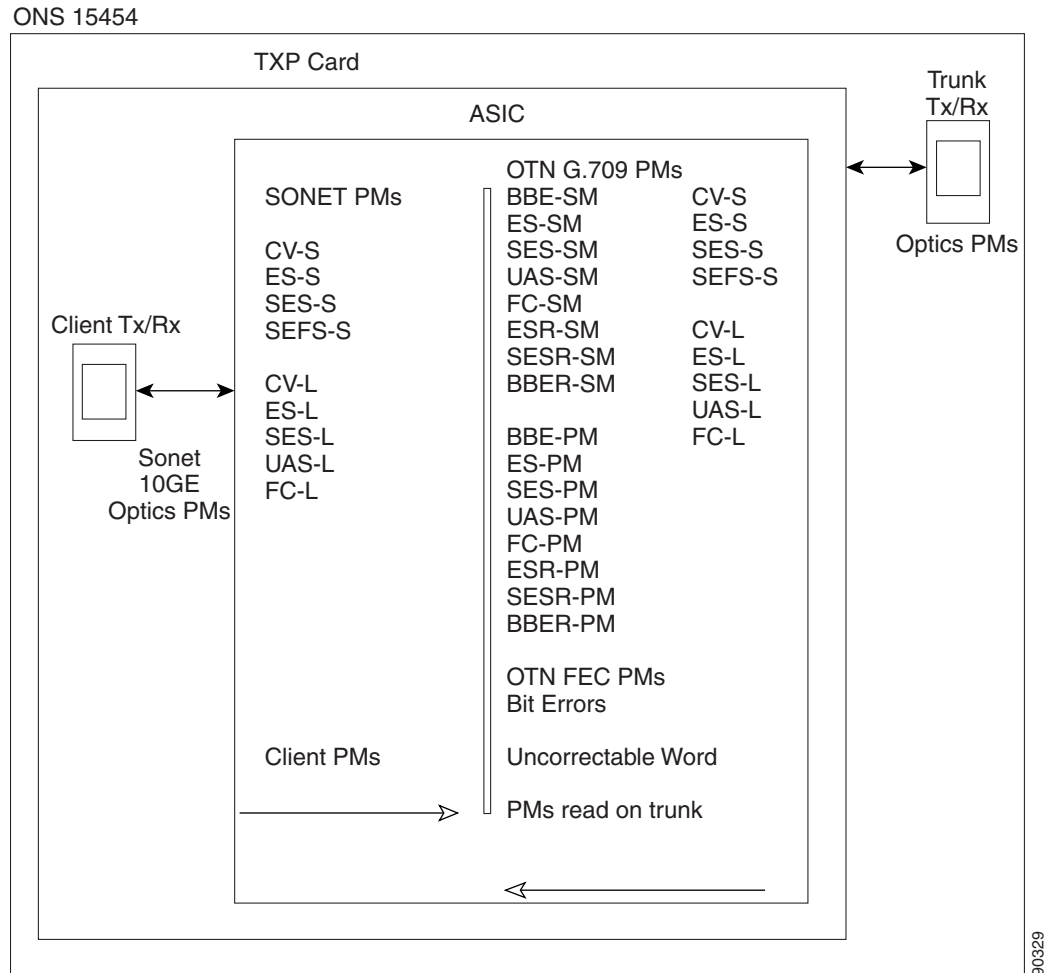

The PM parameters for the TXP_MR_10G cards are described in Table 15-65 on page 15-54 through Table 15-69 on page 15-57.

Table 15-65 Physical Optics PM Parameters for TXP_MR_10G Cards

Parameter	Definition
Laser Bias (Min)	Minimum percentage of laser bias current (%)
Laser Bias (Avg)	Average percentage of laser bias current (%)
Laser Bias (Max)	Maximum percentage of laser bias current (%)
Rx Optical Pwr (Min)	Minimum receive optical power (dBm)
Rx Optical Pwr (Avg)	Average receive optical power (dBm)
Rx Optical Pwr (Max)	Maximum receive optical power (dBm)
Tx Optical Pwr (Min)	Minimum transmit optical power (dBm)
TX Optical Pwr (Avg)	Average transmit optical power (dBm)
Tx Optical Pwr (Max)	Maximum transmit optical power (dBm)

Table 15-66 Near-End or Far-End Section PM Parameters for TXP_MR_10G Cards

Parameter	Definition
CV-S	Section Coding Violation (CV-S) is a count of BIP errors detected at the section-layer (that is, using the B1 byte in the incoming SONET signal). Up to eight section BIP errors can be detected per STS-N frame; each error increments the current CV-S second register.
ES-S	Section Errored Seconds (ES-S) is a count of the number of seconds when at least one section-layer BIP error was detected or an SEF or LOS defect was present.
SES-S	Section Severely Errored Seconds (SES-S) is a count of the seconds when K (see GR-253 for value) or more section-layer BIP errors were detected or an SEF or LOS defect was present.
SEFS-S	Section Severely Errored Framing Seconds (SEFS-S) is a count of the seconds when an SEF defect was present. An SEF defect is expected to be present during most seconds when an LOS or LOF defect is present. However, there may be situations when the SEFS-S parameter is only incremented based on the presence of an SEF defect.

Table 15-67 Near-End or Far-End Line Layer PM Parameters for TXP_MR_10G Cards

Parameter	Definition
CV-L	Line Code Violation (CV-L) is a count of BIP errors detected at the line-layer (that is, using the B2 bytes in the incoming SONET signal). Up to 8 x N BIP errors can be detected per STS-N frame; each error increments the current CV-L second register.
ES-L	Line Errored Seconds (ES-L) is a count of the seconds when at least one line-layer BIP error was detected or an AIS-L defect was present.
SES-L	Line Severely Errored Seconds (SES-L) is a count of the seconds when K (see GR-253 for values) or more line-layer BIP errors were detected or an AIS-L defect was present.
UAS-L	Line Unavailable Seconds (UAS-L) is a count of the seconds when the line is unavailable. A line becomes unavailable when ten consecutive seconds occur that qualify as SES-Ls, and it continues to be unavailable until ten consecutive seconds occur that do not qualify as SES-Ls.
FC-L	Line Failure Count (FC-L) is a count of the number of near-end line failure events. A failure event begins when an AIS-L failure or a lower-layer traffic-related, near-end failure is declared. This failure event ends when the failure is cleared. A failure event that begins in one period and ends in another period is counted only in the period where it begins.

Table 15-68 Near-End or Far-End OTN G.709 PM Parameters for TXP_MR_10G Cards

Parameter	Definition
BBE-SM	Section Monitoring Background Block Errors (BBE-SM) indicates the number of background block errors recorded in the OTN section during the PM time interval.
ES-SM	Section Monitoring Errored Seconds (ES-SM) indicates the errored seconds recorded in the OTN section during the PM time interval.
SES-SM	Section Monitoring Severely Errored Seconds (SES-SM) indicates the severely errored seconds recorded in the OTN section during the PM time interval.
UAS-SM	Section Monitoring Unavailable Seconds (UAS-SM) indicates the unavailable seconds recorded in the OTN section during the PM time interval.
FC-SM	Section Monitoring Failure Counts (FC-SM) indicates the failure counts recorded in the OTN section during the PM time interval.
ESR-SM	Section Monitoring Errored Seconds Ratio (ESR-SM) indicates the errored seconds ratio recorded in the OTN section during the PM time interval.
SESR-SM	Section Monitoring Severely Errored Seconds Ratio (SESR-SM) indicates the severely errored seconds ratio recorded in the OTN section during the PM time interval.
BBER-SM	Section Monitoring Background Block Errors Ratio (BBER-SM) indicates the background block errors ratio recorded in the OTN section during the PM time interval.
BBE-PM	Path Monitoring Background Block Errors (BBE-PM) indicates the number of background block errors recorded in the OTN path during the PM time interval.
ES-PM	Path Monitoring Errored Seconds (ES-PM) indicates the errored seconds recorded in the OTN path during the PM time interval.
SES-PM	Path Monitoring Severely Errored Seconds (SES-PM) indicates the severely errored seconds recorded in the OTN path during the PM time interval.
UAS-PM	Path Monitoring Unavailable Seconds (UAS-PM) indicates the unavailable seconds recorded in the OTN path during the PM time interval.
FC-PM	Path Monitoring Failure Counts (FC-PM) indicates the failure counts recorded in the OTN path during the PM time interval.
ESR-PM	Path Monitoring Errored Seconds Ratio (ESR-PM) indicates the errored seconds ratio recorded in the OTN path during the PM time interval.
SESR-PM	Path Monitoring Severely Errored Seconds Ratio (SESR-PM) indicates the severely errored seconds ratio recorded in the OTN path during the PM time interval.
BBER-PM	Path Monitoring Background Block Errors Ratio (BBER-PM) indicates the background block errors ratio recorded in the OTN path during the PM time interval.

Table 15-69 Near-End or Far-End OTN FEC PM Parameters for the TXP_MR_10G Card

Parameter	Definition
Bit Errors Corrected	The number of bit errors corrected in the DWDM trunk line during the PM time interval.
Uncorrectable Words	The number of uncorrectable words detected in the DWDM trunk line during the PM time interval.

15.7.5 TXP_MR_2.5G Card Performance Monitoring Parameters

Figure 15-19 shows the signal types that support near-end and far-end PMs. Figure 15-20 on page 15-58 shows where overhead bytes detected on the ASICs produce performance monitoring parameters for the TXP_MR_2.5G and TXPP_MR_2.5G cards.

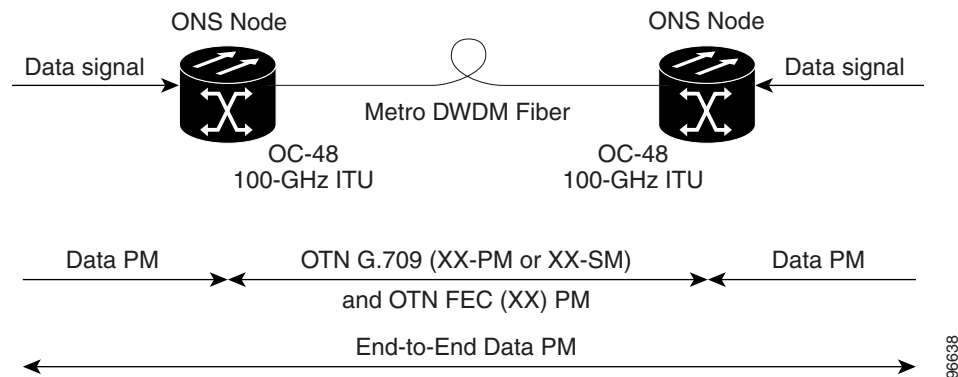
Figure 15-19 Monitored Signal Types for TXP_MR_2.5G and TXPP_MR_2.5G Cards**Note**

The XX in Figure 15-19 represents all PMs listed in Table 15-70 on page 15-58 through Table 15-75 on page 15-61 with the given prefix and/or suffix.

Figure 15-20 PM Read Points on TXP_MR_2.5G and TXPP_MR_2.5G Cards

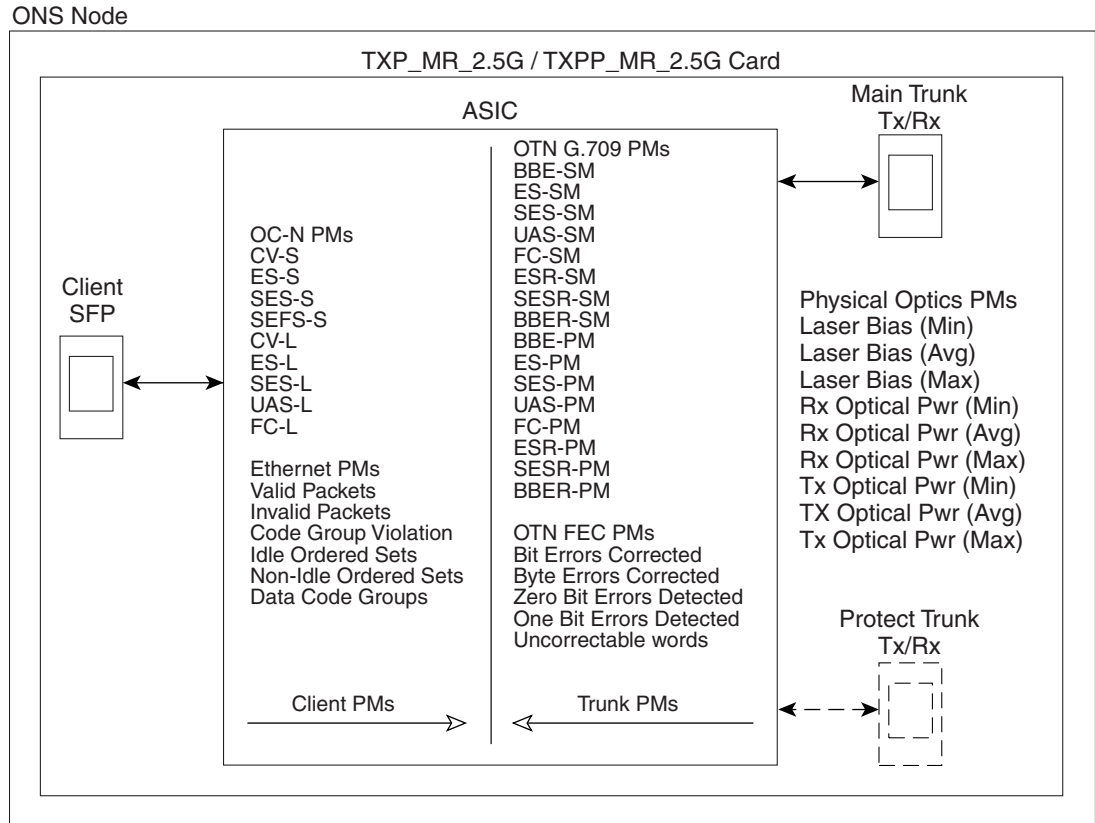

The PM parameters for the TXP_MR_2.5G and TXPP_MR_2.5G cards are described in Table 15-70 through Table 15-75 on page 15-61.

Table 15-70 Optical PM Parameters for TXP_MR_2.5G and TXPP_MR_2.5G Cards

Parameter	Definition
Laser Bias (Min)	Minimum percentage of laser bias current (%)
Laser Bias (Avg)	Average percentage of laser bias current (%)
Laser Bias (Max)	Maximum percentage of laser bias current (%)
Rx Optical Pwr (Min)	Minimum receive optical power (dBm)
Rx Optical Pwr (Avg)	Average receive optical power (dBm)
Rx Optical Pwr (Max)	Maximum receive optical power (dBm)
Tx Optical Pwr (Min)	Minimum transmit optical power (dBm)
TX Optical Pwr (Avg)	Average transmit optical power (dBm)
Tx Optical Pwr (Max)	Maximum transmit optical power (dBm)

Table 15-71 Near-End or Far-End Section PM Parameters for OC-3, OC-12, and OC-48 Payloads on TXP_MR_2.5G and TXPP_MR_2.5G Cards

Parameter	Definition
CV-S	Section Coding Violation (CV-S) is a count of BIP errors detected at the section-layer (that is, using the B1 byte in the incoming SONET signal). Up to eight section BIP errors can be detected per STS-N frame; each error increments the current CV-S second register.
ES-S	Section Errored Seconds (ES-S) is a count of the number of seconds when at least one section-layer BIP error was detected or an SEF or LOS defect was present.
SES-S	Section Severely Errored Seconds (SES-S) is a count of the seconds when K (see GR-253 for value) or more section-layer BIP errors were detected or an SEF or LOS defect was present.
SEFS-S	Section Severely Errored Framing Seconds (SEFS-S) is a count of the seconds when an SEF defect was present. An SEF defect is expected to be present during most seconds when an LOS or LOF defect is present. However, there may be situations when the SEFS-S parameter is only incremented based on the presence of an SEF defect.

Table 15-72 Near-End or Far-End Line-Layer PM Parameters for OC-3, OC-12, and OC-48 Payloads on TXP_MR_2.5G TXPP_MR_2.5G Cards

Parameter	Definition
CV-L	Line Code Violation (CV-L) is a count of BIP errors detected at the line-layer (that is, using the B2 bytes in the incoming SONET signal). Up to 8 x N BIP errors can be detected per STS-N frame; each error increments the current CV-L second register.
ES-L	Line Errored Seconds (ES-L) is a count of the seconds when at least one line-layer BIP error was detected or an AIS-L defect was present.
SES-L	Line Severely Errored Seconds (SES-L) is a count of the seconds when K (see GR-253 for values) or more line-layer BIP errors were detected or an AIS-L defect was present.
UAS-L	Line Unavailable Seconds (UAS-L) is a count of the seconds when the line is unavailable. A line becomes unavailable when ten consecutive seconds occur that qualify as SES-Ls, and it continues to be unavailable until ten consecutive seconds occur that do not qualify as SES-Ls.
FC-L	Line Failure Count (FC-L) is a count of the number of near-end line failure events. A failure event begins when an AIS-L failure or a lower-layer traffic-related, near-end failure is declared. This failure event ends when the failure is cleared. A failure event that begins in one period and ends in another period is counted only in the period where it begins.

Table 15-73 Near-End or Far-End PM Parameters for Ethernet and Fiber-Channel Payloads on TXP_MR_2.5G and TXPP_MR_2.5G Cards

Parameter	Definition
Valid Packets	A count of received packets that contain non-errored data code groups that have start and end delimiters.
Invalid Packets	A count of received packets that contain errored data code groups that have start and end delimiters.
Code Group Violations	A count of received code groups that do not contain a start or end delimiter.
Idle Ordered Sets	A count of received packets containing idle ordered sets.
Non-Idle Ordered Sets	A count of received packets containing non-idle ordered sets.
Data Code Groups	A count of received data code groups that do not contain ordered sets.

**Note**

ESCON, DV6000, SDI/D1 video, and HDTV client signals are unframed payload data types. If the configured payload data type is unframed, line threshold provisioning and performance monitoring are not available.

Table 15-74 Near-End or Far-End OTN G.709 PM Parameters for TXP_MR_2.5G and TXPP_MR_2.5G Cards

Parameter	Definition
BBE-SM	Section Monitoring Background Block Errors (BBE-SM) indicates the number of background block errors recorded in the OTN section during the PM time interval.
ES-SM	Section Monitoring Errored Seconds (ES-SM) indicates the errored seconds recorded in the OTN section during the PM time interval.
SES-SM	Section Monitoring Severely Errored Seconds (SES-SM) indicates the severely errored seconds recorded in the OTN section during the PM time interval.
UAS-SM	Section Monitoring Unavailable Seconds (UAS-SM) indicates the unavailable seconds recorded in the OTN section during the PM time interval.
FC-SM	Section Monitoring Failure Counts (FC-SM) indicates the failure counts recorded in the OTN section during the PM time interval.
ESR-SM	Section Monitoring Errored Seconds Ratio (ESR-SM) indicates the errored seconds ratio recorded in the OTN section during the PM time interval.
SESR-SM	Section Monitoring Severely Errored Seconds Ratio (SESR-SM) indicates the severely errored seconds ratio recorded in the OTN section during the PM time interval.
BBER-SM	Section Monitoring Background Block Errors Ratio (BBER-SM) indicates the background block errors ratio recorded in the OTN section during the PM time interval.

Table 15-74 Near-End or Far-End OTN G.709 PM Parameters for TXP_MR_2.5G and TXPP_MR_2.5G Cards (continued)

Parameter	Definition
BBE-PM	Path Monitoring Background Block Errors (BBE-PM) indicates the number of background block errors recorded in the OTN path during the PM time interval.
ES-PM	Path Monitoring Errored Seconds (ES-PM) indicates the errored seconds recorded in the OTN path during the PM time interval.
SES-PM	Path Monitoring Severely Errored Seconds (SES-PM) indicates the severely errored seconds recorded in the OTN path during the PM time interval.
UAS-PM	Path Monitoring Unavailable Seconds (UAS-PM) indicates the unavailable seconds recorded in the OTN path during the PM time interval.
FC-PM	Path Monitoring Failure Counts (FC-PM) indicates the failure counts recorded in the OTN path during the PM time interval.
ESR-PM	Path Monitoring Errored Seconds Ratio (ESR-PM) indicates the errored seconds ratio recorded in the OTN path during the PM time interval.
SESR-PM	Path Monitoring Severely Errored Seconds Ratio (SESR-PM) indicates the severely errored seconds ratio recorded in the OTN path during the PM time interval.
BBER-PM	Path Monitoring Background Block Errors Ratio (BBER-PM) indicates the background block errors ratio recorded in the OTN path during the PM time interval.

Table 15-75 Near-End or Far-End OTN FEC PM Parameters for TXP_MR_2.5G and TXPP_MR_2.5G Cards

Parameter	Definition
Bit Errors Corrected	The number of bit errors corrected in the DWDM trunk line during the PM time interval.
Uncorrectable Words	The number of uncorrectable words detected in the DWDM trunk line during the PM time interval.

15.7.6 MXP_2.5G_10G Card Performance Monitoring Parameters

Figure 15-21 on page 15-62 shows the signal types that support near-end and far-end PMs. Figure 15-22 on page 15-62 shows where overhead bytes detected on the ASICs produce performance monitoring parameters for the MXP_2.5G_10G card.

Figure 15-21 Monitored Signal Types for MXP_2.5G_10G Cards

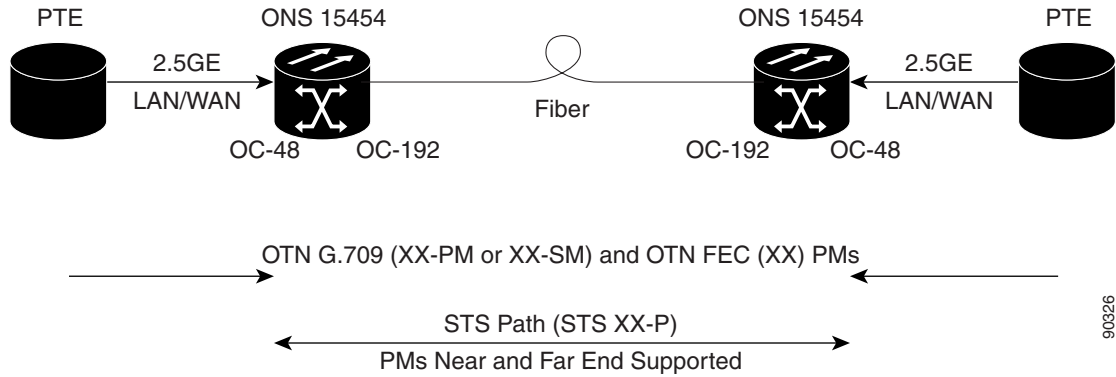

Note

The XX in Figure 15-21 represents all PMs listed in Table 15-76 on page 15-63 through Table 15-80 on page 15-65 with the given prefix and/or suffix.

Figure 15-22 PM Read Points on MXP_2.5G_10G Cards

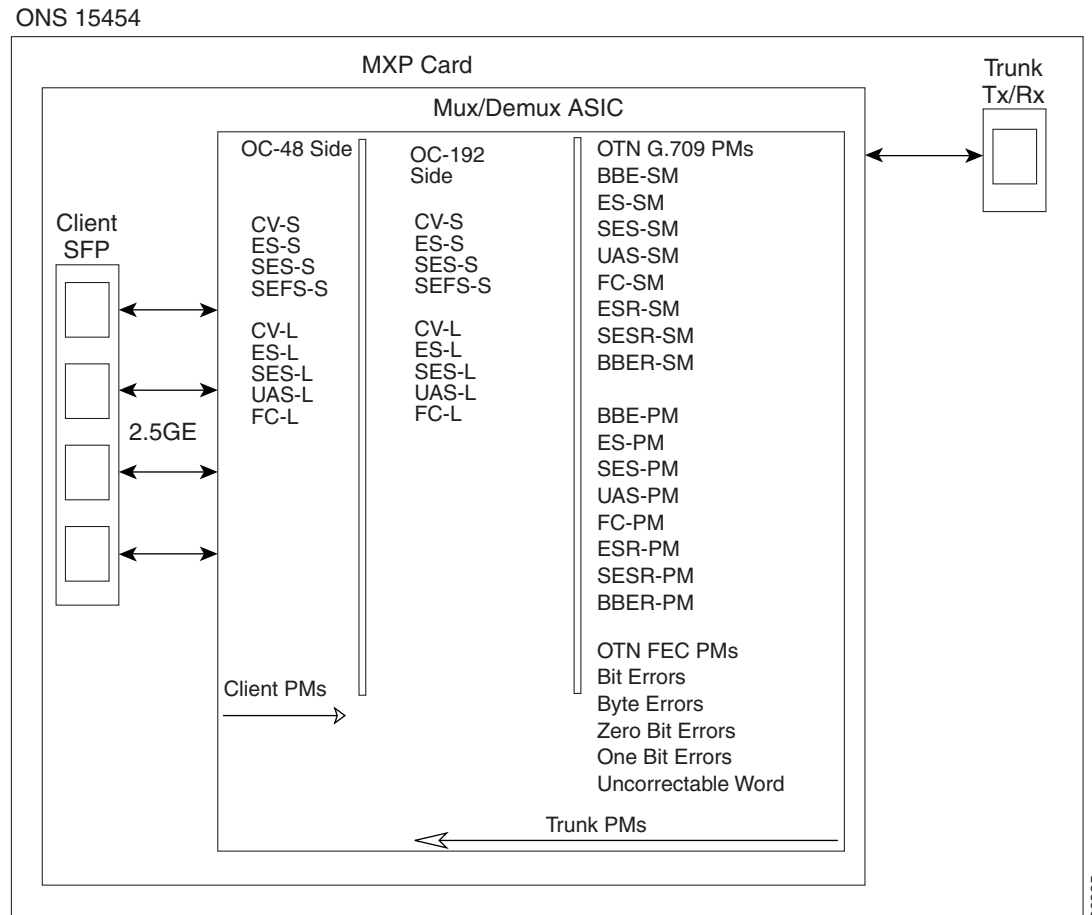

The PM parameters for the MXP_2.5G_10G cards are described in Table 15-76 on page 15-63 through Table 15-80 on page 15-65.

Table 15-76 Physical Optics PM Parameters for MXP_2.5G_10G Cards

Parameter	Definition
Laser Bias (Min)	Minimum percentage of laser bias current (%)
Laser Bias (Avg)	Average percentage of laser bias current (%)
Laser Bias (Max)	Maximum percentage of laser bias current (%)
Rx Optical Pwr (Min)	Minimum receive optical power (dBm)
Rx Optical Pwr (Avg)	Average receive optical power (dBm)
Rx Optical Pwr (Max)	Maximum receive optical power (dBm)
Tx Optical Pwr (Min)	Minimum transmit optical power (dBm)
TX Optical Pwr (Avg)	Average transmit optical power (dBm)
Tx Optical Pwr (Max)	Maximum transmit optical power (dBm)

Table 15-77 Near-End or Far-End Section PM Parameters for MXP_2.5G_10G Cards

Parameter	Definition
CV-S	Section Coding Violation (CV-S) is a count of BIP errors detected at the section-layer (that is, using the B1 byte in the incoming SONET signal). Up to eight section BIP errors can be detected per STS-N frame; each error increments the current CV-S second register.
ES-S	Section Errored Seconds (ES-S) is a count of the number of seconds when at least one section-layer BIP error was detected or an SEF or LOS defect was present.
SES-S	Section Severely Errored Seconds (SES-S) is a count of the seconds when K (see GR-253 for value) or more section-layer BIP errors were detected or an SEF or LOS defect was present.
SEFS-S	Section Severely Errored Framing Seconds (SEFS-S) is a count of the seconds when an SEF defect was present. An SEF defect is expected to be present during most seconds when an LOS or LOF defect is present. However, there may be situations when the SEFS-S parameter is only incremented based on the presence of an SEF defect.

Table 15-78 Near-End or Far-End Line Layer PM Parameters for MXP_2.5G_10G Cards

Parameter	Definition
CV-L	Line Code Violation (CV-L) is a count of BIP errors detected at the line-layer (that is, using the B2 bytes in the incoming SONET signal). Up to 8 x N BIP errors can be detected per STS-N frame; each error increments the current CV-L second register.
ES-L	Line Errored Seconds (ES-L) is a count of the seconds when at least one line-layer BIP error was detected or an AIS-L defect was present.

Table 15-78 Near-End or Far-End Line Layer PM Parameters for MXP_2.5G_10G Cards (continued)

Parameter	Definition
SES-L	Line Severely Errored Seconds (SES-L) is a count of the seconds when K (see GR-253 for values) or more line-layer BIP errors were detected or an AIS-L defect was present.
UAS-L	Line Unavailable Seconds (UAS-L) is a count of the seconds when the line is unavailable. A line becomes unavailable when ten consecutive seconds occur that qualify as SES-Ls, and it continues to be unavailable until ten consecutive seconds occur that do not qualify as SES-Ls.
FC-L	Line Failure Count (FC-L) is a count of the number of near-end line failure events. A failure event begins when an AIS-L failure or a lower-layer traffic-related, near-end failure is declared. This failure event ends when the failure is cleared. A failure event that begins in one period and ends in another period is counted only in the period where it begins.

Table 15-79 Near-End or Far-End OTN G.709 PM Parameters for MXP_2.5G_10G Cards

Parameter	Definition
BBE-SM	Section Monitoring Background Block Errors (BBE-SM) indicates the number of background block errors recorded in the OTN section during the PM time interval.
ES-SM	Section Monitoring Errored Seconds (ES-SM) indicates the errored seconds recorded in the OTN section during the PM time interval.
SES-SM	Section Monitoring Severely Errored Seconds (SES-SM) indicates the severely errored seconds recorded in the OTN section during the PM time interval.
UAS-SM	Section Monitoring Unavailable Seconds (UAS-SM) indicates the unavailable seconds recorded in the OTN section during the PM time interval.
FC-SM	Section Monitoring Failure Counts (FC-SM) indicates the failure counts recorded in the OTN section during the PM time interval.
ESR-SM	Section Monitoring Errored Seconds Ratio (ESR-SM) indicates the errored seconds ratio recorded in the OTN section during the PM time interval.
SESR-SM	Section Monitoring Severely Errored Seconds Ratio (SESR-SM) indicates the severely errored seconds ratio recorded in the OTN section during the PM time interval.
BBER-SM	Section Monitoring Background Block Errors Ratio (BBER-SM) indicates the background block errors ratio recorded in the OTN section during the PM time interval.
BBE-PM	Path Monitoring Background Block Errors (BBE-PM) indicates the number of background block errors recorded in the OTN path during the PM time interval.
ES-PM	Path Monitoring Errored Seconds (ES-PM) indicates the errored seconds recorded in the OTN path during the PM time interval.

Table 15-79 Near-End or Far-End OTN G.709 PM Parameters for MXP_2.5G_10G Cards (continued)

Parameter	Definition
SES-PM	Path Monitoring Severely Errored Seconds (SES-PM) indicates the severely errored seconds recorded in the OTN path during the PM time interval.
UAS-PM	Path Monitoring Unavailable Seconds (UAS-PM) indicates the unavailable seconds recorded in the OTN path during the PM time interval.
FC-PM	Path Monitoring Failure Counts (FC-PM) indicates the failure counts recorded in the OTN path during the PM time interval.
ESR-PM	Path Monitoring Errored Seconds Ratio (ESR-PM) indicates the errored seconds ratio recorded in the OTN path during the PM time interval.
SESR-PM	Path Monitoring Severely Errored Seconds Ratio (SESR-PM) indicates the severely errored seconds ratio recorded in the OTN path during the PM time interval.
BBER-PM	Path Monitoring Background Block Errors Ratio (BBER-PM) indicates the background block errors ratio recorded in the OTN path during the PM time interval.

Table 15-80 Near-End or Far-End OTN FEC PM Parameters for MXP_2.5G_10G Cards

Parameter	Definition
Bit Errors Corrected	The number of bit errors corrected in the DWDM trunk line during the PM time interval.
Uncorrectable Words	The number of uncorrectable words detected in the DWDM trunk line during the PM time interval.

15.8 Performance Monitoring for DWDM Cards

The following sections define performance monitoring parameters and definitions for the OPT-PRE, OPT-BST, 32 MUX-O, 32 DMX-O, 4MD-xx.x, AD-1C-xx.x, AD-2C-xx.x, AD-4C-xx.x, AD-1B-xx.x, AD-4B-xx.x, OSCM, and OSC-CSM DWDM cards.

15.8.1 Optical Amplifier Card Performance Monitoring Parameters

The PM parameters for the OPT-PRE and OPT-BST cards are described in Table 15-81 and Table 15-82 on page 15-66.

Table 15-81 Optical Line PM Parameters for OPT-PRE and OPT-BST Cards

Parameter	Definition
Optical Pwr (Min)	Minimum received optical power (dBm)
Optical Pwr (Avg)	Average received optical power (dBm)
Optical Pwr (Max)	Maximum received optical power (dBm)

Table 15-82 Optical Amplifier Line PM Parameters for OPT-PRE and OPT-BST Cards

Parameter	Definition
Optical Pwr (Min)	Minimum transmit optical power (dBm)
Optical Pwr (Avg)	Average transmit optical power (dBm)
Optical Pwr (Max)	Maximum transmit optical power (dBm)

15.8.2 Multiplexer and Demultiplexer Card Performance Monitoring Parameters

The PM parameters for the 32 MUX-O and 32 DMX-O cards are described in Table 15-83 and Table 15-84.

Table 15-83 Optical Channel PMs for 32 MUX-O and 32 DMX-O Cards

Parameter	Definition
Optical Pwr (Min)	Minimum receive optical power (dBm)
Optical Pwr (Avg)	Average receive optical power (dBm)
Optical Pwr (Max)	Maximum receive optical power (dBm)

Table 15-84 Optical Line PMs for 32 MUX-O and 32 DMX-O Cards

Parameter	Definition
Optical Pwr (Min)	Minimum transmit optical power (dBm)
Optical Pwr (Avg)	Average transmit optical power (dBm)
Optical Pwr (Max)	Maximum transmit optical power (dBm)

15.8.3 4MD-xx.x Card Performance Monitoring Parameters

The PM parameters for the 4MD-xx.x cards are described in Table 15-85 and Table 15-86 on page 15-67.

Table 15-85 Optical Channel PMs for 4MD-xx.x Cards

Parameter	Definition
Optical Pwr (Min)	Minimum receive optical power (dBm)
Optical Pwr (Avg)	Average receive optical power (dBm)
Optical Pwr (Max)	Maximum receive optical power (dBm)

Table 15-86 Optical Band PMs for 4MD-xx.x Cards

Parameter	Definition
Optical Pwr (Min)	Minimum transmit optical power (dBm)
Optical Pwr (Avg)	Average transmit optical power (dBm)
Optical Pwr (Max)	Maximum transmit optical power (dBm)

15.8.4 OADM Channel Filter Card Performance Monitoring Parameters

The PM parameters for the AD-1C-xx.x, AD-2C-xx.x, and AD-4C-xx.x cards are described in Table 15-87 and Table 15-88.

Table 15-87 Optical Channel PMs for AD-1C-xx.x, AD-2C-xx.x, and AD-4C-xx.x Cards

Parameter	Definition
Optical Pwr (Min)	Minimum receive optical power (dBm)
Optical Pwr (Avg)	Average receive optical power (dBm)
Optical Pwr (Max)	Maximum receive optical power (dBm)

Table 15-88 Optical Line PMs for AD-1C-xx.x, AD-2C-xx.x, and AD-4C-xx.x Cards

Parameter	Definition
Optical Pwr (Min)	Minimum transmit optical power (dBm)
Optical Pwr (Avg)	Average transmit optical power (dBm)
Optical Pwr (Max)	Maximum transmit optical power (dBm)

15.8.5 OADM Band Filter Card Performance Monitoring Parameters

The PM parameters for the AD-1B-xx.x and AD-4B-xx.x cards are described in Table 15-89 and Table 15-90 on page 15-68.

Table 15-89 Optical Line PMs for AD-1B-xx.x and AD-4B-xx.x Cards

Parameter	Definition
Optical Pwr (Min)	Minimum receive optical power (dBm)
Optical Pwr (Avg)	Average receive optical power (dBm)
Optical Pwr (Max)	Maximum receive optical power (dBm)

Table 15-90 Optical Band PMs for AD-1B-xx.x and AD-4B-xx.x Cards

Parameter	Definition
Optical Pwr (Min)	Minimum transmit optical power (dBm)
Optical Pwr (Avg)	Average transmit optical power (dBm)
Optical Pwr (Max)	Maximum transmit optical power (dBm)

15.8.6 Optical Service Channel Card Performance Monitoring Parameters

Figure 15-23 shows where overhead bytes detected on the ASICs produce performance monitoring parameters for the OSCM and OSC-CSM cards.

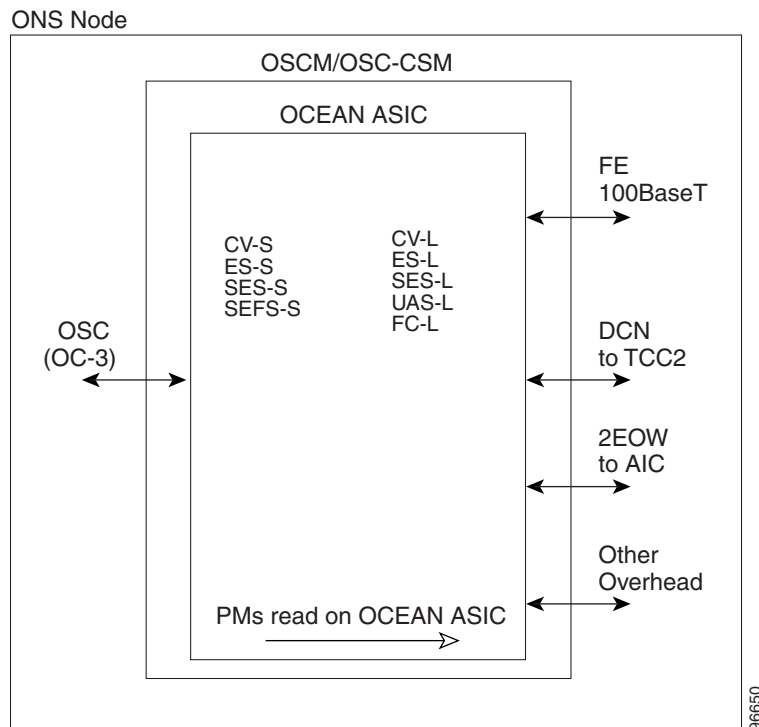
Figure 15-23 PM Read Points on OSCM and OSC-CSM Cards

The PM parameters for the OSCM and OSC-CSM cards are described in Table 15-91 through Table 15-95 on page 15-70.

Table 15-91 Optical Line PMs for OSCM and OSC-CSM Cards

Parameter	Definition
Optical Pwr (Min)	Minimum transmit optical power (dBm)
Optical Pwr (Avg)	Average transmit optical power (dBm)
Optical Pwr (Max)	Maximum transmit optical power (dBm)

Table 15-92 Near-End or Far-End Section PM Parameters for OSCM and OSC-CSM Cards

Parameter	Definition
CV-S	Section Coding Violation (CV-S) is a count of BIP errors detected at the section-layer (that is, using the B1 byte in the incoming SONET signal). Up to eight section BIP errors can be detected per STS-N frame; each error increments the current CV-S second register.
ES-S	Section Errored Seconds (ES-S) is a count of the number of seconds when at least one section-layer BIP error was detected or an SEF or LOS defect was present.
SES-S	Section Severely Errored Seconds (SES-S) is a count of the seconds when K (see GR-253 for value) or more section-layer BIP errors were detected or an SEF or LOS defect was present.
SEFS-S	Section Severely Errored Framing Seconds (SEFS-S) is a count of the seconds when an SEF defect was present. An SEF defect is expected to be present during most seconds when an LOS or LOF defect is present. However, there may be situations when the SEFS-S parameter is only incremented based on the presence of an SEF defect.

Table 15-93 Near-End or Far-End Line Layer PM Parameters for OSCM and OSC-CSM Cards

Parameter	Definition
CV-L	Near-End Line Code Violation (CV-L) is a count of BIP errors detected at the line-layer (that is, using the B2 bytes in the incoming SONET signal). Up to 8 x N BIP errors can be detected per STS-N frame; each error increments the current CV-L second register.
ES-L	Near-End Line Errored Seconds (ES-L) is a count of the seconds when at least one line-layer BIP error was detected or an AIS-L defect was present.
SES-L	Near-End Line Severely Errored Seconds (SES-L) is a count of the seconds when K (see GR-253 for values) or more line-layer BIP errors were detected or an AIS-L defect was present.
UAS-L	Near-End Line Unavailable Seconds (UAS-L) is a count of the seconds when the line is unavailable. A line becomes unavailable when ten consecutive seconds occur that qualify as SES-Ls, and it continues to be unavailable until ten consecutive seconds occur that do not qualify as SES-Ls.
FC-L	Near-End Line Failure Count (FC-L) is a count of the number of near-end line failure events. A failure event begins when an AIS-L failure or a lower-layer traffic-related, near-end failure is declared. This failure event ends when the failure is cleared. A failure event that begins in one period and ends in another period is counted only in the period where it begins.

**Note**

On CTC, the count fields for PPJC and NPJC PM parameters appear white and blank unless they are enabled on the Provisioning > OC3 Line tabs. See the “Pointer Justification Count Performance Monitoring” section on page 3.

Table 15-94 Near-End Pointer Justification PM Parameters for OSCM and OSC-CSM Cards

Parameter	Definition
PPJC-Pdet	Positive Pointer Justification Count, STS Path Detected (PPJC-Pdet) is a count of the positive pointer justifications detected on a particular path on an incoming SONET signal.
NPJC-Pdet	Negative Pointer Justification Count, STS Path Detected (NPJC-Pdet) is a count of the negative pointer justifications detected on a particular path on an incoming SONET signal.
PPJC-Pgen	Positive Pointer Justification Count, STS Path Generated (PPJC-Pgen) is a count of the positive pointer justifications generated for a particular path to reconcile the frequency of the SPE with the local clock.
NPJC-Pgen	Negative Pointer Justification Count, STS Path Generated (NPJC-Pgen) is a count of the negative pointer justifications generated for a particular path to reconcile the frequency of the synchronous payload envelope (SPE) with the local clock.

**Note**

For information about Troubleshooting Path Protection switch counts, refer to the alarm troubleshooting information in the *Cisco ONS 15454 Troubleshooting Guide*.

Table 15-95 Near-End Protection Switch PM Parameters for OSCM and OSC-CSM Cards

Parameter	Definition
PSC (BLSR)	For a protect line in a two-fiber ring, Protection Switching Count (PSC) refers to the number of times a protection switch has occurred either to a particular span's line protection or away from a particular span's line protection. Therefore, if a protection switch occurs on a two-fiber BLSR, the PSC of the protection span to which the traffic is switched increments, and when the switched traffic returns to its original working span from the protect span, the PSC of the protect span increments again.
PSC (1+1 protection)	In a 1 + 1 protection scheme for a working card, Protection Switching Count (PSC) is a count of the number of times service switches from a working card to a protection card plus the number of times service switches back to the working card. For a protection card, PSC is a count of the number of times service switches to a working card from a protection card plus the number of times service switches back to the protection card. The PSC PM is only applicable if revertive line-level protection switching is used.
PSD	Protection Switching Duration (PSD) applies to the length of time, in seconds, that service is carried on another line. For a working line, PSD is a count of the number of seconds that service was carried on the protection line. For the protection line, PSD is a count of the seconds that the line was used to carry service. The PSD PM is only applicable if revertive line-level protection switching is used.

Table 15-95 Near-End Protection Switch PM Parameters for OSCM and OSC-CSM Cards (continued)

Parameter	Definition
PSC-W	<p>For a working line in a two-fiber BLSR, Protection Switching Count-Working (PSC-W) is a count of the number of times traffic switches away from the working capacity in the failed line and back to the working capacity after the failure is cleared. PSC-W increments on the failed working line and PSC increments on the active protect line.</p> <p>For a working line in a four-fiber BLSR, PSC-W is a count of the number of times service switches from a working line to a protection line plus the number of times it switches back to the working line. PSC-W increments on the failed line and PSC-R or PSC-S increments on the active protect line.</p>
PSD-W	For a working line in a two-fiber BLSR, Protection Switching Duration-Working (PSD-W) is a count of the number of seconds that service was carried on the protection line. PSD-W increments on the failed working line and PSD increments on the active protect line.
PSC-S	In a four-fiber BLSR, Protection Switching Count-Span (PSC-S) is a count of the number of times service switches from a working line to a protection line plus the number of times it switches back to the working line. A count is only incremented if span switching is used.
PSD-S	In a four-fiber BLSR, Protection Switching Duration-Span (PSD-S) is a count of the seconds that the protection line was used to carry service. A count is only incremented if span switching is used.
PSC-R	In a four-fiber BLSR, Protection Switching Count-Ring (PSC-R) is a count of the number of times service switches from a working line to a protection line plus the number of times it switches back to a working line. A count is only incremented if ring switching is used.
PSD-R	In a four-fiber BLSR, Protection Switching Duration-Ring (PSD-R) is a count of the seconds that the protection line was used to carry service. A count is only incremented if ring switching is used.

