



Connecting the ICIM to Multiple Prisma II Chassis Installation Instructions

Overview

Audience

These installation instructions are intended for all cable system operators or installers of the Prisma II™ Chassis using the ICIM or Transmission Network Control System (TNCS) software.

Introduction

The Prisma II Chassis transports communication and control signals from the application modules to the ICIM, LCI interface, or TNCS software. These installation instructions are intended as a quick guide to the connecting these components.

ICIM Location

If an ICIM is installed in the Prisma II Chassis, it must be installed in slots 15/16.

Additional Information

For additional information, refer to the guide that was shipped with the chassis, *Prisma II Chassis Installation and Operation Guide*, part number 713375.

Communication Connections

Chassis-to-Chassis ICIM Connections

The Prisma II platform allows the ICIM to be located in one chassis and control application modules located in several other chassis. This communication “daisy-chain” can be enabled by connecting cables to the **ICIM IN** and **ICIM OUT** connectors located on the connector interface panel of the chassis. This connection is required if an ICIM in one chassis is to communicate with or control any application module located in a separate chassis.

Note: An ICIM can control a maximum of 140 modules. Depending on your application, this is typically 6 or 7 chassis to a rack. Do not exceed these limits.

ICIM IN and ICIM OUT Connectors

Every Prisma II Chassis has a DB9 **ICIM IN** and an DB9 **ICIM OUT** connector for the purpose of chassis-to-chassis ICIM connections. **ICIM OUT** is a male connector and **ICIM IN** is a female connector.



ICIM IN and ICIM OUT Cables

The cable required for both **ICIM IN** and **ICIM OUT** connections is a standard “off the shelf” serial extension cable, DB9 Female to DB9 Male. This cable can be purchased at your local computer store or from Scientific-Atlanta.

The Scientific-Atlanta part number for a 6-foot DB9 Female to DB9 Male serial extension cable is 180143. The connectors are a Serial - 9 pin D-shell (EIA 574/232).

ICIM IN and ICIM OUT Cable Connection Procedure

To make chassis-to-chassis **ICIM IN** and **ICIM OUT** connections, follow these steps.

1. Connect the serial extension cable from the **ICIM OUT** of the chassis containing the ICIM to the **ICIM IN** connector of the second chassis.
2. Connect a serial extension cable from the **ICIM OUT** of the second chassis to the **ICIM IN** of the third chassis.
3. Continue this “daisy-chain” connection until all desired chassis are connected.

Notes:

- All chassis connected in this “daisy-chain” must be powered and have a fan tray installed. A chassis that is connected but is either not powered, or does not have a fan tray installed, will cause faulty operation of the ICIM.
- All chassis connected in this “daisy-chain” must have a unique chassis ID number.

Continued on next page

Communication Connections, Continued

Connecting a Prisma II Chassis to the TNCS Server Using the EM Connectors

Connecting the Prisma II Chassis to the TNCS server requires two special cable kits that are available from Scientific-Atlanta.

- The RS-485 Cable Kit, part number 735748, includes the following:
 - 4 ea. Breakout boxes
 - 4 ea. RS-485 cable assemblies (50')
 - 4 ea. Breakout box mounting brackets
 - 100 ea. 6-32 screws (1.25")
- The Prisma II Cable Kit, part number 738686, includes the following:
 - 4 ea. Prisma II cable assemblies

The RS-485 Cable Kit is used to communicate with the RS-485/422/TTL devices.

EM IN to TNCS Connection

To connect TNCS to a Prisma II Chassis, follow these steps.

1. Mount one of the breakout boxes (included in the RS-485 Cable Kit) in a rack location central to the appropriate Prisma II Chassis.



2. Connect a RS-485 cable assembly (included in the RS-485 Cable Kit) from the breakout box to the **RS-485 COM** port on the TNCS server.
3. Connect one Prisma II Cable Assembly (included in the Prisma II Cable Kit) from the breakout box to the **EM IN** port of each Prisma II Chassis containing an ICIM.

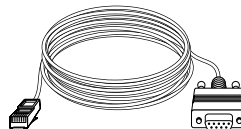

Note: As a general rule, it is recommended that the total number of ICIMs connected to any single COM port on the TNCS server be limited to four (4). However, you may connect more than four ICIMs per TNCS COM port as long as the total number of devices (modules) monitored by a single COM port does not exceed 400 *and* the total number of devices monitored by any single ICIM does not exceed 140.

Continued on next page

Communication Connections, Continued

Using TNCS with Multiple Prisma II Chassis

All chassis within an ICIM's domain are connected in series via the ICIM IN/OUT connectors using standard "off the shelf" serial extension cable, DB9 Female to DB9 Male. Using the EM IN/OUT connectors, a chassis with an ICIM installed is connected to a breakout box as shown below. The breakout box is connected to the TNCS server with the cable included in the RS-485 Cable Kit.

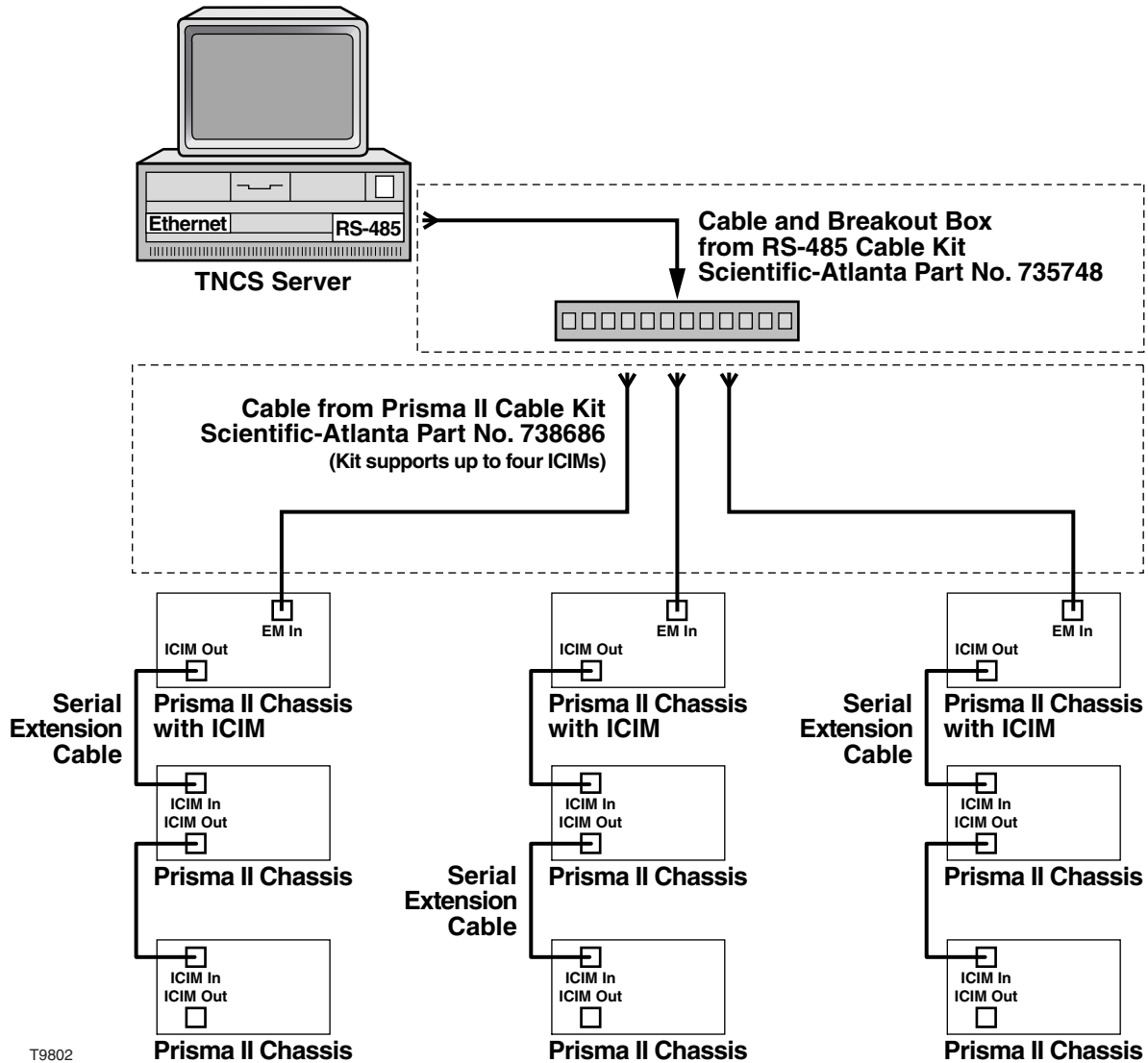

T9802

The Front Access Chassis

Overview

The Prisma II Chassis may be factory configured for front access in order to accommodate back-to-back installations, remote terminal (RT) installations, or other space limitations.

Prisma II Front Access Chassis

The illustration below shows the front view of the front access Prisma II Chassis with power supplies, modules, and the ICIM installed. The connector interface panel, which houses the I/O connectors and power inlets, is located on the recessed bottom of the front panel on the front access version of the chassis.

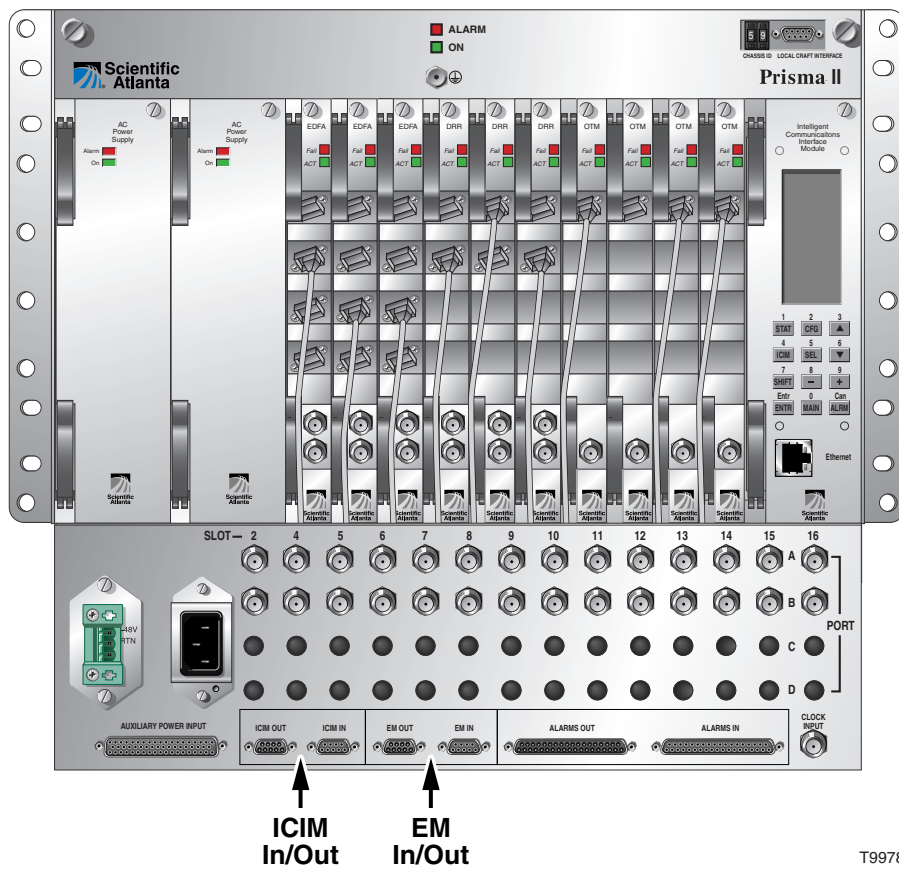

T9978

The Rear Access Chassis

Prisma II Rear Access Chassis

The illustration below shows the front view of the rear access Prisma II Chassis with power supplies, modules, and the ICIM installed.

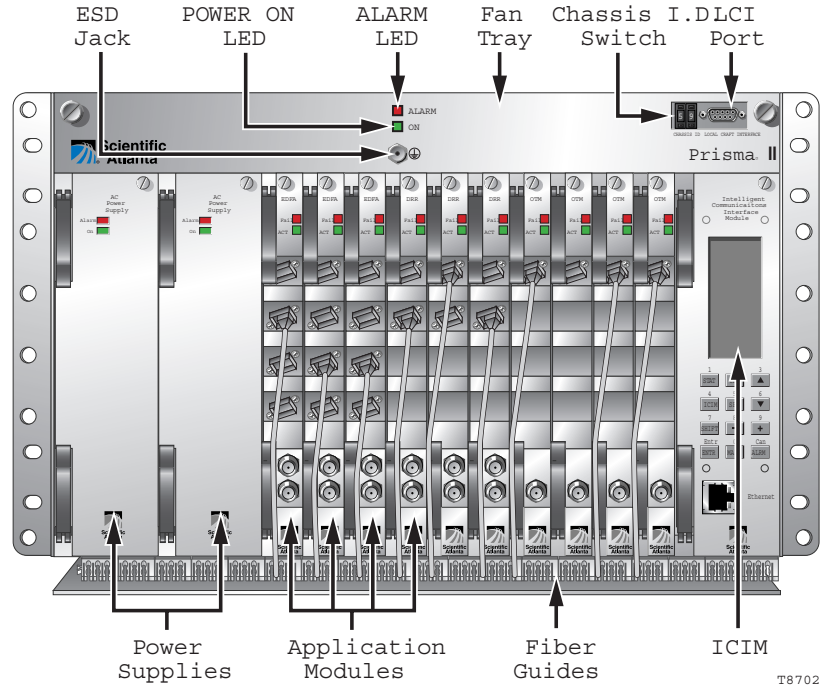

Connector Interface Panel on the Rear Access Chassis

The connector interface panel, which houses the I/O connectors and power inlets, is located on the back on the rear access version of the chassis.

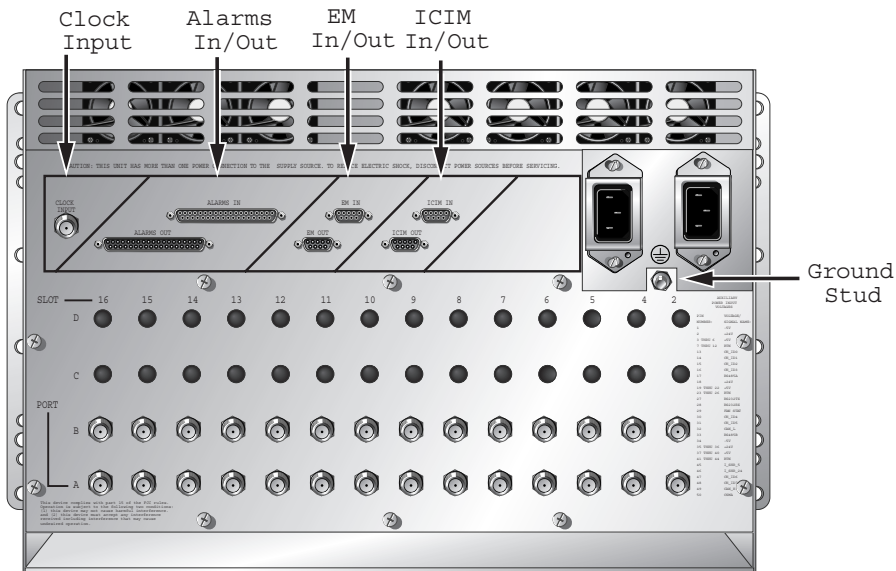

For Information

If You Have Questions

This table lists the Technical Support and Customer Service numbers for your area.

Region	Centers	Telephone and Fax Numbers
North America	SciCare™ Services Atlanta, Georgia United States	For <i>Technical Support</i> , call: <ul style="list-style-type: none"> ■ Toll-free: 1-800-722-2009 ■ Local: 678-277-1120 (Press 2 at the prompt) For <i>Customer Service</i> or to request an RMA number, call: <ul style="list-style-type: none"> ■ Toll-free: 1-800-722-2009 ■ Local: 678-277-1120 (Press 3 at the prompt) ■ Fax: 770-236-5477 ■ E-mail: customer.service@sciatl.com
Europe, Middle East, Africa	Belgium	For <i>Technical Support</i> , call: <ul style="list-style-type: none"> ■ Telephone: 32-56-445-197 or 32-56-445-155 ■ Fax: 32-56-445-053 For <i>Customer Service</i> or to request an RMA number, call: <ul style="list-style-type: none"> ■ Telephone: 32-56-445-133 or 32-56-445-118 ■ Fax: 32-56-445-051 ■ E-mail: elc.service@sciatl.com
Japan	Japan	<ul style="list-style-type: none"> ■ Telephone: 81-3-5908-2153 or +81-3-5908-2154 ■ Fax: 81-3-5908-2155 ■ E-mail: yuri.oguchi@sciatl.com
Korea	Korea	<ul style="list-style-type: none"> ■ Telephone: 82-2-3429-8800 ■ Fax: 82-2-3452-9748 ■ E-mail: kelly.song@sciatl.com
China (mainland)	China	<ul style="list-style-type: none"> ■ Telephone: 86-21-6485-3205 ■ Fax: 86-21-6485-3205 ■ E-mail: xiangyang.shan@sciatl.com
All other Asia-Pacific countries & Australia	Hong Kong	<ul style="list-style-type: none"> ■ Telephone: 852-2588-4746 ■ Fax: 852-2588-3139 ■ E-mail: support.apr@sciatl.com
Brazil	Brazil	For <i>Technical Support</i> , call: <ul style="list-style-type: none"> ■ Telephone: 55-11-3845-9154 ext 230 ■ Fax: 55-11-3845-2514 For <i>Customer Service</i> or to request an RMA number, call: <ul style="list-style-type: none"> ■ Telephone: 55-11-3845-9154, ext 109 ■ Fax: 55-11-3845-2514 ■ E-mail: luiz.fattinger@sciatl.com
Mexico, Central America, Caribbean	Mexico	For <i>Technical Support</i> , call: <ul style="list-style-type: none"> ■ Telephone: 52-3515152599 ■ Fax: 52-3515152599 For <i>Customer Service</i> or to request an RMA number, call: <ul style="list-style-type: none"> ■ Telephone: 52-55-50-81-8425 ■ Fax: 52-55-52-61-0893 ■ E-mail: karla.lugo@sciatl.com
All other Latin America countries	Argentina	For <i>Technical Support</i> , call: <ul style="list-style-type: none"> ■ Telephone: 54-23-20-403340 ext 109 ■ Fax: 54-23-20-403340 ext 103 For <i>Customer Service</i> or to request an RMA number, call: <ul style="list-style-type: none"> ■ Telephone: 770-236-5662 ■ Fax: 770-236-5888 ■ E-mail: veda.keillor@sciatl.com



Scientific Atlanta, A Cisco Company
5030 Sugarloaf Parkway, Box 465447
Lawrenceville, GA 30042

678.277.1000
www.scientificatlanta.com

Cisco, Cisco Systems, the Cisco logo, the Cisco Systems logo, Scientific Atlanta, Prisma, Prisma II, and SciCare are registered trademarks or trademarks of Cisco Systems, Inc. and/or its affiliates in the U.S. and certain other countries.

All other trademarks mentioned in this document are the property of their respective owners.

Product and service availability are subject to change without notice.

© 2000, 2008 Cisco Systems, Inc. All rights reserved.
August 2008

Printed in United States of America
Part Number 741983 Rev C